

NEC



Installation Manual

NEC Business Solutions Ltd

A6-506000-642-01(8508)

Release 6.0

November 2003

This page is intentionally blank.

Table of Contents

Chapter 1

System Overview

Section 1	Your System	19
Section 2	Regulatory Information	21
	Electromagnetic Interference (EMI)	21
	Battery Disposal	21
	Incidence of Harm	21
	Hearing Aid Compatibility	21
	Service Requirements	21
	Compliance Information	21
Section 3	Equipment	22
Section 4	System Capacities	27
Section 5	System Block Diagram	28
Section 6	Cabling Requirements & Specifications	29
Section 7	Power Requirements	31
	Power Supply Inputs	31
	Power Supply Consumption	31
Section 8	Environmental conditions	31
	Temperature	31
	Humidity	31
Section 9	Weights & Dimensions	32
Section 10	Outside Line Type	33
Section 11	Network & Control	33
	Transmission, Network & Control Specifications	33
	Telephone	34
Section 12	Dialling Specifications	35
	Dial Pulse Address Signalling	35
	Dual-Tone Multifrequency (DTMF) Address Signalling	35
Section 13	External Equipment Connection	36

Section 14	Battery Backup	37
	System Backup	37
	Memory Backup	37
Section 15	Visual & Audible Indications	38
	Tone Patterns Table	38
	Multiline Terminal Flash Patterns Table	41
	DSS/BLF LED Indications Table	42

Chapter 2

KSU Installation

Section 1	General Information	43
Section 2	Site Preparation	43
	Precautionary Information	43
	Site Selection Conditions	44
	Multiline Telephone Installation Site	45
Section 3	Installing the Key Service Unit (KSU)	45
	Installation Precautions	45
	The Key Service Unit	45
	Removing the KSU Cover	46
	Wall Mounting the KSU	47
	Installing or Replacing the Internal Backup Batteries	48
	Connecting External Backup Batteries	50
	Grounding Requirements	52
	Connecting the B614-B13 KSU	52
	Switch Settings	52
	Telephone Connections	54
	Exchange Line Connection	54
	Power Fail Telephone and Fax Connection	54
	External Ringer and External Paging Control Connection	55
	External Speaker Connection	55
	External Music-On-Hold (MOH)/Background Music (BGM) Source Connection	57
	External ROM Card	58
Section 4	Installing an Electronic Telephone Unit (ETU)	60
	General Information	60
	Interface ETUs	61
	SLI(2)-B13 ETU	62
	COI(2)-B13 ETU	63
	CID(2)-B13 Unit	64
	BRT(1)-B13 ETU	66
	Optional ETUs	67
	MIF-B13 ETU	68
	DPH-B13 ETU	70

	Door Phones	71
	Door Lock Release	71
	TRF-B13 ETU	72
	Trunk Transfer Speech Volume Adjustment	72
	VRS-B13 ETU	74
	VMS(2)-B13 ETU	75
	Power Failure Backup	76
	Operation When Input Power is Restored	77
Section 5	Cable Connections	77
	General Information	77
	Wiring to the KSU	79
	Multiline Telephone Connection (Dterm Series i)	79
	Single Line Telephone Connection	80
	Outside Lines	80

Chapter 3

Installing DTB-Type Multiline Terminals

Section 1	General Information	83
Section 2	Multiline Terminals	83
	DTB-16-1A (WH) TEL	83
	DTB-16D-1A (WH) TEL	84
Section 3	Wall Mounting	85
	Wall Mounting Template	88

Chapter 4

Installing Dterm Series i Multiline Terminals

Section 1	General Information	89
Section 2	Multiline Terminals	89
	DTR-2DT-1A() TEL	89
	DTR-8D-1A() TEL	90
	DTR-16D-1A() TEL	90
	DTR-32D-1A() TEL	91
Section 3	Connecting a Dterm Series i Multiline Terminal	92
Section 4	Adjusting the LCD on a Multiline Terminal	93
Section 5	Installing Line Cards and Plastic Panels	94
	Installing the Line Card and Plastic Panel	94
	Removing the Plastic Panel	95

Section 6	Installing a Directory Card on a Multiline Terminal	96
Section 7	Installing a Button Set on a Multiline Terminal	97
Section 8	Adjusting the Height on a Multiline Terminal	98
Section 9	Removing or Installing the Base Plate on a Multiline Terminal	99
	Removing the Base Plate	99
	Installing the Base Plate	99
Section 10	Wall Mounting Multiline Terminals	100
	Wall Mounting a Multiline Terminal using the Base Plate	100
	Removing the Wall Mounted Telephone from the Base Plate	103
	Wall Mounting a Multiline Terminal using the Wall Mount Unit (WM-R() Unit)	105

Chapter 5

Installing Dterm Series i Optional Equipment

Section 1	General Information	109
Section 2	Preparing for Adapter Installation	109
Section 3	Installing Adapters	111
	ACA-U() Unit (AC Adapter)	111
	AD(A)-R() Unit (Ancillary Device Adapter)	112
	AP(A)-R() Unit and AP(R)-R() Unit (Port Adapters)	120
	CT(U)-R() Unit (Computer Telephony Adapter)	123

Chapter 6

Installing DTU-Type Multiline Terminals

Section 1	General Information	127
Section 2	Multiline Terminals	127
	DTU-8-1A (WH) TEL	127
	DTU-8D-1A (WH)/(BK) TEL	128
	DTU-16D-1A (WH)/(BK) TEL	128
	DTU-32D-1A (WH)/(BK) TEL	129
Section 3	Connecting A Multiline Terminal To The System	129
Section 4	Adjusting The LCD	130

Section 5	Installing Line Cards & Plastic Panels	131
	Line Card and Plastic Panel Installation	131
Section 6	Removing Softkeys	132
Section 7	Adjusting The Height Of The Multiline Terminal	133
Section 8	Wall Mounting	134
	Removing and Remounting the Handset Hanger	134
	Wall Mounting, Using the Base Unit	134
	Installing the Wall Mount Unit & Mounting the Multiline Terminal Using the WMU-UA Unit	138
	Removing the Multiline Terminal from the Base Cover	141
	Removing the Multiline Terminal from the WMU-UA Unit	141
Section 9	Installing Optional Adapters	142
	Preparing Multiline Terminal for Adapter Installation	142
	ACA-UA Unit (AC Adapter)	145
	ADA-UA Unit (Ancillary Device Adapter)	146
	Connecting Cables to the ADA-UA Unit	147
	Switch Settings	149
	APR-UA Unit (Analogue Port Ringer)	151
	Installing an APR-UA Unit on a Multiline Terminal	151
	Switch Settings	152
	Connecting Cables on the APR-UA Unit	153
	CTA-BA Unit (Computer Telephony Application)	154
	Installing the CTA-BA Unit	154
	Connecting the Cables on the CTA-BA Unit	155
	Installing the Driver on the PC	155
	HFU-UA (WH) Unit (Handsfree Unit)	156
	Installing an HFU-UA (WH) Unit on a Multiline Terminal	156
	Installing the External Microphone	156
	Switch Settings	157

Chapter 7

Installing ETW-Type Multiline Terminals

Section 1	General Information	159
Section 2	ETW-Type Multiline Terminals	159
Section 3	Connecting an ETW-Type Multiline Terminal	160
	Terminal Update	160
	Modular Terminal Connections	160
	Attach a Multiline Terminal to the System	160

Chapter 8

Installing Optional Terminal Equipment

Section 1	SLT(1)-U13 ADP (Single Line Telephone Adaptor)	161
	Connecting the SLT(1)-U13 ADP to the System	161
	Wall Mounting the SLT(1)-U13 ADP	162

Chapter 9

Telephone Programming

Section 1	Introduction.	165
Section 2	Entering Programming Mode	165
	Programming Guidelines	166
Section 3	Programming Functions	168
Section 4	Programming Functions	169
	Trunk Programming	184
	Telephone Port Programming	188
	Trunk Telephone Menu Programming	194
	Tenant Programming	199
	System Mode Programming	200
	Maintenance Modes	201

List of Figures

Xen Alpha

Release 6.0

Chapter 1

System Overview

Figure 1-1:	System Configuration Sample.	20
Figure 1-2:	NEC Xen Alpha System Block Diagram	28
Figure 1-3:	Connecting the ESI to the Multiline Telephone Using Twisted 2-Pair Cable	29

Chapter 2

KSU Installation

Figure 2-1:	Front View of a KSU	45
Figure 2-2:	How to Remove the KSU Cover	46
Figure 2-3:	Attaching the Wall Mounting Bracket for the KSU to the Wall.	47
Figure 2-4:	Attaching the KSU to the Wall Mount Template	47
Figure 2-5:	Securing the KSU to the Wall Mount Template.	48
Figure 2-6:	Inserting a New Battery in the KSU Unit.	48
Figure 2-7:	Attaching the Battery Connectors	49
Figure 2-8:	Mounting the External Battery Cabinet	51
Figure 2-9:	Connecting External Batteries.	51
Figure 2-10:	KSU Grounding.	52
Figure 2-11:	KSU Switch Settings	53
Figure 2-12:	Telephone Connection	54
Figure 2-13:	Exchange Line Connection	54
Figure 2-14:	Power Fail Telephone and Fax Connection	55
Figure 2-15:	External Ringer Connection	55
Figure 2-16:	External Paging Connection	56
Figure 2-17:	MOH/BGM Source Connection.	57
Figure 2-18:	External ROM Card.	58
Figure 2-19:	Inserting the External ROM Card	59
Figure 2-20:	Installing a Vertically Mounted ETU	60
Figure 2-21:	ESI(8)-B13 ETU	61
Figure 2-22:	SLI(2)-B13 ETU	62
Figure 2-23:	COI(2)-B13 ETU	63
Figure 2-24:	Mounting the CID(2)-B13 Unit onto the Mainboard.	64
Figure 2-25:	Mounting the CID(2)-B13 Unit onto the COI(2)-B13 ETU	65
Figure 2-26:	BRT(1)-B13 ETU.	66
Figure 2-27:	BRT(1)-B13 ETU Connection Cable.	66
Figure 2-28:	PBR-B13 ETU.	67

Figure 2-29:	Removing the Ground Plate	68
Figure 2-30:	Mounting the DB-9 Plate	68
Figure 2-31:	Connecting the DB-9 Cable	69
Figure 2-32:	MIF-B13 ETU	69
Figure 2-33:	DHP-B13 ETU	70
Figure 2-34:	TRF-B13 ETU	72
Figure 2-35:	VRS-B13 ETU	74
Figure 2-36:	VMS(2)-B13 ETU	75
Figure 2-37:	Power Failure Backup Flowchart	76
Figure 2-38:	Attaching the Cables to the Connector	78
Figure 2-39:	Holding the Connector with the Pliers	78
Figure 2-40:	ETW/DTU-Type Multiline Terminal and SLT Adapter Connection . .	79
Figure 2-41:	Dterm Series i Multiline Terminal Connection	79
Figure 2-42:	Single Line Telephone Connection	80
Figure 2-43:	KSU Cabling Knockouts	80
Figure 2-44:	Removing the Knockout Panels in the KSU	81

Chapter 3

Installing DTB-Type Multiline Terminals

Figure 3-1:	DTB-16-1A (WH) TEL Multiline Telephone	83
Figure 3-2:	DTB-16D-1A (WH) TEL Multiline Telephone	84

Chapter 4

Installing Dterm Series i Multiline Terminals

Figure 4-1:	DTR-2DT-1A() TEL	89
Figure 4-2:	DTR-8D-1A() TEL Multiline Terminal	90
Figure 4-3:	DTR-16D-1A() TEL Multiline Terminal	90
Figure 4-4:	DTR-32D-1A() TEL Multiline Terminal	91
Figure 4-5:	Connecting a Multiline Terminal to the System	92
Figure 4-6:	Leading Line Cords on a Multiline Terminal	92
Figure 4-7:	Adjusting the LCD on a Multiline Terminal	93
Figure 4-8:	Installing the Line Card on a Dterm Series i Multiline Terminal	94
Figure 4-9:	Installing the Plastic Panel on a Dterm Series i Multiline Terminal .	94
Figure 4-10:	Removing the Plastic Panel from the Multiline Terminal	95
Figure 4-11:	Attaching Directory Card to Directory Card Holder	96
Figure 4-12:	Attaching Directory Card Holder to the Multiline Terminal	96
Figure 4-13:	Removing the Button Set from a Multiline Terminal	97
Figure 4-14:	Inserting a New Button Set into a Multiline Terminal	97
Figure 4-15:	Locating the Adjustment Tabs on the Multiline Terminal	98
Figure 4-16:	Raising the Height on the Dterm Series i Multiline Terminal	98
Figure 4-17:	Lowering the Base Plate on the Multiline Terminal	98
Figure 4-18:	Removing Base Plate	99
Figure 4-19:	Installing Base Plate	99

Figure 4-20:	Removing the Hanger Hook on a Multiline Telephone	100
Figure 4-21:	Sliding the Hanger Hook into Position	100
Figure 4-22:	Removing the Cutout	101
Figure 4-23:	Bundling the Line Cord	101
Figure 4-24:	Wall Mounting the Base Plate	102
Figure 4-25:	Installing the Telephone	102
Figure 4-26:	Plugging in Line Cord	102
Figure 4-27:	Hiding Excess Cord	103
Figure 4-28:	Removing the Telephone	103
Figure 4-29:	Wall Mounting Base Plate on Switch Box	104
Figure 4-30:	Wall Mounted Telephone	104
Figure 4-31:	Bundling the Line Cord	105
Figure 4-32:	Attaching the Wall Mount Unit to the Wall	105
Figure 4-33:	Attaching the Multiline Telephone to the Wall Mount Unit	106
Figure 4-34:	Plugging in Line Cord	106
Figure 4-35:	Hiding Excess Cord Behind the Wall Mount Unit	107
Figure 4-36:	Removing the Telephone from the Wall Mount Unit	107
Figure 4-37:	Mounting Wall Mount Unit on the Switch Box	108
Figure 4-38:	Wall Mounted Telephone	108

Chapter 5

Installing Dterm Series i Optional Equipment

Figure 5-1:	Locating the Adjustment Tabs on the Multiline Terminal	109
Figure 5-2:	Raising the Base Plate	110
Figure 5-3:	Removing the Multiline Terminal Base Plate	110
Figure 5-4:	Modifying Base Plate for Adapter Installation	111
Figure 5-5:	Connecting the AC Adapter to an Installed Adapter	112
Figure 5-6:	AD(A)-R() Unit	112
Figure 5-7:	Connecting a Multiline Terminal to a Recording Device using an AD(A)-R() Unit (Example)	113
Figure 5-8:	AD(A)-R() Unit Connection without Pause Control	113
Figure 5-9:	AD(A)-R() Unit Connection with Pause Control	113
Figure 5-10:	Removing AD(A)-R() Unit Cover	114
Figure 5-11:	Attaching Cables to the AD(A)-R() Unit	114
Figure 5-12:	AD(A)-R() Unit Cable Access Port	116
Figure 5-13:	AD(A)-R() Switch Default Settings	117
Figure 5-14:	Attaching the AD(A)-R() Unit to the Multiline Terminal	119
Figure 5-15:	Connecting a Multiline Terminal to an Analogue Telephone Using an AP(A)-R() Unit/AP(R)-R() Unit (Example)	120
Figure 5-16:	AP(A)-R() Unit/AP(R)-R() Unit Switches	120
Figure 5-17:	Attaching the AP(A)-R()/AP(R)-R() Units to the Multiline Terminal	122
Figure 5-18:	Installing the Ferrite Core on the AP(A)-R()/AP(R)-R() Units	122
Figure 5-19:	CT(U)-R() Unit	123

Figure 5-20:	Connecting a Multiline Terminal to a PC using a CT(U)-R() Unit (Example)	123
Figure 5-21:	Attaching the CT(U)-R() Unit to the Multiline Terminal	124
Figure 5-22:	Connecting the USB Cable to the CT(U)-R() Unit	125
Figure 5-23:	Attaching the Headset to the Multiline Terminal	125

Chapter 6

Installing DTU-Type Multiline Terminals

Figure 6-1:	DTU-8-1A (WH) TEL Multiline Terminal	127
Figure 6-2:	DTU-8D-1A (BK)/(WH) TEL Multiline Terminal	128
Figure 6-3:	DTU-16D-1A (WH)/(BK) TEL Multiline Terminal	128
Figure 6-4:	DTU-32D-1A (WH)/(BK) TEL Multiline Terminal	129
Figure 6-5:	Connecting a Multiline Terminal to the System	129
Figure 6-6:	Leading Line Cords on a Multiline Terminal	130
Figure 6-7:	Adjusting the LCD	130
Figure 6-8:	Installing Line Card and Plastic Panel on a Multiline Terminal.	131
Figure 6-9:	Installing Plastic Panel	131
Figure 6-10:	Removing the Plastic Panel from the Multiline Terminal	132
Figure 6-11:	Removing Softkeys	132
Figure 6-12:	Locating the Adjustment Tabs on the Multiline Terminal	133
Figure 6-13:	Raising the Base Plate on the Multiline Terminal.	133
Figure 6-14:	Adjusting the Line Cord Length	133
Figure 6-15:	Lowering the Base Plate on the Multiline Terminal	134
Figure 6-16:	Positioning the Handset Hanger.	134
Figure 6-17:	Removing the Knockout	135
Figure 6-18:	Attaching the Base Plate to the Wall	135
Figure 6-19:	Wall Mounting using a Modular Jack	135
Figure 6-20:	Plugging in the Line Cord using a Wall Jack	136
Figure 6-21:	Plugging in the Line Cord Using a Modular Jack	136
Figure 6-22:	Attaching the Bottom Tabs of the Multiline Terminal to the Base Cover.	137
Figure 6-23:	Attaching the Top Tabs of the Multiline Terminal to the Base Plate	137
Figure 6-24:	Installed Wall Mount Unit	138
Figure 6-25:	Removing the Tabs from the Adapter	138
Figure 6-26:	Removing the Tabs from the WMU-UA Unit	139
Figure 6-27:	Leading the Line Cord out of the WMU-UA Unit	139
Figure 6-28:	Attaching the Wall Mount Unit to the Wall	140
Figure 6-29:	Attaching the Multiline Terminal to the WMU-UA Unit	140
Figure 6-30:	Removing the Multiline Terminal from the Base Cover	141
Figure 6-31:	Raising the Base Plate	142
Figure 6-32:	Unlocking Tab	142
Figure 6-33:	Releasing Right Tab.	143
Figure 6-34:	Removing Bottom Cover	143
Figure 6-35:	Removing Base Plate Dummy End	143

Figure 6-36:	Cutting Dummy End in Half	143
Figure 6-37:	Installing Adapter in Connector 1	144
Figure 6-38:	Installing Dummy End B	144
Figure 6-39:	ACA-UA Unit Connection	145
Figure 6-40:	Attaching the ADA-UA Unit to the Multiline Terminal	146
Figure 6-41:	Leading the Audio Cable out from the ADA-UA Unit	146
Figure 6-42:	ADA-UA Unit	147
Figure 6-43:	Attaching Cables to the ADA-UA Unit	147
Figure 6-44:	ADA-UA Unit Switch Settings	149
Figure 6-45:	APR-UA Unit	151
Figure 6-46:	Attaching the Unit to the Multiline Terminal	151
Figure 6-47:	Leading the Telephone Cord out from the Unit	152
Figure 6-48:	Closing the Base Plate Cover	152
Figure 6-49:	APR-UA Unit Switches	152
Figure 6-50:	Connecting Cables on the APR-UA Unit	153
Figure 6-51:	Attaching a Xen Multiline Terminal to a PC	154
Figure 6-52:	CTA-BA Unit	154
Figure 6-53:	Attaching the Unit to the Multiline Terminal	155
Figure 6-54:	Connecting the RS-232C Cable to the CTA-BA Unit on the Multiline Terminal	155
Figure 6-55:	HFU-UA (WH) Unit	156
Figure 6-56:	Microphone with Mute	156
Figure 6-57:	Attaching a Microphone to a Multiline Terminal	156
Figure 6-58:	HFU-UA (WH) Unit Switches	157

Chapter 7

Installing ETW-Type Multiline Terminals

Figure 7-1:	Modular Terminal Connections for Multiline Terminals	160
Figure 7-2:	Connecting an ETW-Type Multiline Terminal	160

Chapter 8

Installing Optional Terminal Equipment

Figure 8-1:	Connecting a Single Line Telephone to the System using an SLT(1)-U13 ADP	161
Figure 8-2:	Connecting the SLT(1)-U13 ADP	162
Figure 8-3:	Removing the Screws from the SLT(1)-U13 ADP	162
Figure 8-4:	Attaching the SLT(1)-U13 ADP to the Wall	163

Chapter 9

Telephone Programming

This page is intentionally blank.

List of Tables

Chapter 1

System Overview

Table 1-1:	Multiline Telephone Loop Resistance and Cable Length	29
Table 1-2:	Cable Connection Between an Analogue Port and the Single Line Telephone	30
Table 1-3:	Power Consumption	31
Table 1-4:	Weights and Dimensions	32
Table 1-5:	Internal and External Battery Specifications	37
Table 1-6:	Tone Patterns	38
Table 1-7:	Multiline Telephone LED Patterns.	41
Table 1-8:	DSS/BLF LED Indications.	42

Chapter 2

KSU Installation

Table 2-1:	KSU Switches and Connections	53
Table 2-2:	DPH-B13 ETU Switch Settings	71
Table 2-3:	TRF-B13 ETU Switch Settings	73
Table 4-4:	CO/PBX Line Loss Compensation	73

Chapter 3

Installing DTB-Type Multiline Terminals

Chapter 4

Installing Dterm Series i Multiline Terminals

Chapter 5

Installing Dterm Series i Optional Equipment

Chapter 6

Installing DTU-Type Multiline Terminals

Table 6-1:	ADA-UA Cable Connections	148
Table 6-2:	ADA-UA Unit Switch Settings	150
Table 6-3:	HFU-UA (WH) Unit Switch Settings	157

Chapter 7

Installing ETW-Type Multiline Terminals

Chapter 8

Installing Optional Terminal Equipment

Chapter 9

Telephone Programming

Table 9-1:	Navigational Keys for Telephone Programming	166
Table 9-2:	Trunk Programming Functions	184
Table 9-3:	Telephone Port Programming	188
Table 9-4:	Trunk Telephone Menu Programming	194
Table 9-5:	Tenant Programming	199
Table 9-6:	System Mode Programming	200
Table 9-7:	Maintenance Modes	201

SECTION 1 YOUR SYSTEM

Your NEC Xen Alpha provides you a complete communications system to enhance your business. The Xen Alpha telephone provides for a maximum of six lines and sixteen telephones. This system is easy to install, operate, and maintain and provides you the benefits and many of the features of a larger key telephone system.

Your system is easy to install, allowing you to have your system up and running in a very short time using the system defaults. Should you need to customise your system, an easy-to-use Windows PC based software is provided. You can also make changes using a telephone.

Your system provides battery backup in case of a power outage. System programming and speed dialling is retained by a long-life lithium battery. The battery located in key service unit (KSU) allows your telephones to continue operating in the event of a power outage.

Xen Alpha is a feature-rich system that provides telephone functions and support many advanced features such as:

- | | |
|---|--|
| <input type="checkbox"/> Computer Telephony Integration (CTI) | <input type="checkbox"/> Uniform Call Distribution |
| <input type="checkbox"/> Call Forward External | <input type="checkbox"/> Automated Attendant |
| <input type="checkbox"/> ISDN-BRI Voice Trunks | <input type="checkbox"/> Automatic Carrier Routing |
| <input type="checkbox"/> Caller ID | <input type="checkbox"/> Trunk to Trunk Transfer |
| <input type="checkbox"/> Integrated Digital Voice Mail | <input type="checkbox"/> Virtual Extensions |

The Xen Alpha system offers a variety of Multiline Terminals. These Multiline Terminals are available in 8-button, 16-button and 32-button capacities and are offered as display and non-display models. A budget and premium range of Multiline Terminals is available.

A customer with existing ETW terminals can easily connect them to the Xen Alpha system, providing inexpensive migration from the NEC Ranger NDK/DK systems. Most Xen Alpha system features are available with the ETW-type Multiline Terminals.

The Xen Alpha systems support a wide range of additional equipment that can be connected to the system to accommodate individual customer needs.

Equipment such as Single Line Telephones, external speakers, facsimile machines, external microphones, and headsets can be connected. The diagram in *Figure 1-1: System Configuration Sample, Pg 20* shows a Xen Alpha system with standard and optional equipment (some locally provided).

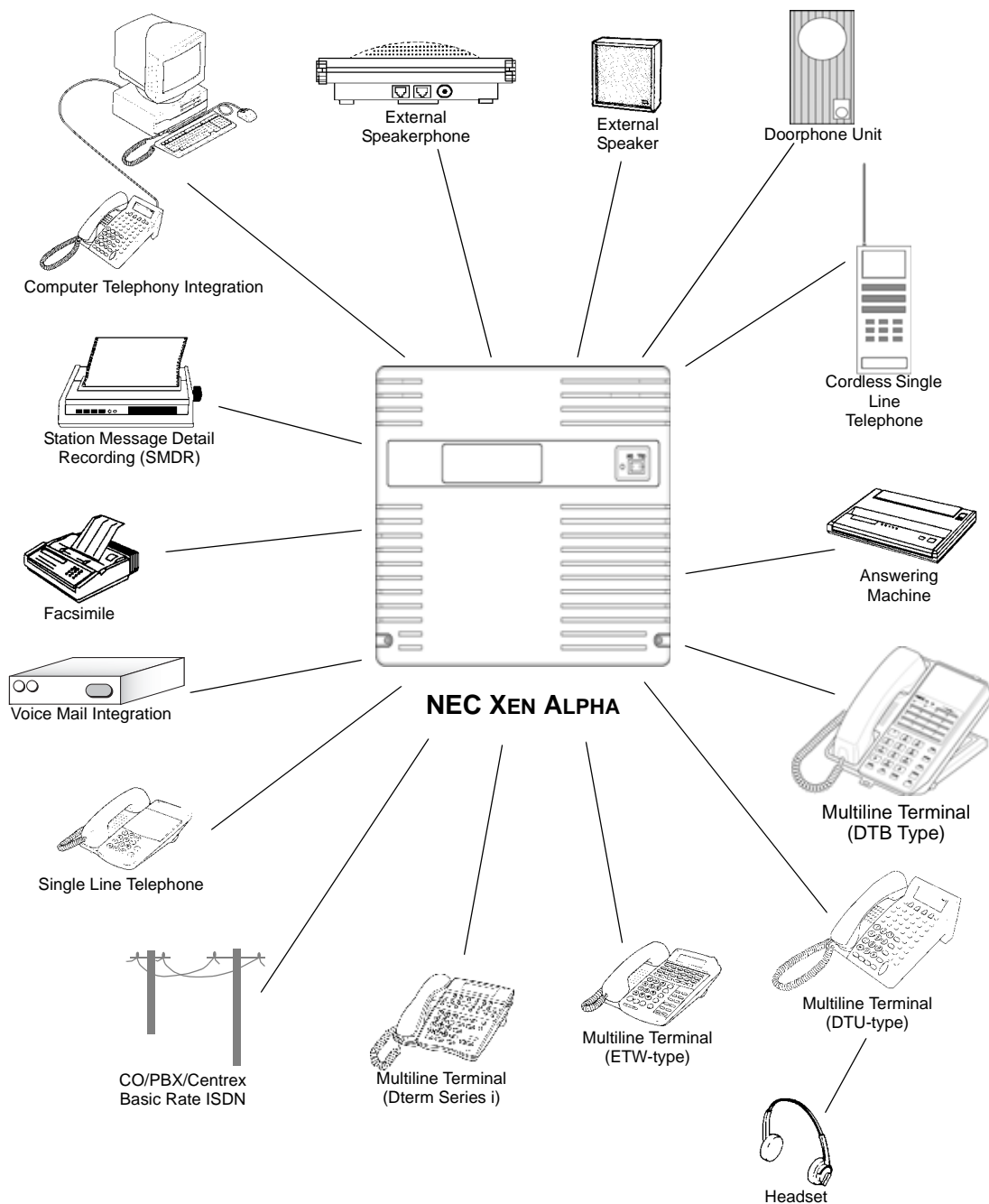

Figure 1-1: System Configuration Sample

Electromagnetic Interference (EMI)

Warning: This is a Class A product. In a domestic environment this product may cause radio interference in which case the user may be required to take adequate measures.

Battery Disposal

The NEC Xen Alpha system includes the following batteries. When disposing of these batteries, KSUs and/or ETUs, you must comply with the rules and regulations of your state regarding proper disposal procedures.

Unit Name	Type of Battery	Quantity
B614-B13 KSU	Lead Acid	2
	Lithium	1
VRS-B13 ETU	NiCd	1

IMPORTANT SAFEGUARDS OF BATTERY DISPOSAL

The product that you have purchased contains a rechargeable battery. The battery must be disposed of properly.

Incidence of Harm

If the System is malfunctioning, it may also be causing harm to the telephone network. The Telephone system should be disconnected until the source of the problem can be determined and until repair has been made. If this is not done, the Network Provider may temporarily disconnect the service.

Hearing Aid Compatibility

The NEC Multiline Terminals that are provided for this system are hearing aid compatible. The manufacturer of Single Line Telephones for use with the system must provide notice of hearing aid compatibility to comply with ACA Technical Standards.

Service Requirements

In the event of equipment malfunction, all repairs should be performed by an authorised dealer of NEC Business Solutions Ltd or by NEC Business Solutions Ltd. It is the responsibility of users requiring service to report the need for service to one of NEC Business Solutions Ltd authorised agents or to NEC Business Solutions Ltd.

Compliance Information

This equipment has been tested to comply with all relevant ACA Technical Standards.

SECTION 3 EQUIPMENT

The following table lists the equipment that is available with your system. The Quantities column indicates the maximum number of pieces of equipment that can be installed for each system.

Equipment	Description	Quantity
Key Service Unit		
B614-B13 KSU	<p>The Basic Key Service Unit (KSU) provides service for outside lines and interconnection of the telephones. The basic KSU supports up to two trunk lines and six telephones.</p> <p>The B614-B13 KSU has a dedicated ESI slot, SLI slot, DPH slot, PBR slot, TRF slot, VRS/VMS slot, 2 x COI/BRT slots and MIF slot.</p>	1 per system
Interface Electronic Telephone Units		
BRT(1)-B13 ETU	<p>This Basic Rate Interface unit provides one circuit for an ISDN Basic Rate Interface (two voice channels).</p> <p>This ETU is installed in the COI/BRT slot.</p>	2 ETUs 4 Trunk Lines
CID-B13 UNIT	<p>The Caller ID Unit detects Caller ID signals from the central office and sends caller identification to the main board. This information is then displayed on the LCD of the telephones.</p> <p>This ETU is installed on the COI(2)-B13 ETU and MB614-B13 Mainboard as a piggyback.</p>	3 Units
COI(2)-B13 ETU	<p>This unit supports two outside (CO/PBX) lines and provides circuitry for ring detection, holding, and dialling.</p> <p>The outside lines must be Loop Start, DTMF or Decadic trunks.</p> <p>This ETU is installed in the COI/BRT slot.</p>	2 ETUs 4 CO/PBX lines
ESI(8)-B13 ETU	<p>The Electronic Station Interface ETU contains eight circuits. Each circuit can support any type of multiline telephone, or single line telephone adapter.</p> <p>This ETU is installed in the ESI slot. A 6 channel ESI circuit is built in on the B614-B13 KSU.</p>	1 ETU 8 Extensions
SLI(2)-B13 ETU	<p>The Single Line Interface ETU supports a maximum of two analogue single line telephones, faxes, modems or other analogue devices. This ETU provides Ringing Signal Generator (RSG) to single line telephones.</p> <p>This ETU is installed in the SLI slot.</p>	1 ETU 2 Extensions
Optional Electronic Telephone Units		
MIF-B13 ETU	This unit provides additional memory for processing and backup for PC programming and SMDR.	1 per system
DPH-B13 ETU	<p>The doorphone interface ETU allows two DP-D-1D Doorphones to be connected. Two door lock release relays are also provided.</p> <p>This ETU is installed in the DPH slot.</p>	1 ETU

Equipment	Description	Quantity
PBR-B13 ETU	The Push Button Receiver ETU detects and translates DTMF tones generated by single line telephones, modems, or facsimile machines. This ETU is installed in the PBR slot.	1 ETU
VMS(2)-B13 ETU	The Voice Mail Service ETU provides two digital voice mail ports. Busy tone detectors are built-in and it uses Flash ROM memory to store the recorded messages. This ETU is installed in the VMS/VRS slot.	1 ETU
VRS-B13 ETU	The Voice Recording Service ETU provides five functions; Automated Attendant, Automatic Answer, Manual Answer, Hold Message and UCD Greetings. This ETU is installed in the VMS/VRS slot.	1 ETU
TRF-B13 ETU	The Trunk Transfer cord allows one trunk to be transferred or forwarded out another trunk, where one of those trunks are analogue. This card provides gain control and call supervision for the transferred call. This ETU is installed in the TRF slot.	1 ETU
DTB-Type Multiline Telephones		
DTB-16-1A (WH) TEL	This digital Multiline Terminal has 8 programmable line keys (each with a two-color LED), 8 programmable one-touch keys (each with a red LED), built-in speakerphone, and a Large LED to indicate incoming calls and messages.	14
DTB-16D-1A (WH) TEL	This digital Multiline Terminal has 8 programmable line keys (each with a two-color LED), 8 programmable one-touch keys (each with a red LED), built-in speakerphone, and a Large LED to indicate incoming calls and messages. This terminal also has a 16-character, 2-line, plus symbols, Liquid Crystal Display (LCD).	14
Dterm Series i Multiline Telephones and Adaptors		
DTR-2DT-1A (BK) TEL	This digital non-display Multiline Terminal has two programmable line keys (each with a 2-colour LED), eight function keys, a built-in speakerphone, headset connection, and a large LED to indicate incoming calls and messages. This telephone has a built-in data port that is available for analogue devices. Each telephone requires a digital port. This terminal does not support adaptors.	14
DTR-8D-1A (BK)/(WH) TEL	This digital Multiline Terminal has eight programmable line keys (each with the 2-colour LED), a built-in speakerphone, headset jack, a Large LED to indicate incoming calls and messages, and compatibility with AD(A)-R(), AP(A)-R(), AP(R)-R() or CT(U)-R() Unit. This terminal also has a 3-line, 24-character, adjustable Liquid Crystal Display (LCD) and four softkeys.	14

Equipment	Description	Quantity
DTR-16D-1A (BK)/ (WH) TEL	<p>This digital Multiline Terminal has 16 programmable line keys (each with a 2-colour LED), a built-in speakerphone, headset jack, a large LED to indicate incoming calls and messages, and compatibility with AD(A)-R(), AP(A)-R(), AP(R)-R() or CT(U)-R().</p> <p>This terminal also has a 3-line, 24-character, adjustable Liquid Crystal Display (LCD) and four softkeys.</p>	14
DTR-32D-1A (BK)/ (WH) TEL	<p>This digital Multiline Terminal has 16 programmable line keys (each with a 2-colour LED), 16 one-touch keys, a built-in speakerphone, headset jack, a large LED to indicate incoming calls and messages, and compatibility with AD(A)-R(), AP(A)-R(), AP(R)-R() or CT(U)-R().</p> <p>This terminal also has a 3-line, 24-character, adjustable Liquid Crystal Display (LCD) and four softkeys.</p>	
ACA-UA Unit	<p>This unit provides power to ancillary devices connected to a Multiline Terminal. The ACA-U() Unit must be connected when an AP(R)-RA adaptor is installed on a Multiline Terminal. When more than one adaptor is installed on a Multiline Terminal, only one ACA-U() Unit is necessary.</p>	14
AD(A)-RA Unit	<p>This Ancillary Device Adapter allows connection of a tape recorder or other audio device to a Dterm Series i Multiline Terminal, except the DTR-2DT-1A() TEL.</p>	14
AP(A)-RA Unit	<p>The Analogue Port Adapter without Ringer is used to install a Single Line Telephone, Modem, Credit Card Reader, Wireless Headset, Conferencing unit, or other compatible analogue devices.</p> <p>The AP(A)-R() Unit can be installed on all Dterm Series i Multiline Terminals except the DTR-2DT-1A() TEL.</p>	14
AP(R)-RA Unit	<p>The Analogue Port Adapter with Ringer is used to install a Single Line Telephone, Modem, Credit Card Reader, Wireless Headset, Conferencing unit, or other compatible analogue devices.</p> <p>The AP(R)-R() Unit can be installed on all Dterm Series i Multiline Terminals except the DTR-2DT-1A() TEL.</p>	14
CT(U)-RA Unit	<p>The Computer Telephony Adapter with USB connection allows a Multiline Terminal to be connected to a PC. The PC can perform all Multiline Terminal functions using a TAPI-compatible application software (Microsoft Telephony Application Programming Interface).</p>	14
WM-RA Unit	<p>This Wall Mount Unit is used to mount any Dterm Series i telephone (except the DTR-2DT-1A() TEL) to the wall when adapters are installed in the terminal.</p>	14

Equipment	Description	Quantity
DTU-Type Multiline Telephones and Adaptors		
DTU-8-1A (WH) TEL	This digital Multiline Terminal has eight programmable line keys (each with a two-color LED), built-in speakerphone, a Large LED to indicate incoming calls and messages, headset jack, and compatibility with ADA-UA, APR-UA, CTA-BA, and HFU-UA Units.	14
DTU-8D-1A (WH)/(BK) TEL	This digital Multiline Terminal has eight programmable line keys (each with a two-color LED), built-in speakerphone, a Large LED to indicate incoming calls and messages, headset jack, and compatibility with ADA-UA, APR-UA, CTA-BA and HFU-UA Units. This terminal also has a 24-character, 3-line, adjustable Liquid Crystal Display (LCD), and provides four softkeys.	14
DTU-16D-1A (WH)/(BK) TEL	These digital Multiline Terminals are equipped with 16 programmable line keys (each with a two-color LED), a built-in speakerphone, a Large LED to indicate incoming calls and messages, headset jack, and compatibility with ADA-UA, APR-UA, CTA-BA and HFU-UA Units. This terminal also has a 24-character, 3-line, adjustable Liquid Crystal Display (LCD), and provides four softkeys.	14
DTU-32D-1A (WH)/(BK) TEL	These digital Multiline Terminals are equipped with 32 programmable line keys (each with a two-color LED), a built-in speakerphone, a Large LED to indicate incoming calls and messages, headset jack, and compatibility with ADA-UA, APR-UA, CTA-BA and HFU-UA Units. This terminal also has a 24-character, 3-line, adjustable Liquid Crystal Display (LCD), and provides four softkeys.	14
ACA-UA Unit	The AC Adapter unit connects to one of the following: APR-UA, ADA-AU, CTA-BA and HFU-UA Units.	One per Multiline Telephone with adapter(s)
ADA-UA Unit	This Ancillary Device adapter provides the digital multiline telephone with connection for a tape recorder. This adapter can be installed on any DTU-Type multiline telephone.	14
APR-UA Unit	When this Analogue Port Ringer adapter is used, an additional single line telephone or a modem can be connected to an DTU-Type multiline telephone. This adapter can be installed on any DTU-Type multiline telephone.	14
CTA-BA Unit	TAPI (Microsoft Telephony Application Programming Interface) Adapter allows an DTU-type Multiline Terminal to be connected to a PC.	14
HFU-UA (BK)/(WH) Unit	This optional Handsfree Unit provides full-duplex handsfree communication. This unit comes with the handsfree adapter and an external microphone. This adapter can be installed on any DTU-Type multiline telephone.	14
WMU-W Unit	This universal Wall Mount Unit is used to mount any ETW-type Multiline Terminal to the wall.	14 Units Max. (1 per ETW Type MLT)

Equipment	Description	Quantity
ETW-Type Multiline Telephones and Adaptors		
ETW-8E-1A (SW) TEL	This terminal is a fully modular instrument with tilt stand, eight Flexible Line keys (each with two-color LED), eight function keys, built-in speakerphone, ADA compatibility, and a large LED to indicate incoming calls and messages.	14
ETW-16C-1A (SW) TEL	This terminal is a fully modular instrument with tilt stand, 16 Flexible Line keys (each with two-color LED), eight function keys, built-in speakerphone, ADA compatibility, and a large LED to indicate incoming calls and messages. This terminal has a 16-character by 2-line Liquid Crystal Display (LCD).	14
ETW-16D-1A (SW) TEL	This terminal is a fully modular instrument with tilt stand, 16 Flexible Line keys (each with two-color LED), eight function keys, 20 programmable One-Touch keys with red LEDs, built-in speakerphone, ADA compatibility, and a large LED to indicate incoming calls and messages. This terminal has a 16-character by 2-line Liquid Crystal Display (LCD).	14
ADA(1)-WA (SW) Unit	This Ancillary Device Adapter provides the ETW-type Multiline Terminal with connection for headset, or audio recorder.	14
WMU-UA Unit	This Wall Mount Unit is used to mount any DTU-type Multiline Terminal to the wall. This unit connects to the back side of the Multiline Terminal. This unit is required when an APR-UA Unit, CTA-BA Unit or HFU-UA (WH) Unit is installed.	14 Units Max. (1 per DTU-Type MLT)
Optional Units		
SLT(1)-U13 ADP	This Adapter provides an interface for single line telephones and other similar devices from an ESI ETU channel. This adapter is connected to any ESI port.	2
DP-D-1D Unit	This Door Phone unit has a handsfree microphone and speaker and a push-button for the visitor to alert internal extensions of their presence. This unit is wall mounted and weather resistant.	2
Software		
PC Programming	System programming software for easy and convenient installation via a PC.	N/A

SECTION 4 SYSTEM CAPACITIES

The Xen Alpha KSU has nine dedicated slots, two for the COI/BRT ETUs and one each for the ESI, SLI, VMS/VRS, DPH, TRF, MIF and PBR ETUs. Each COI ETU, including the MBD has support for the CID ETU.

Some capacities of the Xen Alpha system are listed below.

Category	Item	Standard or Option	Quantity		Comments
System	Dedicated slots	S	9		1 COI or BRT 2 COI or BRT 3 SLI 4 MIF 5 ESI 6 DPH 7 VMS or VRS 8 TRF 9 PBR
	MOH/BGM Input	S	1		
	Control Relay	S	1		Either External Paging Control or External Ringer Control.
	External Paging Zone	S	1		
	Internal Paging Zones	S	2		
	Tenants	S	2		
	Conference	S	4		
	System Speed Dial	S	80	400	Selectable mode.
	Station Speed Dial	S	20	0	
	PBR Circuit	O	4		
	SMDR Port	O	1		Shared port.
	PC Programming Port	O	1		
	Trunk	Analogue CO/PBX Trunks	2S, 4O	6	
Basic Rate ISDN Interfaces		O	2 (4ch)		
Analogue Caller ID Circuits		O	6		
Trunk Transfer Circuit		O	1		
Station	MLT	6S, 8O	14		Combined total of 14 Extensions.
	SLT via SLT Adapter	O	2		
	SLT via SLI Card	O	2		
	Voice Mail Ports	O	2		
	Door Phone Circuits	O	2		One shared voice path.
	Door Lock Release Circuits	O	2		
	Power Fail Transfer	S	2		Dual purpose ports.
	Fax Connections	S	2		
	VRS Channels	O	1		
	Computer Telephony Interfaces	O	14		
	Voice Mail Integration	O	2		
Virtual Extensions	5	13		Uninstalled ESI Ports	

SECTION 5
SYSTEM BLOCK
DIAGRAM

Figure 1-2: NEC Xen Alpha System Block Diagram – represents an installed system. This diagram shows the ETUs that can be installed in the KSU and the number of channels that are supported when the ETU is installed.

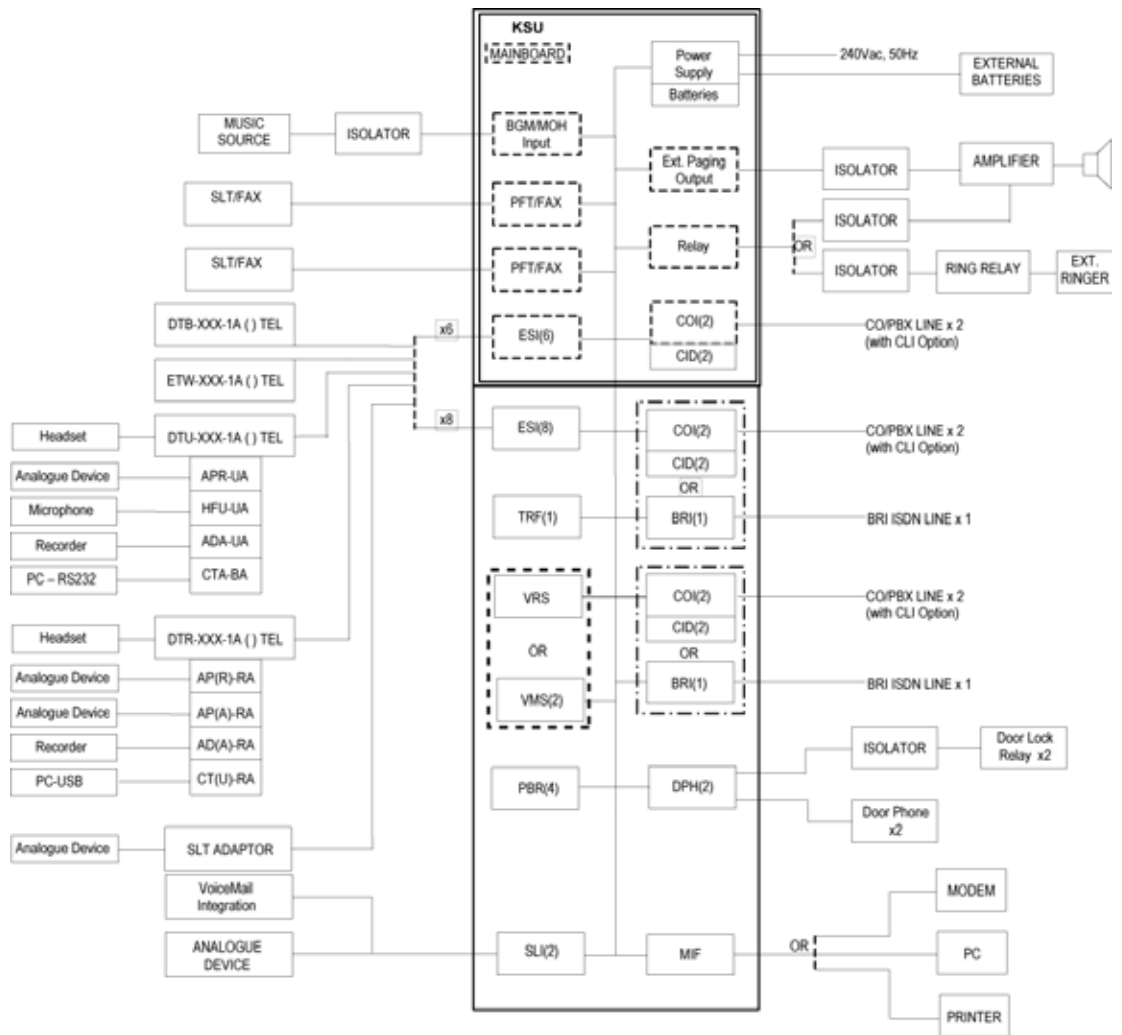

Figure 1-2: NEC Xen Alpha System Block Diagram

SECTION 6
CABLING
REQUIREMENTS
&
SPECIFICATIONS

This section provides cabling requirements and specifications for various equipment used in the Xen Alpha system.

- ❑ BRT(1)-B13 ETU
- ❑ COI(2)-B13 ETU
- ❑ DPH-B13 ETU
- ❑ ESI(8)-B13 ETU
- ❑ SLI(2)-B13 ETU

The KSU is connected with each of the Multiline Telephones and Single Line Telephones by a separate twisted 1-pair cable or 2-pair cable (only for Multiline Telephones). (Refer to *Table 1-1: Multiline Telephone Loop Resistance and Cable Length*, Pg 29 for the loop resistance and cabling requirements for Multiline Telephones and adapters.)

Table 1-1: Multiline Telephone Loop Resistance and Cable Length

Terminal or Adapter	Maximum Loop Resistance (Ohms)	Maximum Metres by Twisted 1-Pair Cable 24 AWG	Maximum Metres by Twisted 2-Pair Cable 24 AWG
DTB-16-1A () TEL	26	135	270
DTB-16D-1A () TEL	26	135	270
DTR-2DT-1A() TEL	37	500	500
DTR-8D-1A() TEL	37	210	420
DTR-16D-1A() TEL	35	200	400
DTR-32D-1A() TEL	26	150	300
DTU-8-1A () TEL	35	180	300
DTU-8D-1A () TEL	35	180	300
DTU-16D-1A () TEL	26	135	270
DTU-32D-1A () TEL	21	110	215
SLT(1)-U13 ADP	35	180	300
ETW-8E-1A (SW) TEL	35	180	300
ETW-16C-1A (SW) TEL	26	135	270
ETW-16D-1A (SW) TEL	21	110	215

Note 1: The length specified for the SLT Adapter is the length between the SLT Adapter and the ESI port.

Figure 1-3: Connecting the ESI to the Multiline Telephone Using Twisted 2-Pair Cable

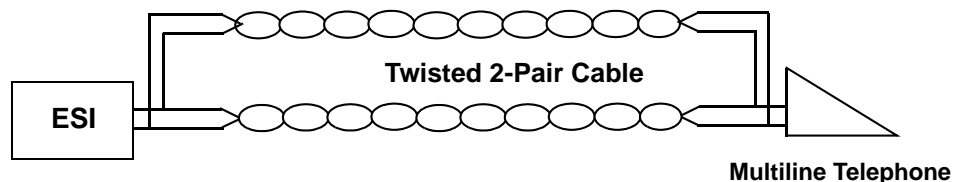

Table 1-2: Cable Connection Between an Analogue Port and the Single Line Telephone

Connected Equipment	Cable	Maximum Loop Resistance from Connected Equipment to Telephone	Maximum Distance by Twisted 1-Pair Cable (24 AWG)
APR-UA ADP/AP(R)-RA ADP	Twisted Pair	600	200 m
SLT(1)-U13 ADP	Twisted Pair	600	200 m
SLI(2)-B13 ETU	Twisted Pair	600	200 m

Note 1: Mixing digital and analogue ports through the same 25-pair cable runs is not recommended.

Note 2: The Maximum Loop Resistance includes the internal resistance of the SLT device.

SECTION 7
POWER
REQUIREMENTS

Power Supply Inputs

The AC input requirements for the Xen Alpha system are listed below:

AC Input

- 240 Vac + 10/-15 %
- 50 Hz ± 2 Hz
- Single Phase
- 10A Circuit
- A dedicated outlet, separately fused and grounded, is required.

Power Supply Consumption

The power consumption for the Xen Alpha system is listed in *Table 1-3: Power Consumption, Pg 31*.

Table 1-3: Power Consumption

KSU	Maximum RMS Current	Watts Used (Idle)	Watts Used (Maximum)
B614-B13 KSU	0.35A	30W	80W

SECTION 8
ENVIRONMENTAL
CONDITIONS

Temperature

- Maximum Operating: 0°C ~ 40°C (+32°F ~ +104°F)
- Recommended Long Term: 10°C ~ 32.2°C (+50°F ~ +90°F)

Humidity

- Operating: 10% ~ 90% noncondensing

SECTION 9 WEIGHTS & DIMENSIONS

Table 1-4: *Weights and Dimensions* shows shipping weight, height, width, and depth of each KSU, Multiline Telephone, and adapter.

Table 1-4: Weights and Dimensions

Unit	Shipping Weight*	Height	Width	Depth
ACA-UA Unit	638 g	86 mm	107 mm	133 mm
AD(A)-R() Unit	113 g	56.25 mm	68.76 mm	137.5 mm
ADA-UA Unit	65 g	29 mm	59 mm	99 mm
AP(A)-R() Unit	158 g	26.25 mm	68.75 mm	137.5 mm
AP(R)-R() Unit	158 g	26.25 mm	68.75 mm	137.5 mm
APR-UA Unit	122 g	66 mm	59 mm	121 mm
B614-B13 KSU	6500 g	320 mm	385 mm	124 mm
BRT(1)-B13 ETU	130 g	93 mm	138 mm	21 mm
CID(2)-B13 UNIT	98 g	60 mm	110 mm	28 mm
COI(2)-B13 ETU	185 g	93 mm	138 mm	29 mm
CTA-BA Unit	122 g	66 mm	59 mm	121 mm
CT(U)-R() Unit	239 g	56.25 mm	68.75 mm	137 mm
DP-D-1D Doorphone	238 g	38 mm	140 mm	121 mm
DPH-B13 ETU	140 g	93 mm	138 mm	21 mm
DTB-16-1A(WH) TEL	1100 g	231 mm	168 mm	86 mm
DTB-16D-1A(WH) TEL	1180 g	231 mm	168 mm	86 mm
DTR-2DT-1A()TEL	1163 g	100 mm	195 mm	243 mm
DTR-8D-1A()TEL	1233 g	122 mm	260 mm	250 mm
DTR-16D-1A()TEL	1233 g	122 mm	260 mm	250 mm
DTR-32D-1A()TEL	1361 g	122 mm	260 mm	250 mm
DTU-16D-1A (WH)/(BK) TEL	1233 g	123 mm	197 mm	235 mm
DTU-32D-1A (WH)/(BK) TEL	1361 g	123 mm	220 mm	235 mm
DTU-8-1A (WH) TEL	1163 g	123 mm	197 mm	235 mm
DTU-8D-1A (WH)/(BK) TEL	1233 g	123 mm	197 mm	235 mm
ETW-16C-1A (SW) TEL	992 g	101 mm	175 mm	223 mm
ETW-16D-1A (SW) TEL	1106 g	101 mm	205 mm	223 mm
ETW-8E-1A (SW) TEL	907 g	101 mm	175 mm	223 mm
ESI(8)-B13 ETU	185 g	93 mm	138 mm	20 mm
HFU-UA (WH)/(BK) Unit	201 g	86 mm	107 mm	133 mm
MIF-B13 ETU	340 g	93 mm	138 mm	21 mm

Table 1-4: Weights and Dimensions (Continued)

Unit	Shipping Weight*	Height	Width	Depth
PBR-B13 ETU	70 g	75 mm	65 mm	20 mm
SLI(2)-B13 ETU	170 g	93 mm	138 mm	24 mm
SLT(1)-U13 ADP	255 g	45 mm	70 mm	120 mm
TRF-B13 ETU	100 g	93 mm	138 mm	15 mm
VMS(2)-B13 ETU	250 g	93 mm	138 mm	37 mm
VRS-B13 ETU	120 g	93 mm	138 mm	20 mm
WM-R() Unit	301 g	104 mm	151 mm	180 mm
WMU-UA Unit	301 g	104 mm	151 mm	180 mm

* Shipping weight includes the shipping carton.

SECTION 10 OUTSIDE LINE TYPE

The following outside line types can be used with the Xen Alpha system.

- 2-wire, Loop Start Trunks
- ISDN-BRI Trunks

SECTION 11 NETWORK & CONTROL

Transmission, Network & Control Specifications

Transmission

- Data Length
 - From Multiline Telephone to ESI(8)-B13 ETU: 13 bytes
 - From ESI(3)-B13 ETU to Multiline Telephone: 13 bytes
- Data Transmission Rates:
 - Between ESI(8)-B13 ETU and Multiline Telephone: 176 bps (voice and signalling)
- Scanning Time for each Multiline Telephone: 64 ms.

Network

Time Division Multiplexing allows transmission of a number of separate data, voice and/or video simultaneously over one communications medium. The information below indicates the specifications the Xen Alpha system uses for switching, clock, data bus, time-frame.

- TDM Switching: PCM (A-Law)
- TDM Clock: 2.048 MHz
- TDM Data Bus: 16 bit
- TDM Time-frame: 125 μ s

Control

This section indicates the speed and capacities of the control.

- Control: Stored program with distributed processing
- Central Processor: 8-bit microprocessor
- Clock: 12.288 MHz
- Sub-processor: 8-bit microprocessor
- Multiline Telephone: 8-bit microprocessor
- SLT Adapter: 4-bit microprocessor

Telephone

The voltage, current, ring signal information for the Xen Alpha multiline telephones, single line telephone equipment, and APR units are listed below.

- Multiline Telephone
 - Voltage: -11 ⇔ -26 Vdc
 - Maximum Current: 250 mA
- Single Line Telephone
 - Nominal Current: 35 mA
 - Ring Signal: 56 Vac RMS @ 20 Hz
- SLT(1)-U13 ADP
 - Nominal Current: 30 mA
 - Ring Signal: 56 Vac RMS @ 20 Hz
- APR-UA Unit
 - Nominal Current: 30 mA
 - Ring Signal: 70 Vac RMS @ 18 Hz

SECTION 12
DIALLING
SPECIFICATIONS

Dial Pulse Address Signalling

Dial Pulse Signalling is a type of address signalling that uses dial pulses (regular momentary interruptions) to signal the equipment. In the Xen Alpha system, the following Dial Pulse specifications are used.

- Pulse Rate: 10 ± 1 pps/20 ± 2 pps
- Percent Break: 60 ± 1.5%
- Inter-digit Interval: Break Period – 60 to 70 ms
 Make Period – 30 to 40 ms

Dual-Tone Multifrequency (DTMF) Address Signalling

DTMF signalling is a term that describes push button or Touchtone dialling. When a key on a telephone is pushed, two tones (one high frequency and one low frequency) are provided. In the Xen Alpha system, the following DTMF specifications are used.

- Frequencies
 Two sinusoidal frequencies are provided, one from the high frequency group and one from the low frequency group.
- Frequency Deviation: Less than ±1.5%
- Signal Level:
 Nominal level per frequency: -22 to 05 dBm
 Minimum level per frequency: Low Group: -22 dBm
 High Group: -22 dBm
 Maximum level per frequency: 0 dBm
- Rise Time: Within 5 ms
- Duration of Dual Frequency Signal:
 - 110 ms default/60 ms. minimum
- Inter-digital Time: 80 ms default/70 ms minimum

		Nominal High Group Frequencies (Hz)		
		1209	1336	1477
Nominal Low Group Frequencies (Hz)	697	1	2	3
	770	4	5	6
	852	7	8	9
	941	*	0	#

SECTION 13

EXTERNAL EQUIPMENT CONNECTION

Music Sources for Music on Hold via KSU

- Auxiliary Input: 0.6V PPS Signal Level
- Input Impedance: 600 Ω

Music Source for Station Background Music via KSU

- Auxiliary Input: 0.6V PPS Signal Level
- Input Impedance: 6 00 Ω

External Paging (Audio) via KSU

- Output Power: -10 dBm Signal Level
- Output Impedance: 600 Ω

External Tone Ringer Output

- Output Level: -10 dBm
- Output Impedance: 600 Ω
- Relay Contact Rating: 1A, 24 Vdc

SMDR Output

- Male Connector Standard RS232C (DB9)

PC Connection

- Male Connector Standard RS232C (DB9)

Relay Contact

- All Relay Contact Ratings: 1A, 24Vdc

SECTION 14 BATTERY BACKUP

The Xen Alpha system has battery backup functions for system backup and for memory backup.

System Backup

During a mains power failure, the system's operation can be backup up using rechargeable batteries. The internally mounted backup batteries can support all system operations for a minimum of 20 minutes. If longer backup duration's are required, larger externally mounted batteries can be connected. The recommended battery size, as shown in *Table 1-5: Internal and External Battery Specifications, Pg 37* below, can support all system operations for a minimum of 3 hours.

Table 1-5: Internal and External Battery Specifications

Specification	Internal Battery	External Battery
Weight	350 g	2.6 kg
Terminal Type	Leaded, JST VHR-2N	Leaded, JST VHR-2N
Size: Length	96 mm	151 mm
Width	25 mm	65 mm
Height	62 mm	94 mm
Max. Discharge Current	2.1 A	2.1 A
Voltage Rating	12 V	12 V
Current Capacity	0.7 Ah	6.5 Ah
Minimum Backup Duration	20 Mins	3 Hrs

CAUTION

Do not short circuit batteries. The battery could explode and cause damage to personnel and equipment.

Danger of explosion if battery is incorrectly replaced. Replace only with the same or equivalent type recommended by the manufacturer. Dispose of used batteries according to the manufacturer's instructions.

Memory Backup



The B614-B13 KSU has a Lithium battery installed to provide backup of system memory. The following functions will be retained for approximately 2 years when the battery is fully charged. (The battery is not recharged by the system.)



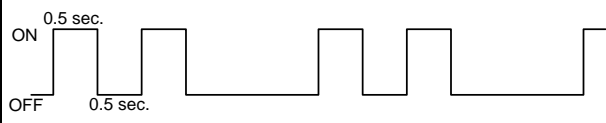
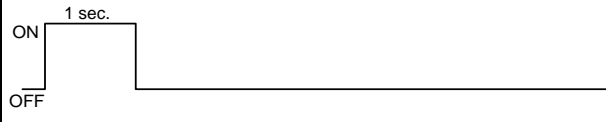
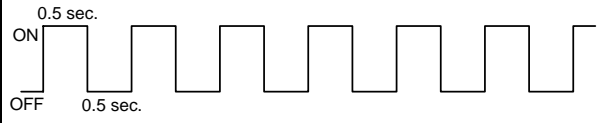
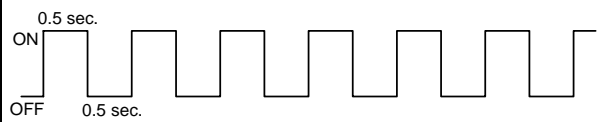
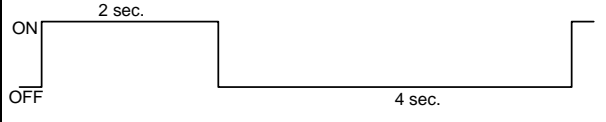
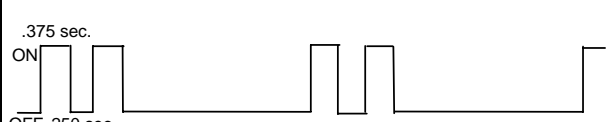
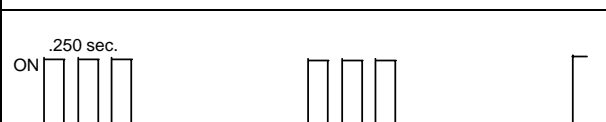
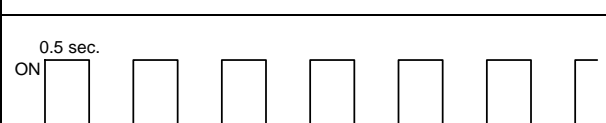
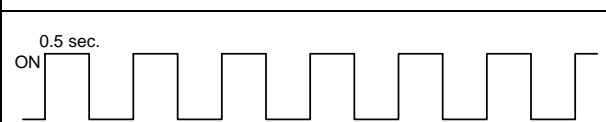
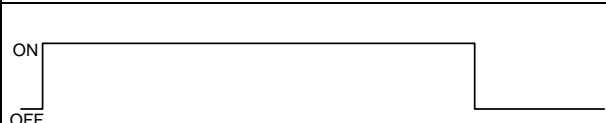

- Background Music
- Call Forwarding
- Clock/Calendar
- Do Not Disturb (DND)
- Last CO/PBX Redial
- Message Waiting
- Microphone Status
- Room Monitor
- Speed Dial Memories (System and Station)
- System Programming
- Timed Alarm
- Volume Control/LCD Contrast

SECTION 15
VISUAL &
AUDIBLE
INDICATIONS

Tone Patterns Table

Table 1-6: Tone Patterns

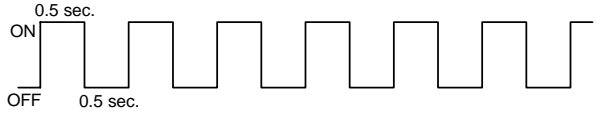
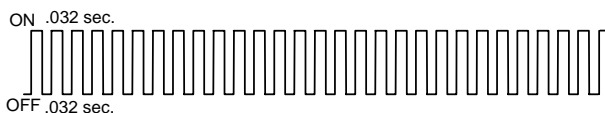
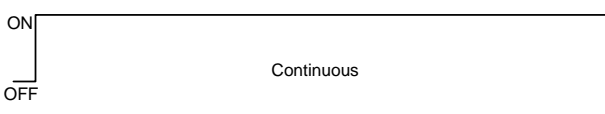
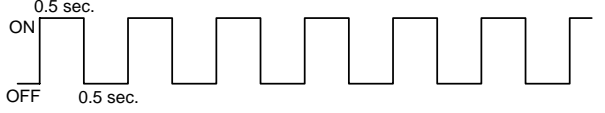
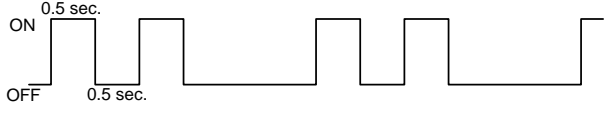
System Tone (Fixed)		Frequency (Hz) (Fixed)	Modulation	Cycle
Automatic Callback		500 Hz (I) 540 Hz (D)	N/A	
Barge-In Tone		440 Hz	N/A	
Busy Tone		480 Hz 620 Hz	N/A	
Call Waiting Tone		440 Hz	N/A	
CO/PBX Ring Tone A		High: 1024 Hz/1285 Hz (I) 1100 Hz/1400 Hz (E) Low: 480 Hz/606 Hz (I) 520 Hz/660 Hz (E)	16	
CO/PBX Ring Tone B		High: 1024 Hz/1285 Hz (I) 1100 Hz/1400 Hz (E) Low: 480 Hz/606 Hz (I) 520 Hz/660 Hz (E)	16	
CO/PBX Ring Tone C		High: 1024 Hz/1285 Hz (I) 1100 Hz/1400 Hz (E) Low: 480 Hz/606 Hz (I) 520 Hz/660 Hz (E)	16	
CO/PBX Ring Tone D		High: 1024 Hz/1285 Hz (I) 1100 Hz/1400 Hz (E) Low: 480 Hz/606 Hz (I) 520 Hz/660 Hz (E)	16	
CO/PBX DIT Ring		Low: 480 Hz/606 Hz (I) 520 Hz/660 Hz (E)	16	
Door- phone 1	Chime Tone	N/A	N/A	
	Busy Chime Tone	1400 Hz/1100 Hz (I & E)	N/A	

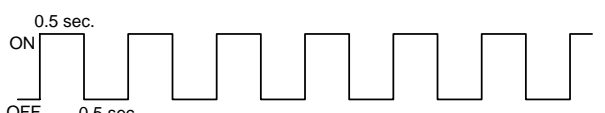
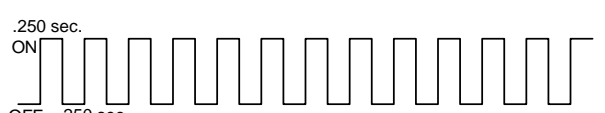
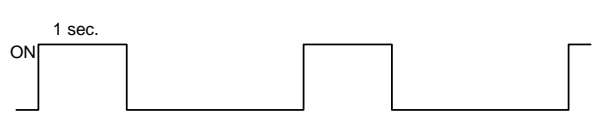
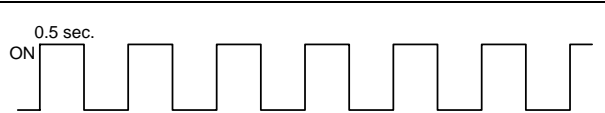
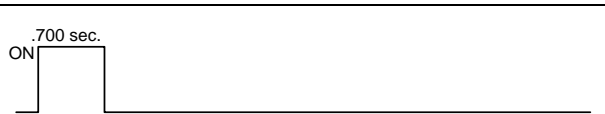
System Tone (Fixed)		Frequency (Hz) (Fixed)	Modulation	Cycle
Door- phone 2	Chime Tone	N/A	N/A	
	Busy Chime Tone	1024 Hz (I) 1100 Hz (E)	N/A	
Hold Alarm		1024 Hz (I) 1100 Hz (E)	N/A	
Howler Tone		2400 Hz (I & E)	16 100% AM	
Incoming Dial Tone		360 Hz/440 Hz (I & E)	N/A	
Incoming Ring Transfer		480 Hz/606 Hz (I) 520 Hz/660 Hz (E)	16	
Internal Ring Tone		500 Hz (I) 540 Hz (E)	N/A	
Key Tone		1100 Hz (I & E)	N/A	
Recall Tone		1024 Hz (I & E)	N/A	
Reorder Tone		480/620 Hz	N/A	
Ringback Tone for External Speaker CO/PBX Ring Tone		440 Hz/480 Hz (I & E)	N/A	
Ringing Transfer Alarm		1024 Hz (I) 1100 Hz (E)	N/A	
Set Tone 1		800 Hz (I & E)	N/A	

System Tone (Fixed)	Frequency (Hz) (Fixed)	Modulation	Cycle
Set Tone 2	500 Hz (I) 540 (E)	N/A	<p>0.5 sec. ON OFF</p>
Timed Alarm	1024 Hz (I) 1100 Hz (E)	N/A	<p>.250 sec. ON OFF .125 sec.</p>
Tone Override	500 Hz (I) 540 HZ (E)	N/A	<p>2 sec. ON OFF</p>
Trunk Queuing	500 Hz (I) 540 HZ (E)	N/A	<p>0.5 sec. ON OFF 0.5 sec.</p>

Multiline Terminal Flash Patterns Table

Table 1-7: Multiline Telephone LED Patterns

LED	Condition	Col.	Flash Pattern				
Line Key	I-Use	Green	—	—	—	—	—
	Busy	Red	—	—	—	—	—
	Incoming Call	Red	— — —	— — —	— — —	— — —	— — —
	I-Hold	Green	—	—	—	—	—
	Call Hold	Red	—	—	—	—	—
	Hold Recall	Green	— — —	— — —	— — —	— — —	— — —
	Transfer Recall	Green	— — —	— — —	— — —	— — —	— — —
Microphone	ON	Red	—	—	—	—	—
	Monitored	Red	—	—	—	—	—
ICM	I-Use	Red	—	—	—	—	—
	ICM Incoming Call	Red	— — —	— — —	— — —	— — —	— — —
Large LED	Incoming Internal Call	Red	— — —	— — —	— — —	— — —	— — —
	Incoming CO Line	Green	— — —	— — —	— — —	— — —	— — —
	Voice Mail Message	Red	—	—	—	—	—
Speaker	ON	Red	—	—	—	—	—
	System Data Entry	Red	—	—	—	—	—
	Monitor	Red	—	—	—	—	—
Conference	Conference in Progress	Red	—	—	—	—	—
	All Conference Circuits in Use	Red	—	—	—	—	—
	Hold Conference Call	Red	—	—	—	—	—
	ICM Call Hold	Red	— — —	— — —	— — —	— — —	— — —
	SPD Confirmation	Red	— — —	— — —	— — —	— — —	— — —
Answer	Incoming Trunk	Red	— — —	— — —	— — —	— — —	— — —
	Preset	Red	—	—	—	—	—
Call	Trunk Selected	Green	—	—	—	—	—
	Preset	Red	—	—	—	—	—
	No Trunks Available	Red	—	—	—	—	—
Function	Callback Set	Red	— — —	— — —	— — —	— — —	— — —
	DND, Call FWD	Red	— — —	— — —	— — —	— — —	— — —
	Auto Redial Set	Red	— — —	— — —	— — —	— — —	— — —
	ON (to Set Function)	Red	— — —	— — —	— — —	— — —	— — —
LNR/SPD	CO Line Key Seized	Green	—	—	—	—	—
	Exclusive Hold	Green	—	—	—	—	—
BLF or DSS Key	Use, Hold, ICM Called	Red	—	—	—	—	—
	DND, Call Fwd All Set	Red	—	—	—	—	—
	Special Mode (While pressing FNC key or going off-line)	Red	—	—	—	—	—

0 0.5 1.0 1.5 2.0 sec

DSS/BLF LED Indications Table

Table 1-8: DSS/BLF LED Indications

Function	Colour	Status
Idle		OFF
Talking	Red	ON
Hold	Red	ON
FWD All & DND	Red (flashing)	ON
Other Use (Multiline Terminal is in off-line mode, the station user is programming, Feature Access/One-Touch Key programming, etc.)	Red (flashing)	ON

SECTION 1 GENERAL INFORMATION

This section provides the requirements for installing the system. The installer should be familiar with this section before installing the system.

SECTION 2 SITE PREPARATION

The technician should plan the installation before actual work begins. Advanced planning will minimise time, cost and disruption of the customer's business activities. Additional benefits include flexibility for changes and expansion, efficient maintenance and increased customer satisfaction.

Precautionary Information

The following warnings shall be observed during installation:

1. Never install telephone wiring during a lightning storm.
2. Never install telephone jacks in wet locations unless the jack is specifically designed for wet locations.
3. Never touch uninsulated telephone wires or terminals unless the telephone line has been disconnected at the network interface.
4. Use caution when installing or modifying telephone lines.

Site Survey

In most cases, a survey of the customer's premises is needed to develop cost estimates of the installation. Preliminary information is used to determine the placement of the Main Distribution Frame (MDF). A second visit to the site may be necessary to obtain the exact dimensions of the area selected for MDF, cable lengths and possible IDF (intermediate Distribution Frame) locations.

Site Limitations

Installation of a telephone system is seldom a routine procedure. The uniqueness of each customer's situation requires a **tailored** approach to each job. In selecting a permanent site for the MDF, the technician may encounter problems such as, but not limited to the following:

- Limited space is available and must be used regardless of its suitability.
- The available space may be adequate, but may pose one or more environmental hazards.
- The proposed location has limitations. Such as insufficient lighting or the lack of a suitable ground for grounding the KSUs.

Whatever the nature of the adversities encountered, the technician must make the necessary decisions to arrive at the best possible solution for installing the equipment. It is beyond the scope of this document to cover all possible situations, precautions and actions.

Site Selection Conditions

KSU Installation Site

The following conditions should be met at the site selected for the KSU.

- The KSUs should be wall mounted to protect against accident or flooding.
- The KSU should not be located directly beneath pipes, due to the possibility of leaks or condensation causing damage to the equipment.
- The area where the KSU is to be located must be free of corrosive and inflammable gases, excessive chemical or industrial dusts and other materials that could cause a hazard to personal or to the proper functioning of the equipment.
- Operating ambient temperature and humidity must be within the limits specified in **Section 8** – Environmental Conditions in Chapter 1.
- The operation of the system is virtually noiseless and allows a wide selection of installation sites. Care should be taken to ensure the KSUs do not present a hazard to office traffic. For purposes of economy, a central location to minimise cabling is often used.
- The basic KSU weighs approximately 4 Kg. Select a strong wall for mounting purposes.
- Place the KSU according to the following spacing specifications
 - Space distance between the KSU and the ceiling: 50 cm or more
 - Space distance on both sides of the KSU: 30 cm or more
 - Space distance on front of KSU: 50 cm or more
- Avoid connection of the KSU to an AC receptacle used in common with any other device (computer, facsimile machine, copier, etc.)
- Ensure that any AC Outlet to be connected is properly grounded.
- Avoid connection of KSU near radio receivers or electrical noise generators (e.g. welding equipment, machinery).

CAUTION

1. The socket outlet shall be installed near the equipment and shall be easily accessible.
 2. Plug the system into the mains supply (240V AC) before terminating a telecommunications network conductor to the system.
 3. Danger of explosion if batteries are incorrectly replaced. Replace only with the same or equivalent type recommended by the manufacturer. Dispose of used batteries according to the manufacturers instructions
-

SECTION 3 INSTALLING THE KEY SERVICE UNIT (KSU)

Multiline Telephone Installation Site

The following conditions should be met at the site selected for MLTs.

- Ensure the cable length and line resistance (loop), between the KSU and the telephones comply with the specifications shown in *Table 1-1: Multiline Telephone Loop Resistance and Cable Length* – , Multiline Telephone Loop Resistance and Cable Length.
- Some devices require an external power supply. Select a place where they can be easily connected to an AC outlet.
- Telephones intended for handsfree use should be kept away from areas subject to loud noise or echoing.

Installation Precautions

Before installation and cabling of the KSU, observe the below precautions.

- Before starting the work, be sure the KSU power switch is OFF and disconnect the power cord from the AC outlet.
- Do not directly touch the soldered surfaces of the ETUs with you hands.
- Extreme care must be taken to avoid STATIC DISCHARGE when handling ICs and ETUs – an earthed wrist strap must be worn.

The Key Service Unit

The B614-B13 KSU is the system cabinet that houses a power supply, battery backup and fixed slots for installing option/expansion cards. The KSU is wall mounted. (Refer to *Figure 2-1: Front View of a KSU*, Pg 45.)

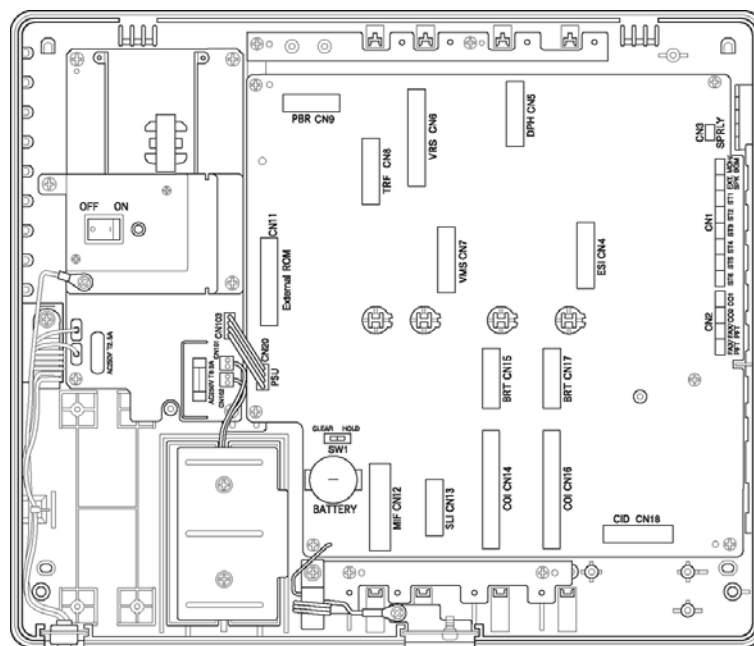

Figure 2-1: Front View of a KSU

Removing the KSU Cover

Before wall mounting the KSU, the KSU cover must be removed. Below is a diagram showing how to remove the cover of the KSU.

1. Remove the cover by loosening the two bottom screws with a philips head screwdriver (the screws remain in the cover to keep from misplacing them). Pull the cover away from the KSU and lift upward.

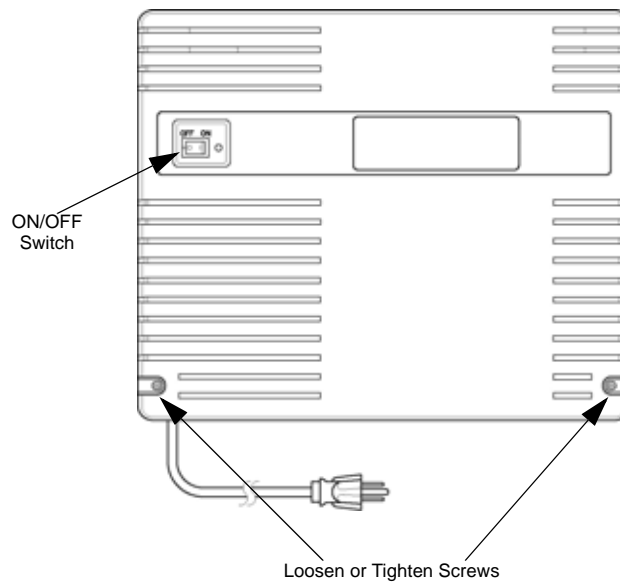

Figure 2-2: How to Remove the KSU Cover

2. To replace the cover, locate the tabs on the top of the cover into the slots in the top of the base and then push the bottom of the cover inwards. Tighten the two cover screws.

Wall Mounting the KSU

Before wall mounting the KSU, it is recommended that the wall mounting screws be attached to the piece of plywood (13 mm thick or more) or attached to a sturdy wall.

1. Using two of the four screws (provided with the KSU) attach the wall mount template to the wall. (Refer to *Figure 2-3: Attaching the Wall Mounting Bracket for the KSU to the Wall*, Pg 47.)

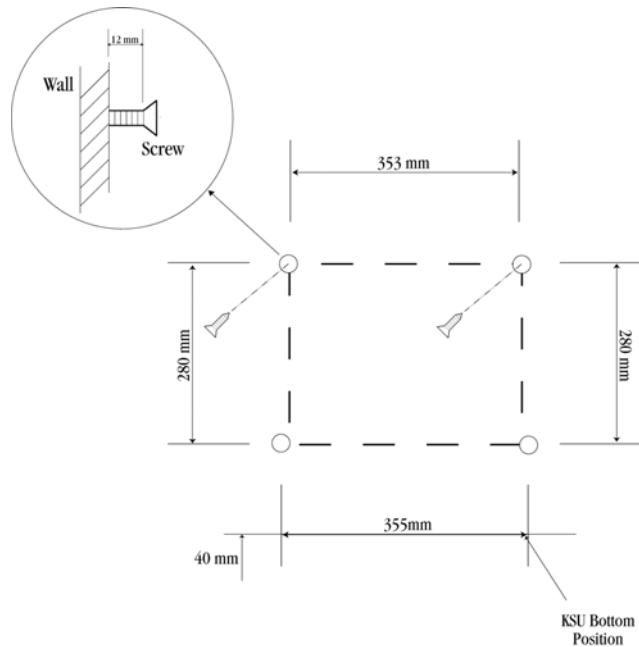

Figure 2-3: Attaching the Wall Mounting Bracket for the KSU to the Wall

2. While holding the KSU, hang the upper two openings that are located in the KSU base over the wall mount template. (Refer to *Figure 2-4: Attaching the KSU to the Wall Mount Template*, Pg 47.)

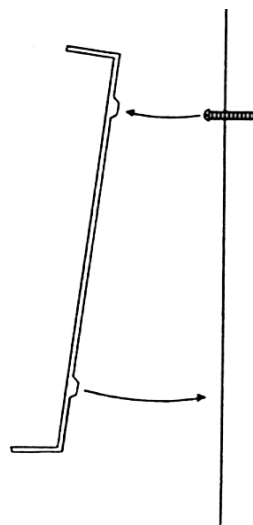

Figure 2-4: Attaching the KSU to the Wall Mount Template

- Using the other two provided screws, secure the KSU to the wall mount template by screwing the lower two openings located in the KSU base. (Refer to *Figure 2-5: Securing the KSU to the Wall Mount Template, Pg 48.*)

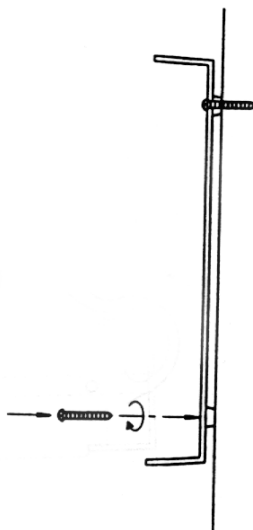

Figure 2-5: Securing the KSU to the Wall Mount Template

Installing or Replacing the Internal Backup Batteries

These batteries provide power for the system in case of a power outage.

- Be sure the system is turned **off** during the installation process.
- Remove the cover by loosening the two bottom screws with a philips head screwdriver (the screws remain in the cover to avoid misplacing them). Pull the cover away from the KSU and lift upward.
- Remove the screw that is attached to the grounding cable and loosen the second screw that secures the metal plate to the batteries. Slide the metal plate until it clears the remaining screw and lift upward to remove the metal plate.
- If replacing existing batteries, detach the battery cables from the connector terminals CN3 (BATT1) and CN4 (BATT2). Lift out the old batteries.
- Insert the new batteries into the slots. Place the notched end of the battery toward the casing on the KSU. Place the battery cables between the inside of the battery and the posts located on the inside of the battery casing.

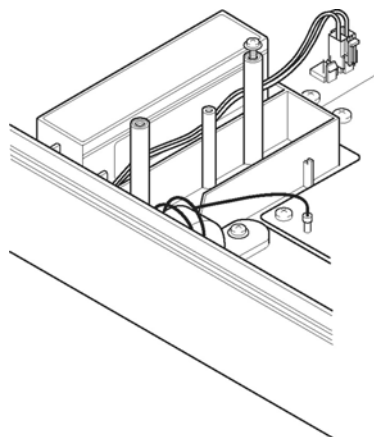

Figure 2-6: Inserting a New Battery in the KSU Unit

6. Replace the metal plate on top of the new batteries. Place the grounding cable on top of the hole and tighten the screw using a philips head screwdriver.
7. Attach the battery connectors to CN3 (BATT1) and CN4 (BATT2) battery terminals. Insert the battery connectors over either battery terminal. The connector tab should be placed over the terminal tab. There is only one direction the tabs can be placed into the connector terminals, therefore you cannot attach them incorrectly.

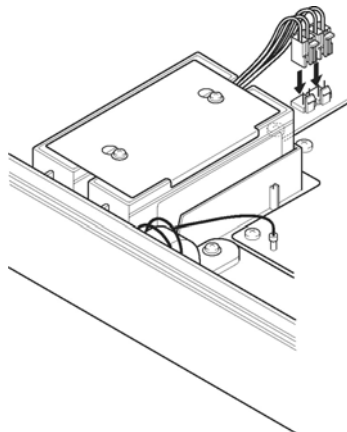

Figure 2-7: Attaching the Battery Connectors

8. Attach the cover and tighten the screws.
9. Turn the power on.

IMPORTANT SAFEGUARDS FOR BATTERY DISPOSAL

DO NOT PLACE USED BATTERIES IN YOUR REGULAR TRASH! THE PRODUCT YOU PURCHASED CONTAINS A NICKEL-CADMIUM OR SEALED LEAD ACID BATTERY. NICKEL-CADMIUM OR SEALED LEAD ACID BATTERIES MUST BE COLLECTED, RECYCLED OR DISPOSED ON IN AN ENVIRONMENTALLY SOUND MANNER.

The incineration, land filling or mixing of nickel-cadmium or sealed lead batteries with the municipal solid waste stream is PROHIBITED BY LAW in most areas. Contact your local solid waste management officials for other information regarding the environmentally sound collection and disposal of the battery.

CAUTION

Do not short circuit batteries. The battery could explode and cause damage to personnel and equipment.

Danger of explosion if battery is incorrectly replaced. Replace only with the same or equivalent type recommended by the manufacturer. Dispose of used batteries according to the manufacturer's instructions.

Connecting External Backup Batteries

1. Disconnect the Built-in Backup Battery Cables from CN3 and CN4 on the Power Supply. Position the loose battery cables safely inside the KSU.
2. Mount the external battery into the External Battery Cabinet (AKB-A-ZD ETU), as follows:

Note: Two batteries must be connected per KSU and each cabinet houses just one battery.

- a.) Remove the four cover screws.
- b.) Pass the battery cables through the hole in the left side of the cabinet and connect to the battery terminals.

Note: RED CABLE TO ⊕
BLUE CABLE TO −

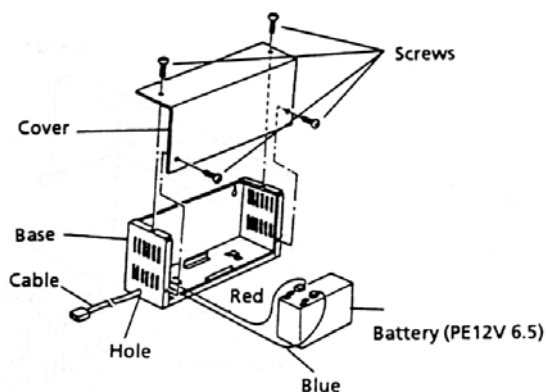

- c.) Mount the battery into the cabinet and secure it using the U-shaped bracket with two screws.

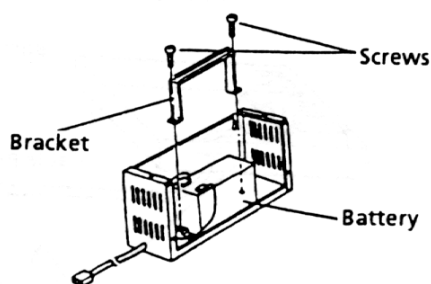

- d.) Secure the battery cables using the grommet supplied.

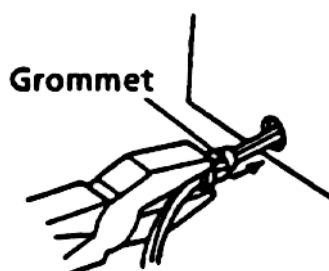

3. Mount the two External Battery Cabinets close to the KSU using the wood screws supplied and replace the cover using the four screws. (Refer to *Figure 2-8: Mounting the External Battery Cabinet, Pg 51.*)

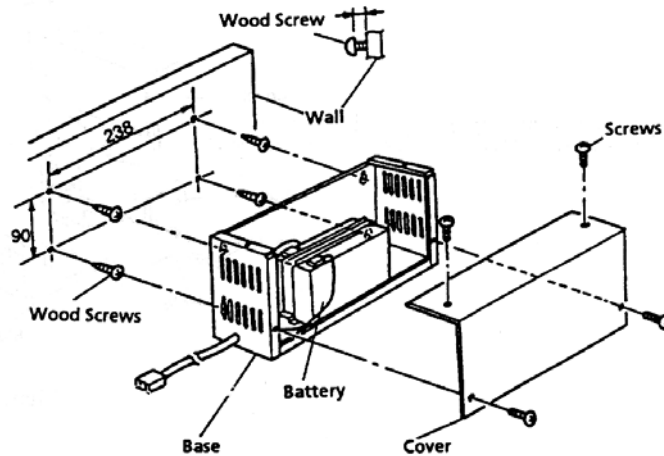

Figure 2-8: Mounting the External Battery Cabinet

4. Connect the two external cable assemblies to CN3 and CN4 on the power supply. (Refer to *Figure 2-9: Connecting External Batteries, Pg 51.*)

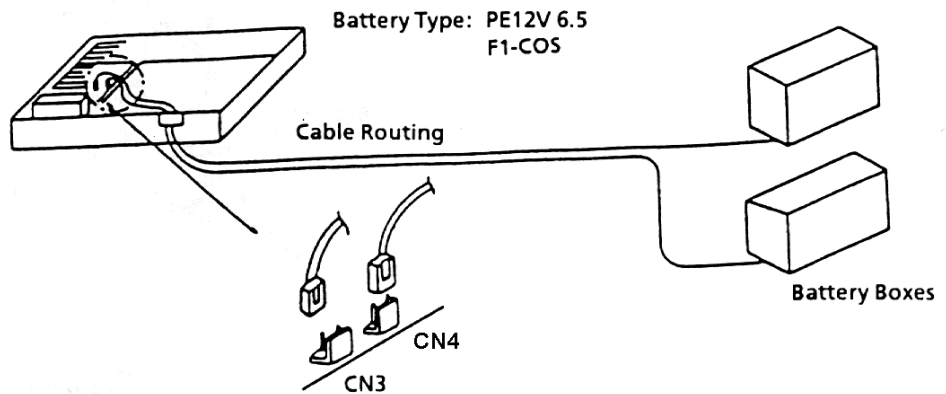

Figure 2-9: Connecting External Batteries

Grounding Requirements

The KSU must be properly grounded. This can be achieved by a correctly wired AC outlet. If there is any uncertainty, obtain advice from a licensed electrical contractor. Where a ground (other than conduit ground) is used, a grounding terminal is provided on a B614-B13 KSU. (Refer to *Figure 2-10: KSU Grounding, Pg 52.*)

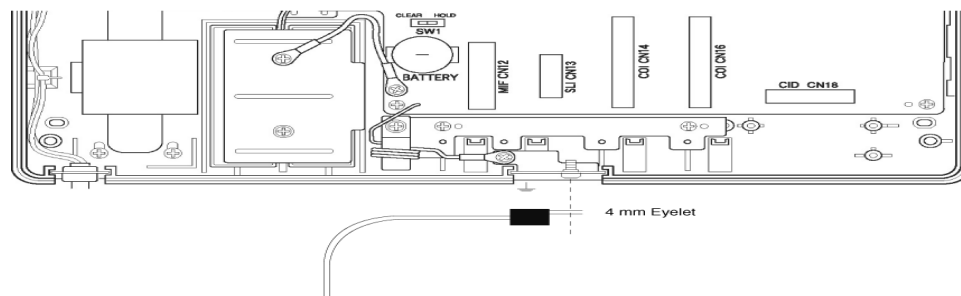

Figure 2-10: KSU Grounding

Connecting the B614-B13 KSU

The CPU is the central processing unit (CPU). An 8-bit microprocessor executes the programs stored on the ROM ICs to control the whole system, while transferring data to and from other ETUs.

The KSU consists of a main control section and a Time Division Switch (TDSW) section. It also has an external ringer interface six 4-party conference circuits, two CO/PBX interfaces, six station interfaces and two power failure transfer circuits.

The RAM memory, on the CPU is back up with a non-rechargeable lithium battery which will retain the memory for up to 18 months.

Switch Settings

Before programming System Data, the non-rechargeable lithium battery must be switched on (SW1→HOLD) to allow memory content retention in case of a power failure or brownout. Failure to activate the backup battery circuit may result in System Data being reset to the default values, the status of all stations will reset to the default values and the data programmed on the station may clear if a power failure or brownout occurs. (If programming using a Multiline Terminal, refer to Chapter 2, Programming in this manual for instructions.)

NOTE: Wait at least 30 seconds after turning on system power before changing memory switch SW1 from CLEAR to HOLD.

When the KSU is removed for long term storage, switch off the lithium battery (SW1→CLEAR). This will prevent the battery from constantly discharging. The battery, when fully charged will retain memory contents for a minimum of three months. (Refer to *Figure 2-11: KSU Switch Settings, Pg 53* and *Table 2-1: KSU Switches and Connections, Pg 53.*)

To clear the system memory, use the following procedure.

1. Turn system power OFF.
2. Change SW1 to CLEAR position.
3. Turn system power ON.
4. After waiting at least 30 seconds, change SW1 to HOLD position.

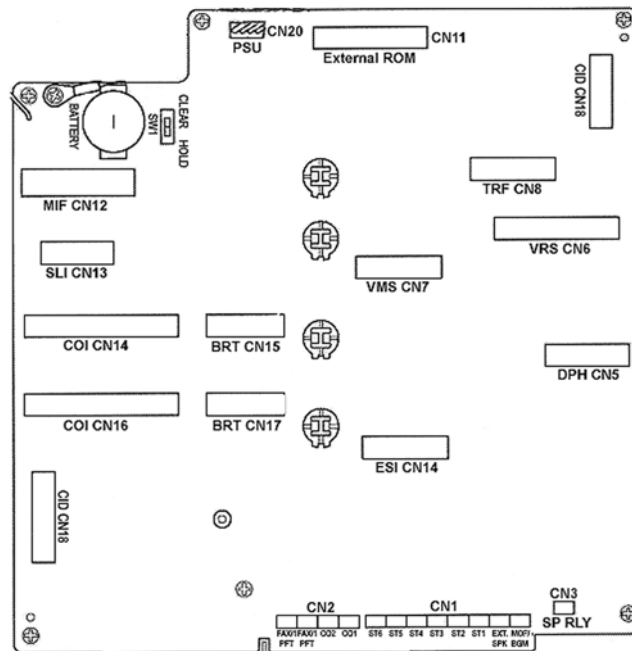

Figure 2-11: KSU Switch Settings

Table 2-1: KSU Switches and Connections

Name	Default Setting	Description/Purpose
SW1	CLEAR	System Memory Battery Backup (Hold/Clear)
CN1	ST 1⇨6 EXT.SPK MOH/BGM	ESI Station Ports 1⇨6 External Paging Speaker Music on Hold and Background Music Source
CN2	CO 1⇨2 FAX/PFT 1⇨2	Analogue Trunks 1⇨2 Fax or Power Fail Transfer Ports 1⇨2
CN3	RLY	External Paging Amplifier or External Ringer Control Relay
CN4	ESI	ESI(8)-B13 ETU
CN5	DPH	DPH-B13 ETU
CN6	VRS	VRS-B13 ETU
CN7	VMS	VMS(2)-B13 ETU
CN8	TRF	TRF-B13 ETU
CN9	PBR	PBR-B13 ETU
CN11	External ROM	ROM Board
CN12	MIF	MIF-B13 ETU
CN13	SLI	SLI(2)-B13ETU
CN14	COI	COI(2)-B13 ETU
CN15	BRT	BRT(1)-B13 ETU
CN16	COI	COI(2)-B13 ETU
CN17	BRT	BRT(1)-B13 ETU
CN18	CID	CID(2)-B13 ETU
CN20	PSU	Power Supply CN103

Telephone Connections

The B614-B13 ETU supports the connection of 6 digital extensions via CN1. Each port requires a single twisted pair cable and the connection is not polarity conscious. (Refer to *Figure 2-12: Telephone Connection, Pg 54*)

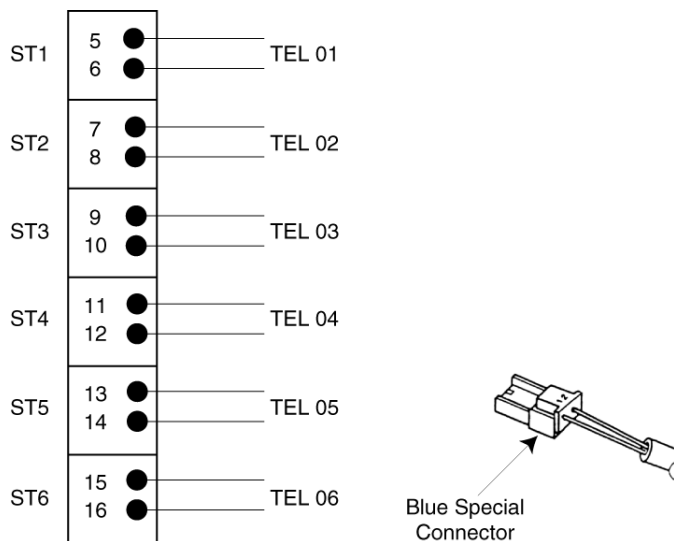

Figure 2-12: Telephone Connection

Exchange Line Connection

The B614-B13 ETU supports the connection of 2 analogue exchange lines (Central Office or PABX) via CN2. This 2-wire connection is not polarity conscious. (Refer to *Figure 2-13: Exchange Line Connection, Pg 54*.)

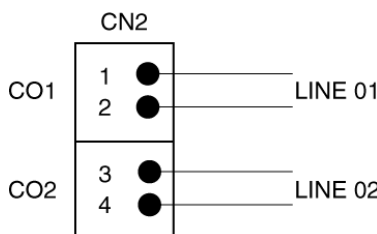

Figure 2-13: Exchange Line Connection

Power Fail Telephone and Fax Connection

The B614-B13 ETU supports the connection of 2 analogue telephones via CN2 for use during period of power failure (i.e. when AC power is lost and the system backup batteries are depleted). Connection of each 2 wire analogue telephone is shown in *Figure 2-14: Power Fail Telephone and Fax Connection, Pg 55*. In the event of a power failure the analogue telephones are connected immediately to a CO/PBX line as follows:

FAX/PFT1 → CO1
(CN2, pins 5-6)

FAX/PFT2 → CO2
(CN2, pins 7-8)

A detailed explanation of the operation and usage of Power Fail Telephones is given at the end of Section 5.

If not required as power fail telephone ports, the FAX/PFT ports of CN2 can be used to connect other analogue equipment such as faxes and modems. These devices can make and receive calls as per the normal operation, when the associated trunks are not in used by other users of the system. Note that each device is dedicated to a trunk (CO1 or CO2) as indicated above. Any activity by these devices will be shown as a busy trunk status on the handsets of other users on the system.

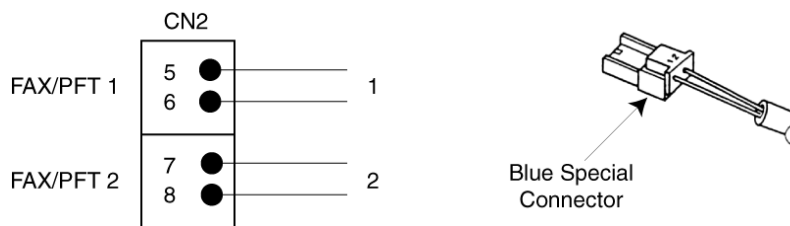

Figure 2-14: Power Fail Telephone and Fax Connection

External Ringer and External Paging Control Connection

The B614-B13 ETU supports the connection of an External Ringer, via CN3-RLY, which can be used to activate a locally supplied loud sounding alarm. This alarm can be programmed to sound while an incoming CO/PBX, DID or DIT call is ringing and is ideal for large or noisy areas, or for the hearing impaired. The output of CN3 is a no-voltage relay contact operation with the following specifications.

Cadence (Cycle): 1 second ON (closed)/2 seconds OFF (open)
 Maximum Voltage: 24 Vdc
 Maximum Current: 1A

Alternatively, CN3-RLY can be programmed to operate as an External Paging Amplifier Controller. In this mode, the relay of CN3 will close when an external page is initiated and will remain closed until the page is terminated. This no-voltage signal can be used to turn on (and off) the locally supplied external paging amplifier. But not that the voltage and current limits shown above will always apply!

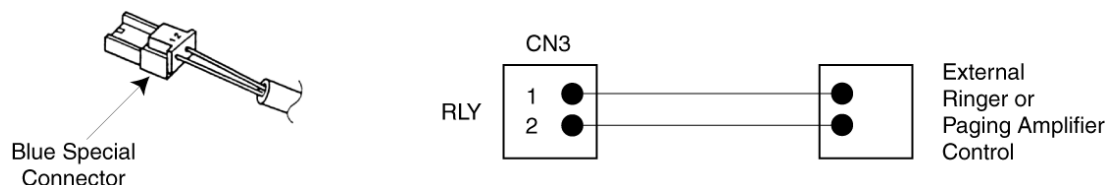

Figure 2-15: External Ringer Connection

External Speaker Connection

The B614-B13 ETU provides one pre-amp level output for connection of an External Paging System. This paging system would include as a minimum, a Line Isolation Unit, Audio Amplifier and Speaker. As well as external paging, this speaker may also be sued as alert upon incoming external calls.

If On/Off control of the amplifier is required, Memory Block 001-0 must be set. Then when an External Page is performed, that control relay will close providing a dry indication to the amplifier. (Refer to External Ringer and External Paging Control connection.)

If a Paging Alert Tone is required to precede each External Paging message, Memory Block 002-3 must be set.

The paging equipment terminates onto the EXT.SPK connector of CN1 using a Special Connector. If amplifier on/off control is required, this terminates onto the General Purpose Relay connector (CN3-RLY), again using a Special Connector.

Connection of this equipment must be via a Line Isolation Unit with an ACA Telecommunications compliance label. The Batesford Electronics Model BE-104 is an example.

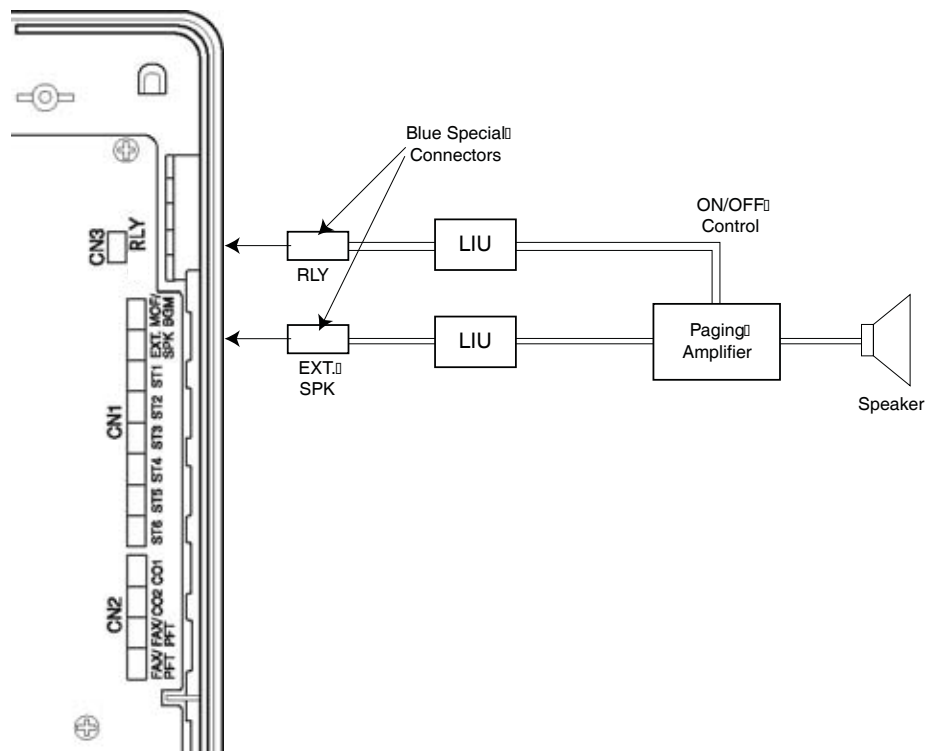

Figure 2-16: External Paging Connection

External Music-On-Hold (MOH)/Background Music (BGM) Source Connection

The B614-B13 ETU can be used to connect an external music source for use with the Music-On-Hold and Background music facilities e.g. radio, CD player or tone source.

Connect two wires from the music source to the MOH/BGM connection of CN1 (using a Blue Special connector). This is not polarity sensitive.

Connection of this equipment must be via a Line Isolation Unit with an ACA Telecommunications compliance label. The Batesford Electronics Model BE-104 is an example.

Adjust the music source to a suitable level by making an internal call, placing it on Hold and listening to the music whilst adjusting the output level of the music source itself.

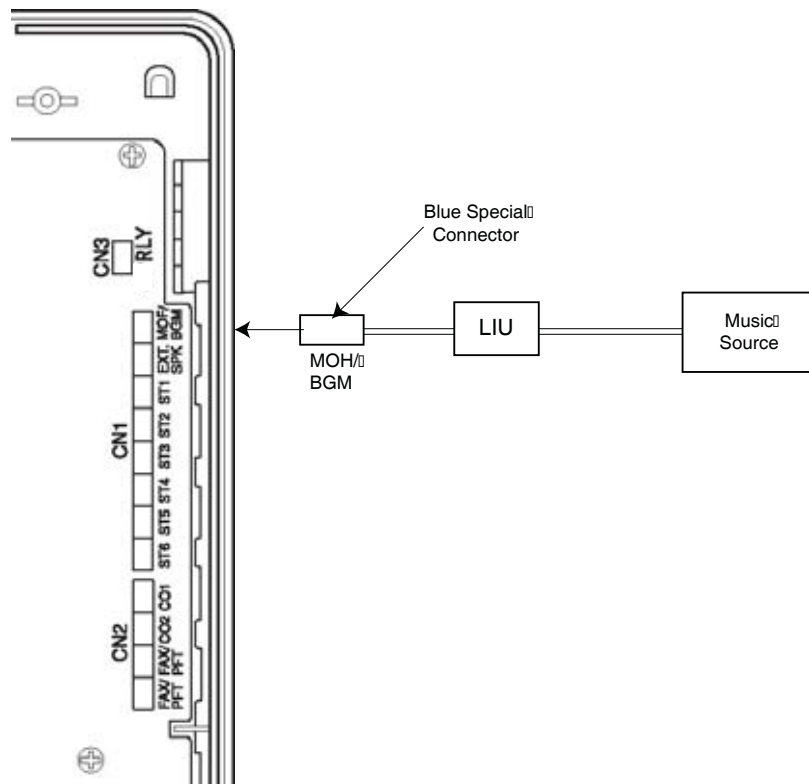

Figure 2-17: MOH/BGM Source Connection

External ROM Card

To upgrade the main system software of the Xen Alpha you will need an External ROM card and an EPROM containing the new software. The ROM card can be used to upgrade many systems and can be reused as new software versions are released by fitting a new EPROM.

Preparing the ROM Card:

1. Carefully remove the ROM card from its packaging, using a wrist strap connected to protective earth to avoid static discharge.
2. Mount the new EPROM onto the ROM card into socket ICI.

NOTE: Check for correct orientation of the EPROM and ensure that all pins are properly aligned over the socket before firmly pushing in the EPROM.

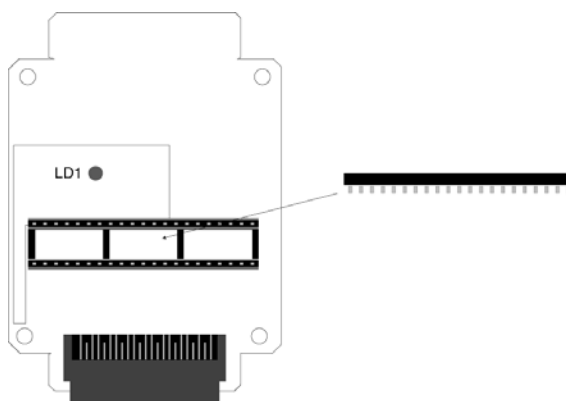

Figure 2-18: External ROM Card

To upgrade a Xen Alpha system:

1. Use PC Programming, download and 'save to disk' the current system setup.
2. Switch the system OFF.
3. Remove the cover from the KSU.
4. Clear system memory (refer to page 36).
5. Locate connector CN11 (marked **External ROM**) on the mainboard and plug the ROM card into it.

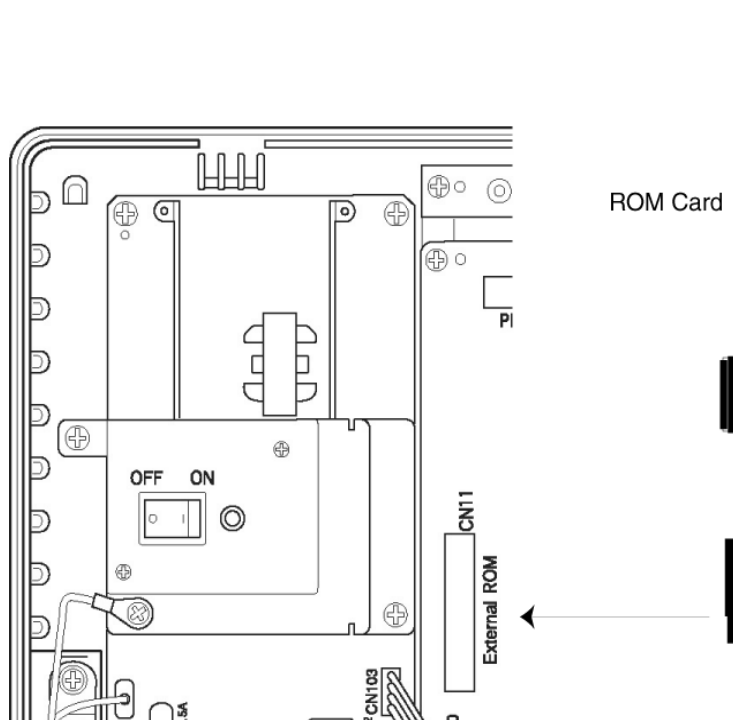

Figure 2-19: Inserting the External ROM Card

6. Turn the system ON. LED LD1 on the ROM card and the LIVE LED on the mainboard will light red. The ROM LED on the mainboard will flash red to indicate that the program is in the process of being transferred.
7. Once the ROM LED has stopped flashing, turn the system OFF and remove the ROM card.
8. Replace the KSU cover.
9. Turn the system ON.
10. Using PC Programming, upload the saved system setup.

SECTION 4 INSTALLING AN ELECTRONIC TELEPHONE UNIT (ETU)

General Information

Installation Precautions

Before installation of the ETUs, observe the below precautions.

1. To prevent accidental damage to equipment, the power must be OFF during installation and maintenance.
2. The ETUs used in this system make extensive use of CMOS technology. CMOS technology is very susceptible to static; therefore **extreme care** must be taken to avoid static discharge when handling ETUs.

ETU Installation

Be sure to mount the ETUs in the correct position inside the KSU. Make any connections and switch settings on the ETUs before inserting them in the KSU. Also refer to *Figure 2-20: Installing a Vertically Mounted ETU, Pg 60.*)

CAUTION

When a ETU is installed or removed, ensure that the power switch of the KSU is in the OFF position.

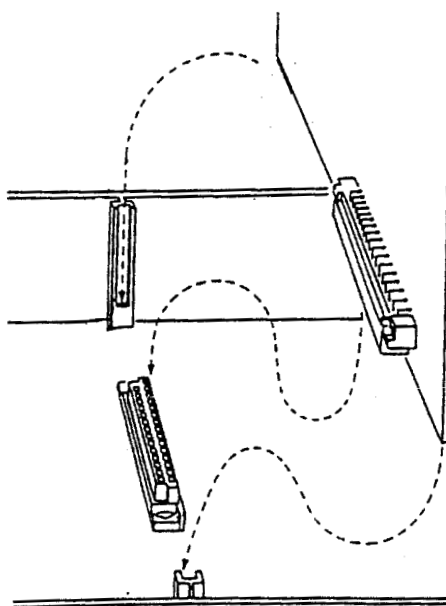

Figure 2-20: Installing a Vertically Mounted ETU

Interface ETUs

ESI(8)-B13 ETU

The ESI ETU is an interface for Multiline Telephones and SLT Adapters and allows a further eight such devices to be connected to the system. One ESI(8)-B13 ETU can be installed in the system, providing a total of 14 Multiline telephones. These ESI ports are arranged as follows:

Mainboard (Built-in ESI) → Extension Ports 01 to 06

ESI(8)-B13 ETU (CN4) → Extension Ports 07 to 14

To install the ESI(8)-B13 ETU:

1. Ensure that the system is turned OFF.
2. Remove the cover from the KSU.
3. Carefully remove the ETU from its packaging, using a wrist strap connected to the frame ground on the KSU to avoid static discharge.
4. Locate connector CN4 (marked ESI) on the mainboard and slide the ETU between the posts. Press the ETU down firmly to lock into place.
5. Using a philips head screwdriver, secure the ETU to the KSU by tightening the screw captive in the metal bracket on the ETU.
6. Run the ESI cabling from the ETU to the external MDF. A single twisted-pair is required for each connection and this is not polarity sensitive. Crimp the special connector supplied to each cable pair.
7. Replace the KSU cover.
8. Turn the system ON.
9. Program the system as required, although the additional ports are automatically assigned default values.

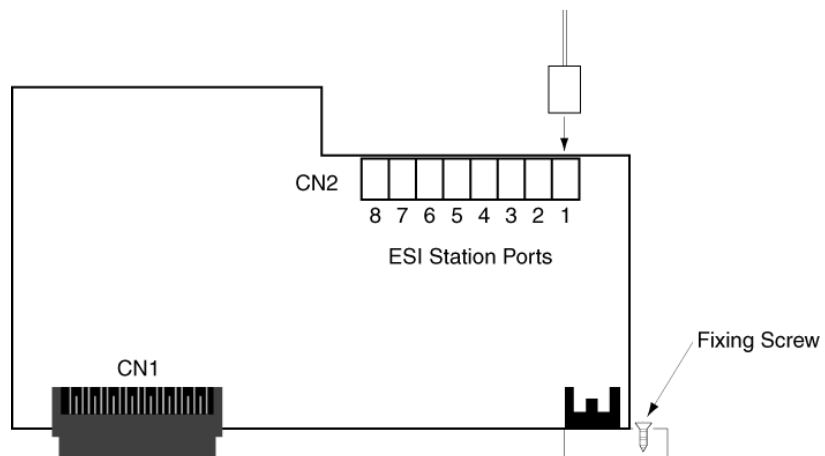

Figure 2-21: ESI(8)-B13 ETU

SLI(2)-B13 ETU

The SLI ETU is an interface for two Single Line telephones or other analogue devices such as cordless telephones, facsimiles, modems, answering machines or external voice mail system. One SLI(2)-B13 ETU can be installed in the system, taking the total number of extension ports to 16. These ports are numbered as follows:

Mainboard (Built-in ESI) → Extension Ports 01⇒06

ESI(8)-B13 ETU (CN4) → Extension Ports 07⇒14

SLI(2)-B13 ETU (CN13) → Extension Ports 15⇒16

To install the SLI(2)-B13 ETU:

1. Ensure that the system is turned OFF.
2. Remove the cover from the KSU.
3. Carefully remove the ETU from its packaging, using a wrist strap connected to the frame ground on the KSU to avoid static discharge.
4. Using a philips head screwdriver, secure the ETU to the KSU by tightening the screw captive in the metal bracket on the ETU.
5. Run the SLI cabling from the ETU to the external MDF. A single twisted-pair is required for each connection, this is not polarity sensitive. Crimp the special connector supplied to each cable pair.
6. Replace the KSU cover.
7. Turn the system ON.
8. Program the system as required, although the additional ports are automatically assigned default values.

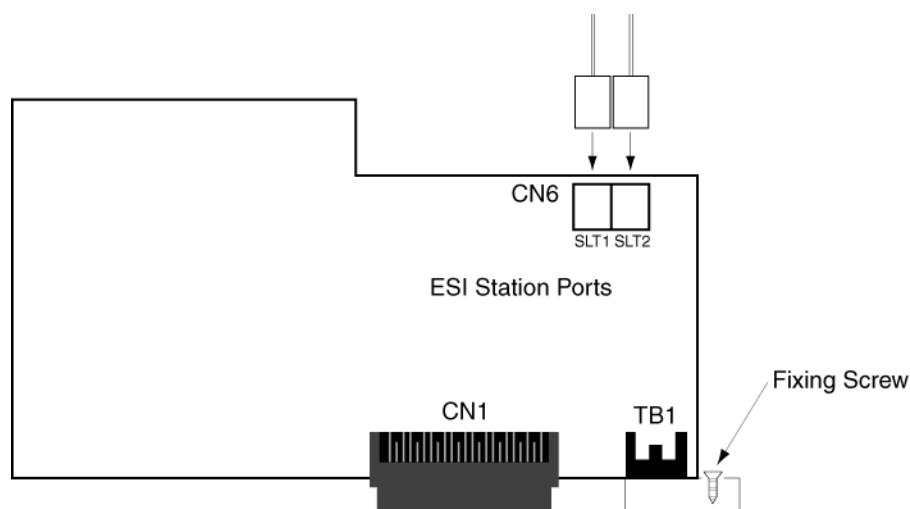

Figure 2-22: SLI(2)-B13 ETU

COI(2)-B13 ETU

The COI ETU is an interface for two analogue Central Office Trunks (exchange lines) and contains circuitry for ring detection, line reversal detection, holding, dialling and control functions. Each Loop Start trunk may be programmed as either DTMF or Decadic dialling. Two COI(2)-B13 ETUs can be installed in the system, providing a total of 6 CO/PBX trunks. These ports are arranged as follows:

Mainboard (Built-in COI) → Trunk Ports 01 to 02

COI(2)-B13 ETU (CN14) → Trunk Ports 03 to 04

COI(2)-B13 ETU (CN16) → Trunk Ports 05 to 06

To install the COI(2)-B13 ETU:

1. Ensure that the system is turned OFF.
2. Remove the cover from the KSU.
3. Carefully remove the ETU from its packaging, using a wrist strap connected to the frame ground on the KSU to avoid static discharge.
4. Using a philips head screwdriver, secure the ETU to the KSU by tightening the screw captive in the metal bracket on the ETU.
5. Run the COI cabling from the ETU to the external MDF. A single twisted-pair is required for each connection, this is not polarity sensitive. Crimp the special connector supplied to each cable pair.
6. Replace the KSU cover.
7. Turn the system ON.
8. Program the system as required, although the additional ports are automatically assigned default values.

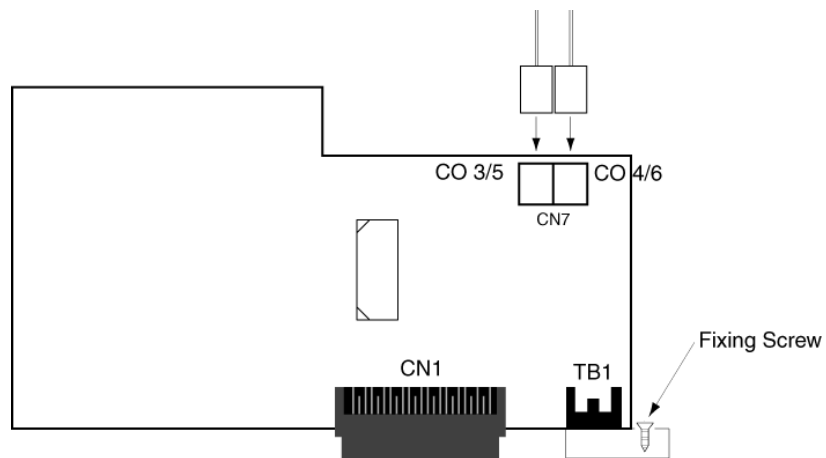

Figure 2-23: COI(2)-B13 ETU

CID(2)-B13 Unit

The CID Unit provides analogue COI trunks with incoming Caller ID indication. Three CID(2)-B13 Units can be installed in the system, one on the mainboard and one on each of the COI(2)-B13 ETUs, providing each of the 6 analogue COI trunks with Caller ID indication. This arrangement is indicated as follows:

Mainboard (Built-in COI) → Trunk Ports 01 to 02

COI(2)-B13 ETU (CN14) → Trunk Ports 03 to 04

COI(2)-B13 ETU (CN16) → Trunk Ports 05 to 06

To install the CID(2)-B13 ETU:

1. Ensure that the system is turned OFF.
2. Remove the cover from the KSU.
3. Carefully remove the Unit from its packaging, using a wrist strap connected to the frame ground on the KSU to avoid static discharge.

To install for COI Ports 1 and 2:

4. Locate connector CN18 (marked CID) on the mainboard, then position the CID Unit over it making sure that the small hole in the CID Unit is aligned with the post on the KSU. Press the unit down firmly to lock it into place and secure with the two screws supplied using a philips head screwdriver.

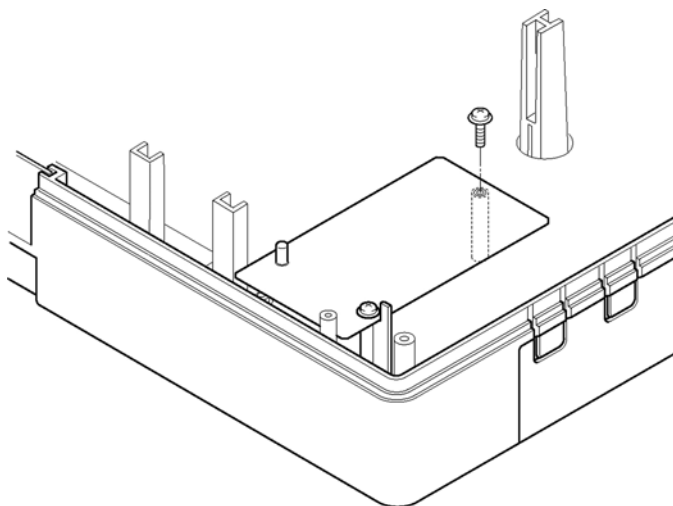

Figure 2-24: Mounting the CID(2)-B13 Unit onto the Mainboard

To install for COI Ports 3 and 4 or 5 and 6:

1. If the COI(2)-B13 ETU is already installed, remove its screw using a philips head screwdriver and then carefully remove the board from its slot.
2. Attach the three plastic stand-offs supplied to the CID Unit by pressing the large flanged end into the hole in the CID Unit. Place these onto the side of the Unit where connector CN1 is located.
3. Locate connector CN2 (marked CID) on the COI ETU, then position the CID Unit over it making sure that the stand-offs on the CID Unit are aligned with the holes in the COI ETU. Press the two boards together firmly to lock into place each standoff and the mating connectors.
4. Reinstall the COI ETU into the KSU. (Refer to *COI(2)-B13 ETU, Pg 63.*)

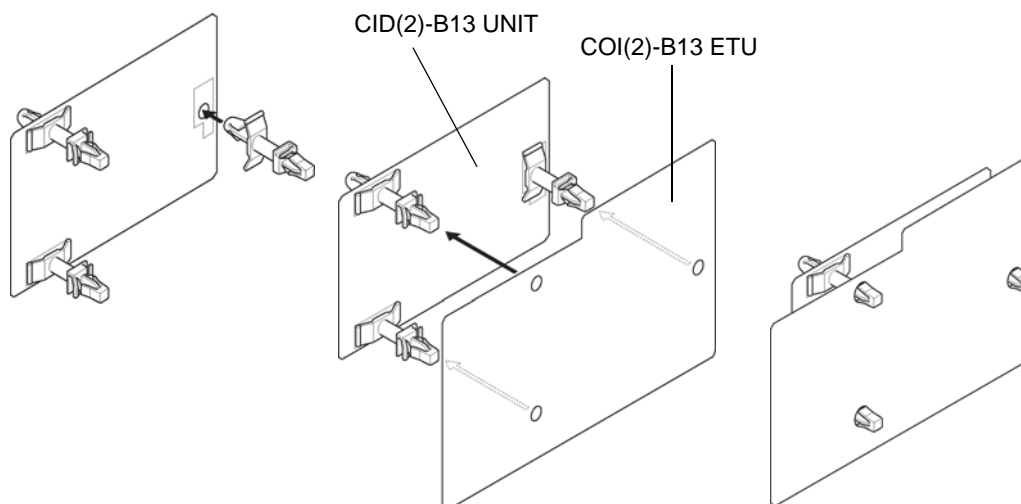

Figure 2-25: Mounting the CID(2)-B13 Unit onto the COI(2)-B13 ETU

5. Replace the KSU cover.
6. Turn the system ON.

BRT(1)-B13 ETU

The BRT ETU provides an interface for one ETSI compliant Basic Rate ISDN service. Both point-to-point and point-to-multipoint services are supported. This digital service supplies two 64 kbps channels, which can each carry a voice call. Therefore providing the system with two trunks. Two BRT(1)-B13 ETUs can be installed in the system, providing 4 BRT channels and 6 trunks in total. These ports are arranged as follows:

Mainboard (Built-in COI) → Trunk Ports 01 to 02

BRT(1)-B13 ETU (CN15) → Trunk Ports 03 to 04

BRT(1)-B13 ETU (CN17) → Trunk Ports 05 to 06

To install the BRT(1)-B13 ETU:

1. Ensure that the system is turned OFF.
2. Remove the cover from the KSU.
3. Carefully remove the ETU from its packaging, using a wrist strap connected to the frame ground on the KSU to avoid static discharge.
4. Locate connector CN15 or CN17 (marked BRT) on the mainboard and slide the ETU between the posts. Press the ETU down firmly to lock into place.
5. Using a philips head screwdriver, secure the ETU to the KSU by tightening the screw captive in the metal bracket on the ETU.
6. Run the BRT cable from the ETU to the external NT-1 (the interface box installed by the ISDN service provider). A twin twisted-pair cable is required, terminated at each end with an RJ-45 plug in a 1-1 configuration. CAT-5 or similar cable is recommended. (Refer to *Figure 2-27: BRT(1)-B13 ETU Connection Cable*, Pg 66.)
7. Replace the KSU cover.
8. Turn the system ON.
9. Program the system as required, although the additional ports are automatically assigned default values.

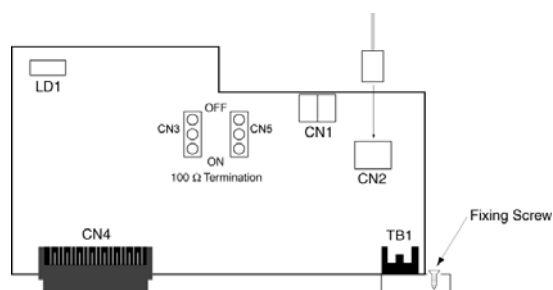

Figure 2-26: BRT(1)-B13 ETU

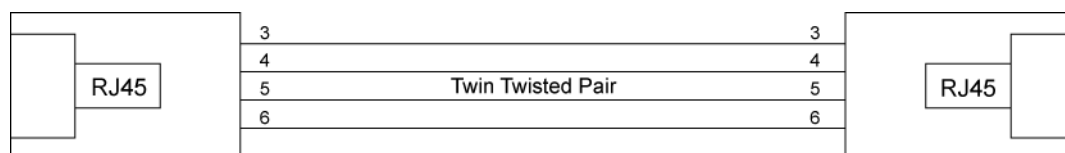

Figure 2-27: BRT(1)-B13 ETU Connection Cable

Optional ETUs

PBR-B13 ETU

The Push Button Receiver (PBR) ETU detects and translates DTMF dialling tones generated by single line telephones, faxes, modems etc., connected to the system via the SLI(2)-B13 ETU, APR-UA Unit or the FAX Port. One PBR-B13 ETU can be installed in the system, providing 4 PBR circuits.

To Install the PBR-B13 ETU:

1. Ensure that the system is turned OFF.
2. Remove the cover from the KSU.
3. Carefully remove the ETU from its packaging, using a wrist strap connected to the frame ground on the KSU to avoid static discharge.
4. Attach the plastic stand-off (supplied) to the PBR ETU by pressing the large flanged end into the hole in the lower left of the ETU. Place this onto the side of the ETU where connector CN1 is located.
5. Locate connector CN9 (marked PBR) on the mainboard, then position the PBR ETU over it making sure that the stand-off on the ETU and the post on the KSU are both properly aligned. Press the ETU down firmly to lock into place the stand-off and the mating connectors.
6. Secure the PBR ETU with the screw supplied using a philips head screwdriver.
7. Replace the KSU cover.
8. Turn the system ON.

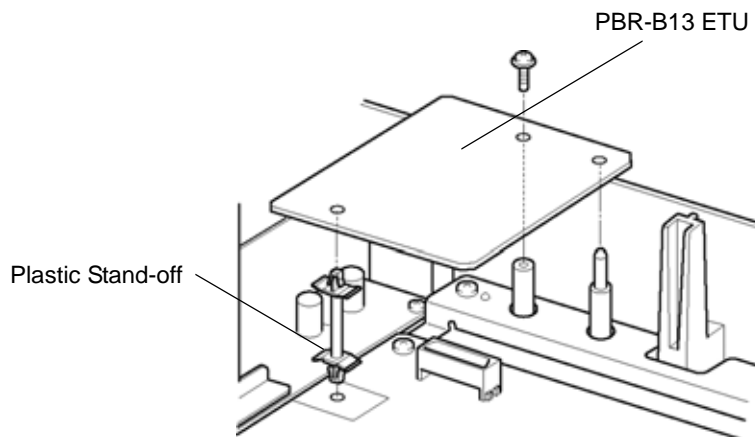

Figure 2-28: PBR-B13 ETU

MIF-B13 ETU

The MIF-B13 ETU provides one RS-232 port and additional memory to support the PC Programming and Station Message Detail Recording (SMDR) facilities. One PBR-B13 ETU can be installed in the system.

To install the MIF-B13 ETU:

1. Ensure that the system is turned OFF.
2. Remove the cover from the KSU.
3. Remove the ground place (located at the bottom of the KSU) by removing its screw located inside the KSU.

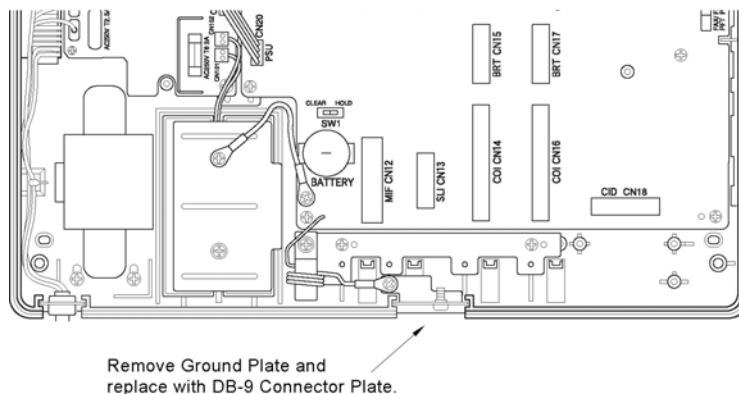

Figure 2-29: Removing the Ground Plate

4. Place the green grounding wire on top of the DB-9 plate (supplied) and tighten with the original screw.

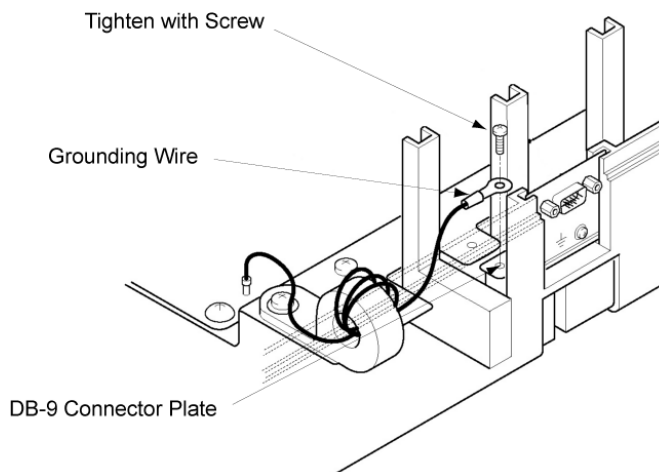

Figure 2-30: Mounting the DB-9 Plate

5. Carefully remove the ETU from its packaging, using a wrist strap connected to the frame ground on the KSU to avoid static discharge.
6. Locate connector CN12 (marked MIF) on the mainboard and slide the ETU between the posts. Press the ETU down firmly to lock into place.
7. Using a philips head screwdriver, secure the ETU to the KSU by tightening the screw captive in the metal bracket on the ETU.
8. Plug the 8-way connector on the end of the DB-9 CABLE into CN2 on the MIF ETU. Plug the male DB-9 end of the serial cable connecting to your PC or Printer into this DB-9 socket on the KSU.

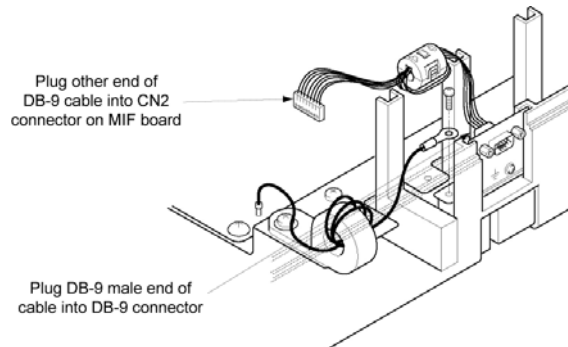

Figure 2-31: Connecting the DB-9 Cable

9. Replace the KSU cover.
10. Turn the system ON.
11. Program the system as required.

RS-232C Interface Specifications:

Baud Rate: SMDR – 1200, 2400, 4800*, 9600 bps
 PC Programming – 19200 bps (fixed)

Data Length: 8 bits
 Stop Bits: 1*, 2 bits
 Parity: None
 Flow Control: XON/XOFF
 (* = Default Setting)

RS-232C Cable Requirements:

Straight RS-232C serial cable terminated with male DB-9 connector at one end. The other end of the cable will be terminated to suit the connected equipment (i.e. printer, PC, etc.).

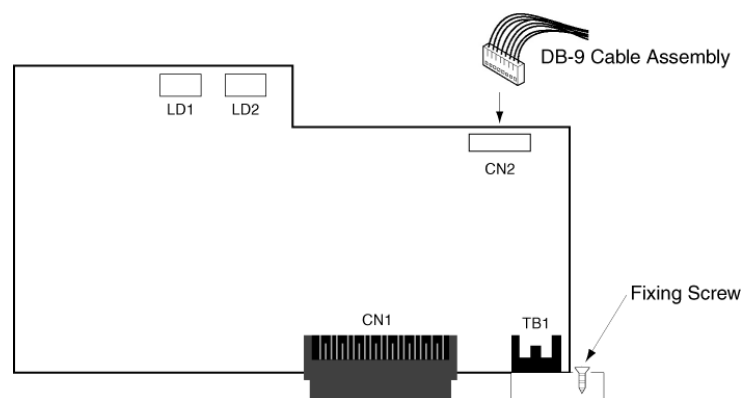

Figure 2-32: MIF-B13 ETU

DPH-B13 ETU

The Door Phone (DPH) ETU provides connection for two Door Phone units and two Door Lock Release devices. Use only the NEC DP-D-1D Door Phone Unit. A suitable third-party door lock release device must be locally supplied. One DPH-B13 ETU can be installed in the system.

To install the DPH-B13 ETU:

1. Ensure that the system is turned OFF.
2. Remove the cover from the KSU.
3. Carefully remove the ETU from its packaging, using a wrist strap connected to the frame ground on the KSU to avoid static discharge.
4. Locate connector CN5 (marked DPH) on the mainboard and slide the ETU between the posts.
5. Using a philips head screwdriver, secure the ETU to the KSU by tightening the screw captive in the metal bracket on the ETU.
6. Run the cabling for the door phones and door lock releases from the ETU to the external MDF. A single pair is required for each connection, and this is not polarity sensitive. Crimp the special connector supplied to each cable pair.
7. Replace the KSU cover.
8. Turn the system ON.
9. Program the system as required.

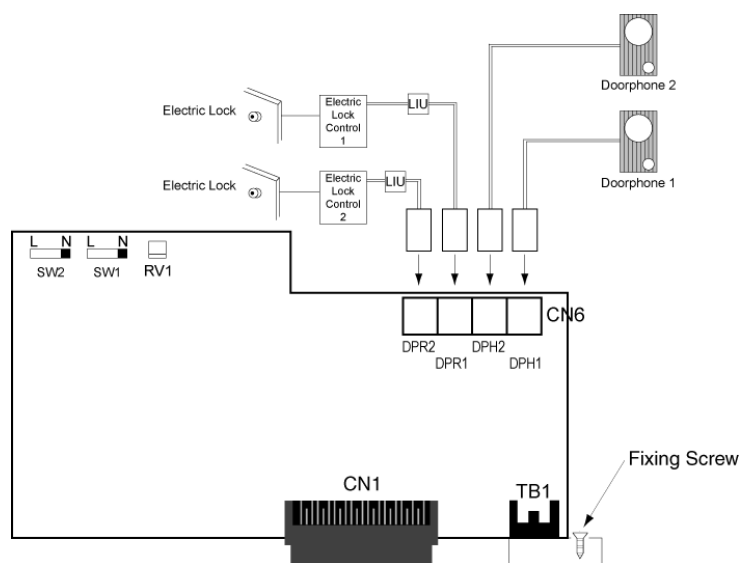

Figure 2-33: DHP-B13 ETU

Door Phones

Switches SW1, SW2 and RV1 allow the volume levels between the doorphone units and the KSU to be adjusted. Adjust these switches as required to achieve optimal door phone performance. (Refer to *Table 2-2: DPH-B13 ETU Switch Settings, Pg 71.*)

Table 2-2: DPH-B13 ETU Switch Settings

Function	Reference	Default	Settings
Volume Adjustment: Telephone to Doorphone	SW1	NORMAL	This adjustment effects DP1 & DP2. NORMAL: Normal Volume LOUD: Increased Volume
Volume Adjustment: Telephone to Doorphone	SW2	NORMAL	This adjustment effects DP1 & DP2. NORMAL: Normal Volume LOUD: Increased Volume
Balance Adjustment: Between DP1 & DP2	RV1		Turn RV1 to adjust the Sidetone of the doorphone call. Lower the Sidetone if howling occurs in either the telephone or doorphone, or if the level is uncomfortable to an MLT user during a doorphone call. If howling cannot be eliminated in this way, this may be due to the surrounding environment and switches SW1 and SW2 being set to the LOUD setting. Return SW1 and SW2 to the NORMAL setting and repeat adjustment of RV1.

When the Door Phone button is pressed, one of two tones is produced at the assigned telephones (ports 01 and 02 as default).

Connections

Wiring to each Door Phone requires a single-pair cable, to a maximum Loop Resistance of 20 Ω . Connections DPH1 and DPH2 are not polarity sensitive.

Door Lock Release

While on a Door Phone call, the telephone user can enter an Access Code to operate the associated Door Lock Release momentarily so that the caller can enter the door.

Connections

Connection between terminals DPR1, DPR2 and the door lock device is via a single pair cable, not polarity sensitive. A dry contact closure is provided to the external device.

Connection of door lock release equipment must be via a Line Isolation Unit with a Telecommunications compliance label. The Batesford Electronics Model BE-104 is an example.

TRF-B13 ETU

The Trunk Transfer (TRF) ETU allows an analogue trunk to be used as the incoming or outgoing trunk in a Call Forward External operation. Note that the outgoing trunk must be provided with Line Reversal on Answer or Line Reversal on Idle (depending on the application) by the service provider. The TRF ETU is not required however, if both trunks are ISDN. One TRF-B13 ETU can be installed in the system, providing one trunk transfer circuit.

To install the TRF-B13 ETU:

1. Ensure that the system is turned OFF.
2. Remove the cover from the KSU.
3. Carefully remove the ETU from its packaging, using a wrist strap connected to the frame ground on the KSU to avoid static discharge.
4. Locate connector CN8 (marked TRF) on the mainboard and slide the ETU between the posts. Press the ETU down firmly to lock into place.
5. Replace the KSU cover.
6. Turn the system ON.
7. Program the system as required.

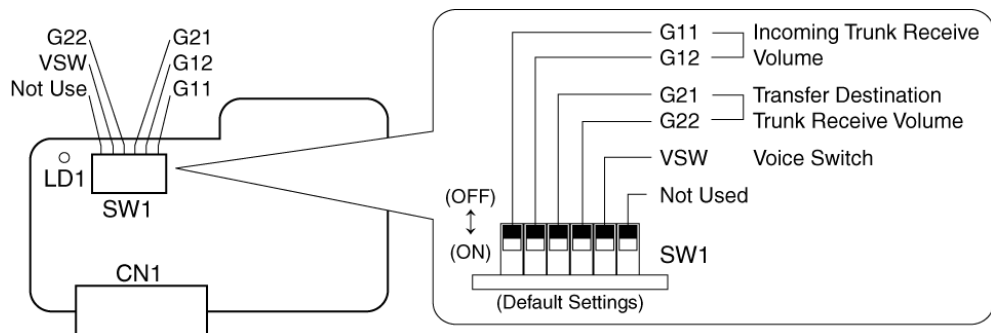

Figure 2-34: TRF-B13 ETU

Trunk Transfer Speech Volume Adjustment

Refer to *Table 2-3: TRF-B13 ETU Switch Settings, Pg 73*, and *Table 4-4: CO/PBX Line Loss Compensation, Pg 73* if speech volume during a transferred call is too low.

When operating with Auto Level Control and Voice Switches OFF, take note of the following points during transmission tests. If satisfactory settings cannot be achieved under the following conditions, operate with the Voice Switch ON.

1. If the incoming trunk receiving volume is too low, change the G11/G12 switch setting to one level higher.
2. If the transfer destination trunk receiving volume is too low, change the G21/G22 switch setting to one level higher.
3. If the incoming trunk receiving signal contains a 'booming' noise, change the G11/G12 switch setting to one level lower.
4. If the transfer destination trunk receiving signal contains a 'booming' noise, change the G21/G22 switch setting to one level lower.

CAUTION

1. Depending on line conditions, speech levels may decrease during trunk transfer.
2. Hold tones may become distorted when the Voice Switch is ON.

Table 2-3: TRF-B13 ETU Switch Settings

Item	Switch	Default	Setting
Voice Switch Usage	Voice Switch (VSW)	ON	<p>ON: Transmitter/receiver switching as in a transceiver.</p> <p>*Use same setting for destination trunk receiving volume switch and incoming trunk receiving volume switch.</p> <p>*If speech volume cannot be adjusted using the procedure below, set switch to ON.</p>
Speech Volume Control for Trunk Transfer	Incoming Trunk Receiving Volume Switch	G11:OFF G12:OFF	<ul style="list-style-type: none"> • Refer to <i>Table 4-4: CO/PBX Line Loss Compensation, Pg 73</i> for details. * Adjust transfer destination trunk and incoming trunk speech volume during a trunk transferred call. • Set receiving volume level according to line loss (in dBm) in the circuit up to the exchange line destination point.
	Outgoing Trunk Transmit Volume Switch	G21:OFF G22:OFF	

Table 4-4: CO/PBX Line Loss Compensation

Level	CO/PBX Line Resistance	Compensation Level	Incoming Trunk Receive Volume		Outgoing Trunk Transmit Volume	
			G11	G12	G21	G22
4	1281 \Rightarrow 1880 Ω (9.0 \Rightarrow 14.0 dBm)	+12 dBm	ON	ON	ON	ON
3	911 \Rightarrow 1280 Ω (6.0 \Rightarrow 9.0 dBm)	+9 dBm	ON	OFF	ON	OFF
2	551 \Rightarrow 910 Ω (3.0 \Rightarrow 6.0 dBm)	+6 dBm	OFF	ON	OFF	ON
1	<550 Ω (<3.0 dBm)	+3 dBm	OFF	OFF	OFF	OFF

VRS-B13 ETU

The Voice Recording Service (VRS) ETU provides five functions:

- Automated Attendant
- Automatic Answer
- Manual Answer
- Hold Message
- UCD Greeting Message

One VRS-B13 ETU can be installed in the system and this provides one voice channel.

To install the VRS-B13 ETU:

1. Ensure that the system is turned OFF.
2. Remove the cover from the KSU.
3. Carefully remove the ETU from its packaging, using a wrist strap connected to the frame ground on the KSU to avoid static discharge.
4. Move switch SW1 on the VRS ETU to the ON position.
5. Locate connector CN6 (marked VRS) on the mainboard and slide the ETU between the posts. Press the ETU down firmly to lock into place.
6. Replace the KSU cover.
7. Turn the system ON.
8. Program the system as required.

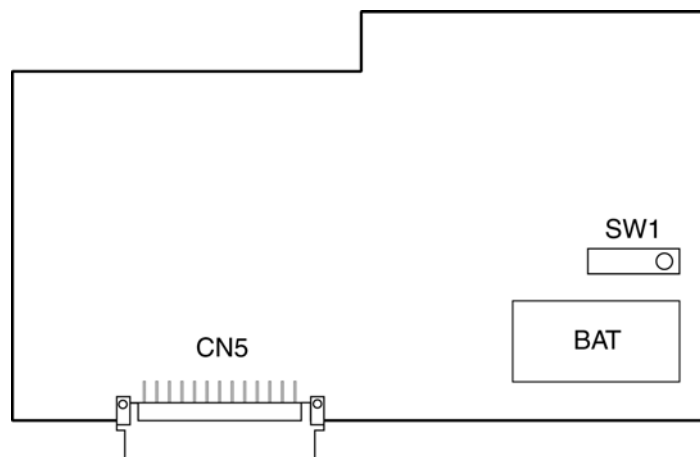

Figure 2-35: VRS-B13 ETU

VMS(2)-B13 ETU

The VMS ETU is a fully integrated digital Voice Mail Service for Xen Alpha users. It provides two primary functions:

- Voice Mail
- Automated Attendant

One VMS(2)-B13 ETU can be installed in the system providing two voice channels. This shares the same slot as the VRS-B13 ETU, hence only one of these two application cards can be installed in a system.

To install the VMS(2)-B13 ETU:

1. Ensure that the system is turned OFF.
2. Remove the cover from the KSU.
3. Carefully remove the ETU from its packaging, using a wrist strap connected to the frame ground on the KSU to avoid static discharge.
4. Locate connector CN7 (marked VMS) on the mainboard and slide the ETU between the posts. Press the ETU down firmly to lock into place.
5. Replace the KSU cover.
6. Turn the system ON.
7. Program the system as required.

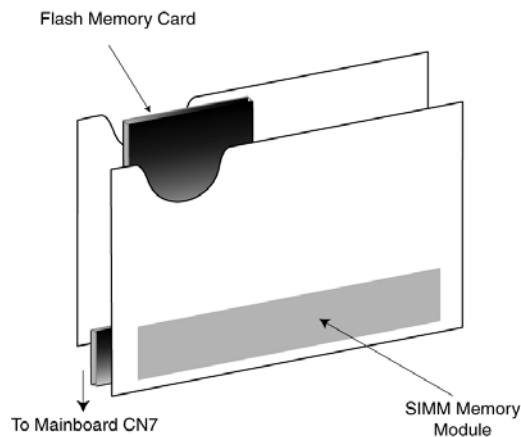

Figure 2-36: VMS(2)-B13 ETU

Note: After turning on system power or pressing the RESET button on the VMS ETU, the VMS service will be unavailable for several minutes while the VMS ETU performs its startup procedure.

Power Failure Backup

Operation in the Event of a Power Failure

In the event of a power failure, the optional built-in batteries or external batteries (locally provided) provide full backup of the service of the system for a period dependent on the system configuration and service conditions. Two Power Fail Transfer (PFT) Single Line telephone Interface Circuit are built into the KSU. The KSU connects each Single Line Telephone directly to CO/PBX line (01 and 02) to allow origination and termination of calls. (Refer to *Figure 2-37: Power Failure Backup Flowchart, Pg 76.*)

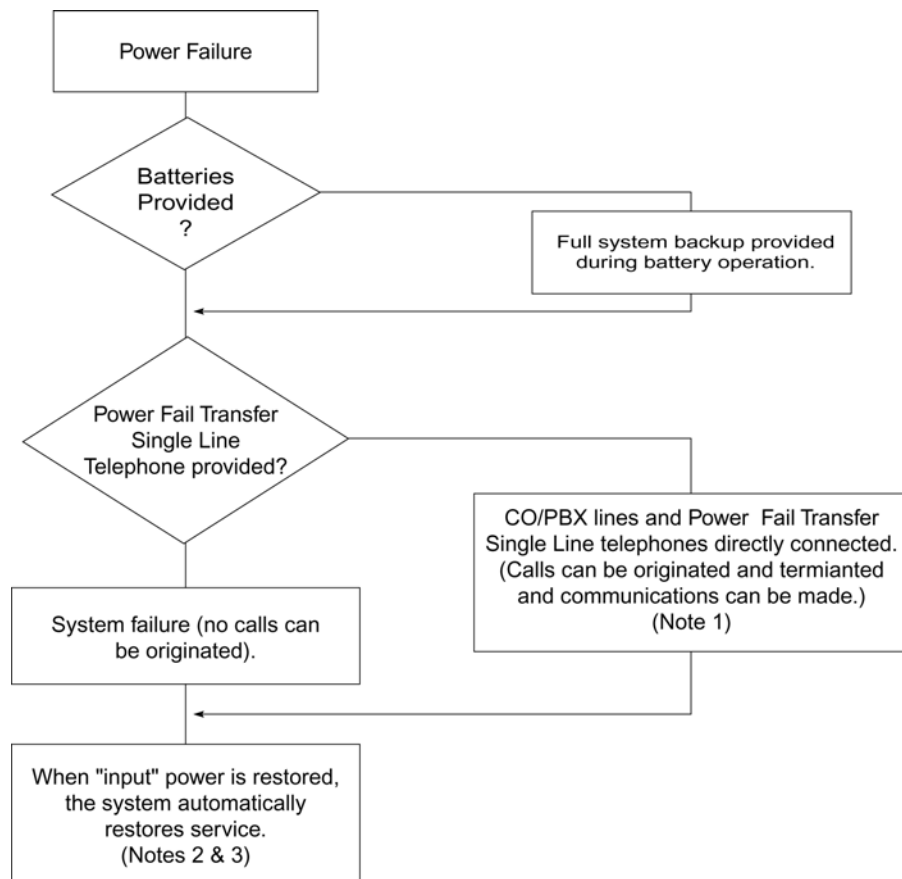

Figure 2-37: Power Failure Backup Flowchart

- Note 1:** All calls in progress are interrupted when switch over is made to connect the Power Fail Transfer Single Line Telephones directly to the CO/PBX Line 1. This occurs after backup batteries have expired.
- Note 2:** If the power switch of the KSU is in the OFF position, the system will not automatically restart service.
- Note 3:** When power is restored, calls in progress on the Power Fail telephones will not be interrupted.

Operation When Input Power is Restored

When input power is restored, the system automatically resets and restores service.

Single Line Telephone for Power Fail Transfer

A Single Line telephone can be used as a Power Fail Transfer telephone. (Refer to Power Fail telephone and Fax connection for details.)

Operating Procedure

To use the Single Line telephone for power fail transfer during a power failure, proceed as follows:

Originating:

1. Lift the handset. (Ensure that dial tone is heard.)
2. Dial the desired number.
3. Talk.

Receiving:

1. Receive ringing tone.
2. Lift the handset and answer.

 **Note:** The Single Line telephone, designated for Power Fail Transfer, must match the dialling type of the corresponding CO/PBX line (10 pps, 20 pps or DTMF) where it is connected.

General Information

Connection Requirements

The KSU is connected with each of the Multiline Terminals, Single Line telephones, optional equipment and analogue trunks by a separate twisted-pair cable through the MDF. ISDN connection requires two twisted-pair cables. (Refer to Chapter 2 for details.)

Cabling Precautions

When selecting cables and the MDF, future expansion or assignment changes should be given due consideration. Avoid running cables in the following places:

- A place exposed to wind or rain.
- A place near heat radiating equipment or where the quality of PVC covering could be affected by gases and chemicals.
- An unstable place subject to vibration.
- Close proximity to computers or radio frequency generating equipment.

Terminating Cables to Special Connectors

When installing a B614-B13, KSU, ESI(8)-B13 ETU, COI(2)-B13 ETU, DPH-B13 ETU or SLI(2)-B13 ETU, the cables must be terminated to the connectors provided in the ETU packing box. The following instructions explain this procedure.

1. Cut the two cables the same length and insert them into the connector. Ensure that each cable has been inserted all the way to the end of the cover. (Refer to *Figure 2-38: Attaching the Cables to the Connector, Pg 78.*)

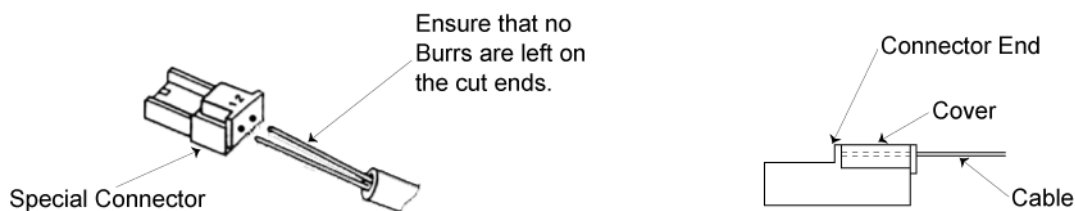

Adapter Cable		
ICT Cable	Core Diameter	Insulation Diameter
	0.40 mm	0.66 mm
	0.50 mm	0.80 mm
	0.65 mm*	1.20 mm
*Remove insulation from wire before inserting into connector.		

Figure 2-38: Attaching the Cables to the Connector

2. Lightly hold the connector with the pliers. In this case, make sure that the crimping portion is held between the lower portion of the jaws of the pliers. (Refer to *Figure 2-39: Holding the Connector with the Pliers, Pg 78.*)

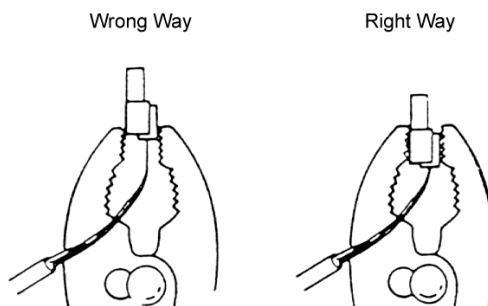

Figure 2-39: Holding the Connector with the Pliers

3. Squeeze the pliers to crimp the cables. If the cover is loose, press the cover again with the pliers. Be careful when squeezing the handles of the pliers as excessive pressure may cause damage to the connectors.
4.
 - a) After crimping the leads into the special connectors, insert them into the appropriate socket in the KSU, pushing firmly until the connector snaps securely into position.
 - b) To disconnect the plug from the socket, grasp it firmly using a pair of pliers and pull while holding the unit in place. Do not pull on the wires directly.
 - c) Do not reuse the plugs once they have been clinched as this may result in a poor connection.

Wiring to the KSU

Multiline Telephone Connection (ETW/DTU-Type)

When connecting ETW or DTU-type Multiline Terminals to the MDF, individually twisted 1-pair cabling must be used. (Refer to *Figure 2-40: ETW/DTU-Type Multiline Terminal and SLT Adapter Connection*, Pg 79.)

NOTE: Polarity is not critical as the Multiline Terminals are not polarity conscious.

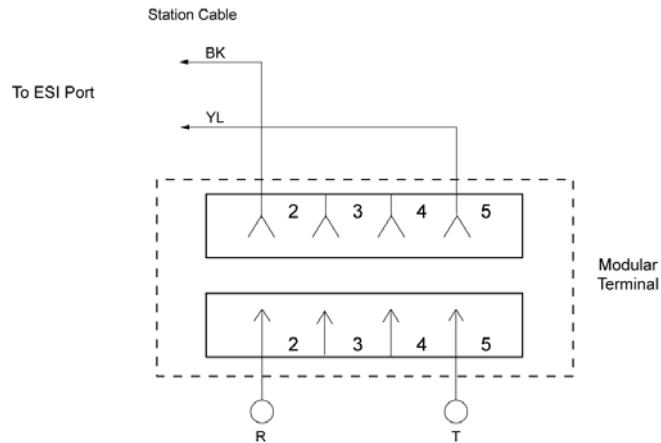

Figure 2-40: ETW/DTU-Type Multiline Terminal and SLT Adapter Connection

Multiline Telephone Connection (Dterm Series i)

When Connecting Dterm Series i Multiline Terminals to the MDF, individually twisted 1-pair cabling must be used. (Refer to *Figure 2-41: Dterm Series i Multiline Terminal Connection*, Pg 79.)

NOTE: Polarity is not critical as the Multiline Terminals are not polarity conscious.

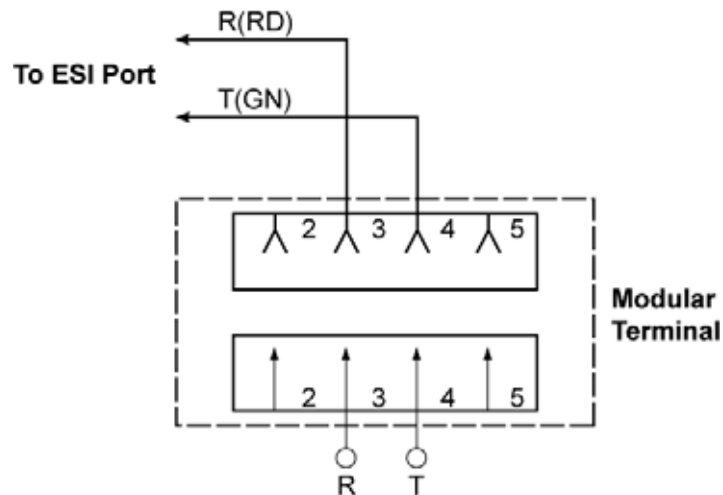

Figure 2-41: Dterm Series i Multiline Terminal Connection

Single Line Telephone Connection

DTMF or DP dialling and Single Line Telephones can be used to dial within the system. One-pair cabling is required, it is recommended that twisted pair cabling be used. (Refer to *Figure 2-42: Single Line Telephone Connection, Pg 80.*)

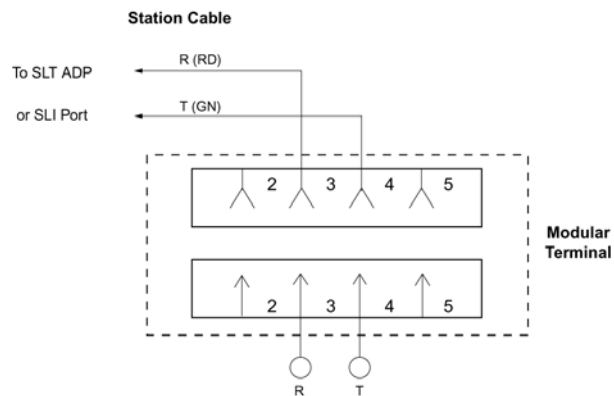

Figure 2-42: Single Line Telephone Connection

Outside Lines

CO/PBX lines are connected to this system using twisted pair wiring to cross-connect the lines from the RJ11 termination block to the system.

Do not use half-tapping or parallel connections on outside lines connected to the system.

KSU Cable Routing

All cabling should exit the KSU through the knockout panels on the right hand side. Two knockout panels are provided.

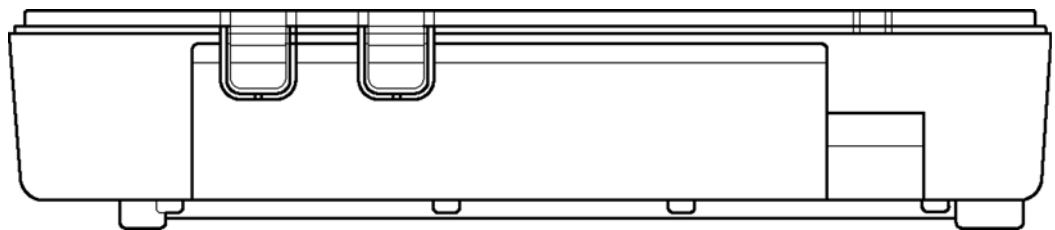

Figure 2-43: KSU Cabling Knockouts

Remove one or both of these knockouts as required, using side cutters or other suitable tool, to cut the tabs at the top of the knockout. Once the top is free, move the knockout back and forth until the tab at the bottom breaks free. Remove any burrs using a sharp knife.

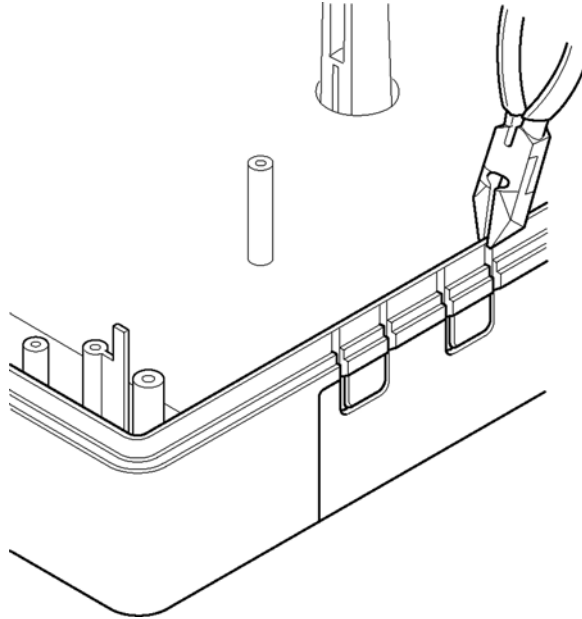

Figure 2-44: Removing the Knockout Panels in the KSU

Run the cabling from each ETU neatly around the perimeter of the mainboard against the side of the case and exit from the removed knockout(s). Secure cables to side of KSU with the self adhesive cable tie mounts and cable ties supplied (quantity 2).

This page is intentionally blank.

Installing DTB-Type Multiline Terminals

SECTION 1
GENERAL
INFORMATION

The Xen Alpha system provides a choice of two different DTB-Type Multiline telephones. This chapter describes each terminal and provides applicable installation instructions.

SECTION 2
MULTILINE
TERMINALS

DTB-16-1A (WH) TEL

This digital non-display Multiline telephone is equipped with 8 line keys (each with a two-colour LED), 8 programmable one-touch keys, a built-in speakerphone and a large LED to indicate incoming calls and messages. The angle of the handset is adjustable and it has a built-in mount facility.



Figure 3-1: DTB-16-1A (WH) TEL Multiline Telephone

DTB-16D-1A (WH) TEL

This digital Multiline Terminal is equipped with 8 line keys (each with a two-colour LED), 8 programmable one-touch keys, a built-in speakerphone and a large LED to indicate incoming calls and messages. The angle of the handset is adjustable and it has a built-in wall mount facility.

This telephone is also equipped with a 2-line, 16-character, plus symbols, Liquid Crystal Display (LCD).

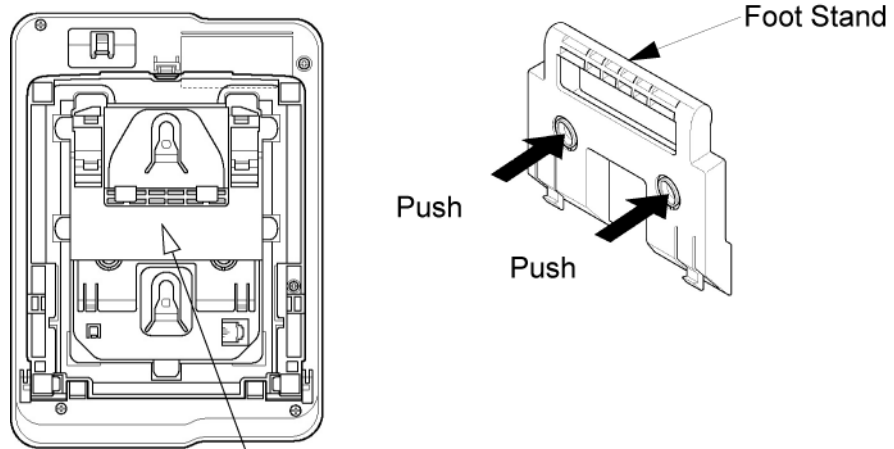

Figure 3-2: DTB-16D-1A (WH) TEL Multiline Telephone

SECTION 3
WALL
MOUNTING

The DTB-16-1A (WH) TEL and DTB-16D-1A (WH) TEL can be mounted to a wall.

1. Locate the stoppers under the height adjustment stand on the bottom of the telephone. You will need to lift the adjustment stand to expose the foot stand holding the stoppers. Remove the two plastic stoppers from the foot stand by firmly pushing on them.



Lift the adjustment stand to expose the foot stand.

2. Remove the hanger (located on the bottom of the telephone). Insert the hanger into the holes as indicated in the above diagram.

Remove hanger from bottom of telephone.

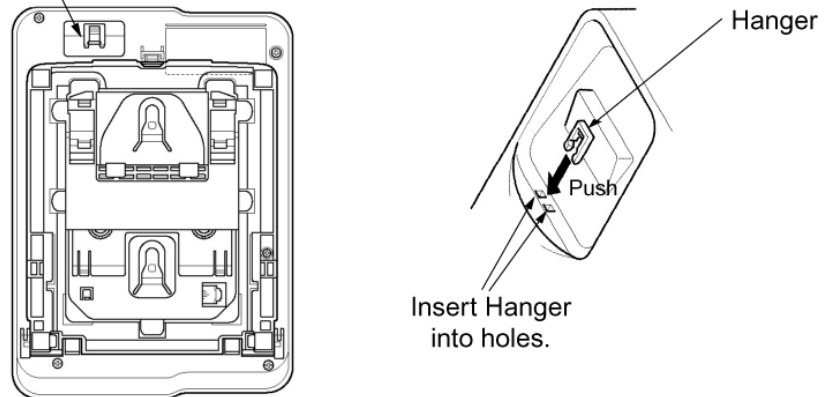

3. Use the wall mounting template (provided) to mark the screw positions on the wall.

4. Insert one end of the telephone line cord into the RJ-11 jack. Route the cord inside the height adjustment stand as indicated in the diagram. The cord can be wrapped more than once inside the height adjustment stand to shorten the length of cord. The cord can exit either the top of the telephone or the side, depending on the most convenient location of the RJ-11 wall jack.

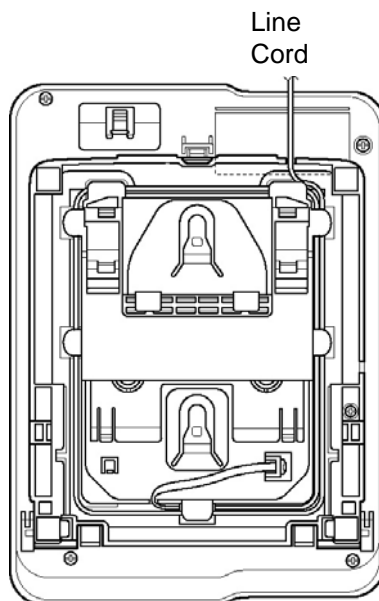

5. Using a philips head screwdriver, insert the flat head wood screw (provided) into the stopper and fasten to the wall.

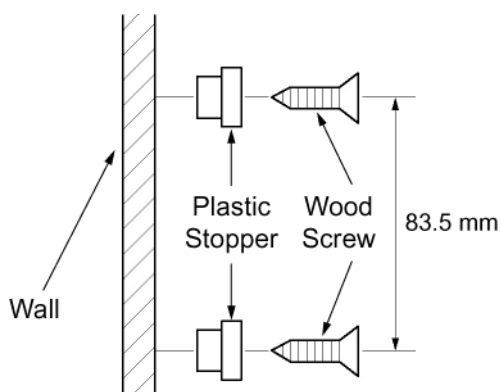

6. To hang the telephone on the wall, place the grooves (located on the bottom of the telephone) over the plastic stopper, which has been fastened to the wall. If the telephone is difficult to mount, you may want to loosen the screws holding the stopper.

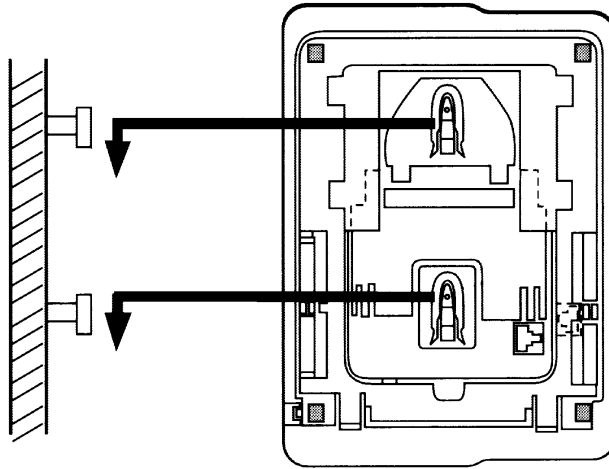

7. Insert the other end of the telephone line cord into an RJ-11 jack.

Wall Mounting Template

Use this template to mark the location of the screws on the wall.

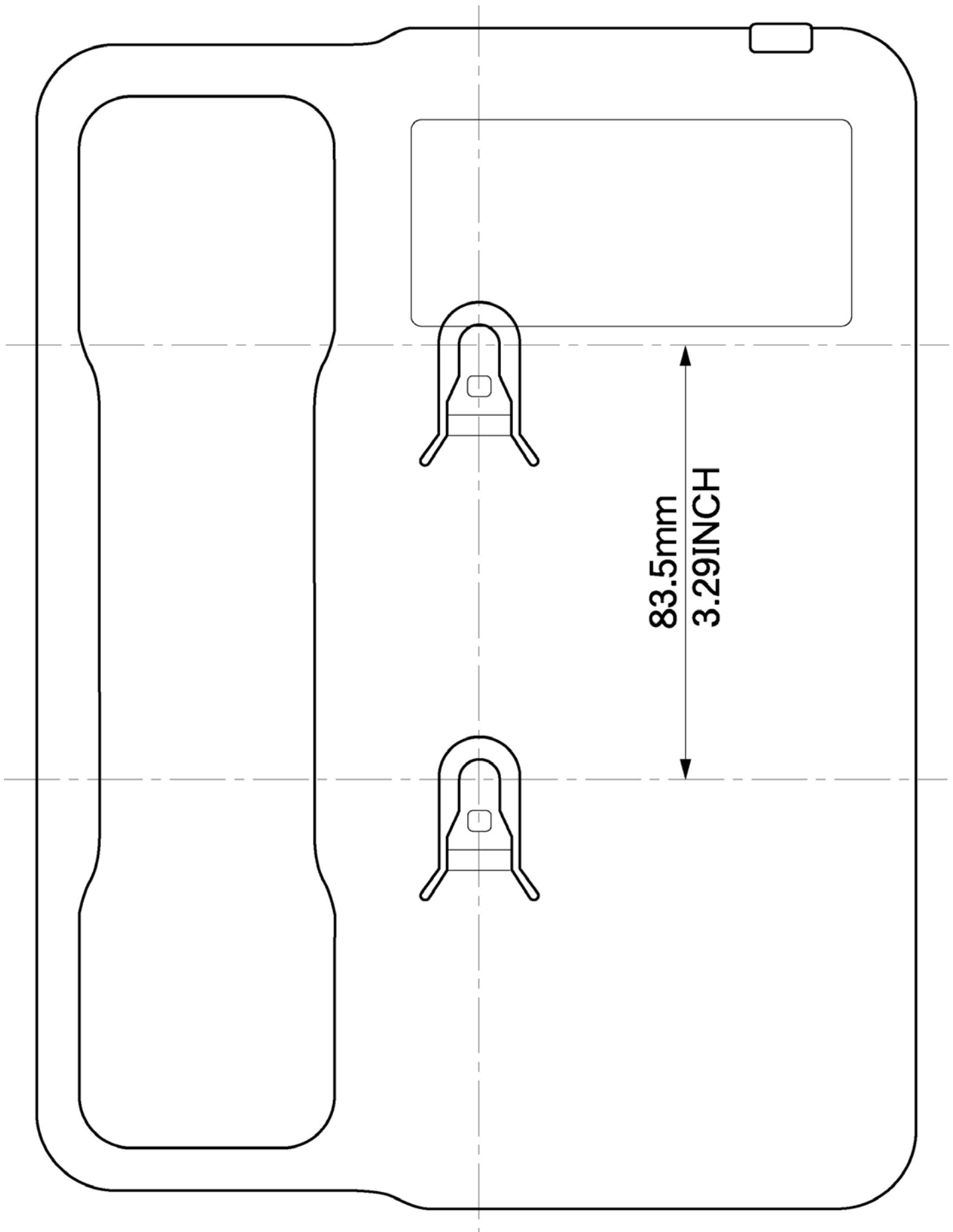

Installing Dterm Series i Multiline Terminals

SECTION 1 GENERAL INFORMATION

The Xen Alpha system supports *D^{term}* Series i Multiline telephones which provide several different Multiline Terminals. This chapter describes each terminal provides instructions for attaching the terminals to the system and for wall mounting.

SECTION 2 MULTILINE TERMINALS

2.1 DTR-2DT-1A() TEL

This digital non-display Multiline Terminal has two programmable line keys (each with a 2-colour LED), eight function keys, a built-in speakerphone and a large LED to indicate incoming calls and messages.

This telephone has a built-in data port that is available for analogue devices. Each telephone requires a digital port.

- ⓘ The DTR-2DT-1A() TEL does not support adapters.



Figure 4-1: DTR-2DT-1A() TEL

2.2 DTR-8D-1A() TEL

This digital Multiline Terminal has eight programmable line keys (each with the 2-colour LED), a built-in speakerphone, headset jack, a Large LED to indicate incoming calls and messages, and compatibility with AD(A)-R(), AP(A)-R(), AP(R)-R(), or CT(U)-R() Unit.

This terminal also has a 3-line, 24-character, adjustable Liquid Crystal Display (LCD) and four softkeys.



Figure 4-2: DTR-8D-1A() TEL Multiline Terminal

2.3 DTR-16D-1A() TEL

This digital Multiline Terminal has 16 programmable line keys (each with a 2-colour LED), a built-in speakerphone, headset jack, a large LED to indicate incoming calls and messages, and compatibility with AD(A)-R(), AP(A)-R(), AP(R)-R(), or CT(U)-R().

This terminal also has a 3-line, 24-character, adjustable Liquid Crystal Display (LCD) and four softkeys.



Figure 4-3: DTR-16D-1A() TEL Multiline Terminal

2.4 DTR-32D-1A() TEL

This digital Multiline Terminal has 16 programmable line keys (each with a 2-colour LED), 16 one-touch keys, a built-in speakerphone, headset jack, a large LED to indicate incoming calls and messages, and compatibility with AD(A)-R(), AP(A)-R(), AP(R)-R(), or CT(U)-R().

This terminal also has a 3-line, 24-character, adjustable Liquid Crystal Display (LCD) and four softkeys.

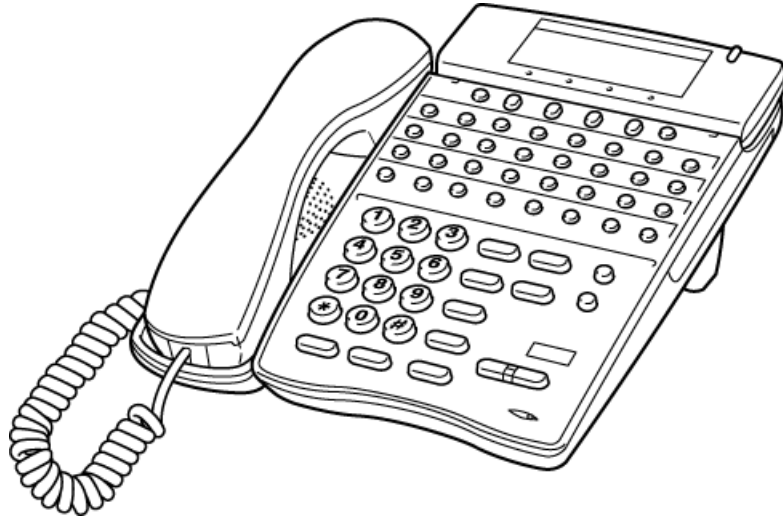

Figure 4-4: DTR-32D-1A() TEL Multiline Terminal

SECTION 3
CONNECTING A
DTERM SERIES I
MULTILINE
TERMINAL

These instructions for connecting a Multiline Terminal to the system apply to all of the *D^{term}* Series i Multiline Terminals (DTR).

1. Plug the telephone cord into the modular jack on the bottom side of the Multiline Terminal. The handset is also attached to the bottom side of the Multiline Terminal.

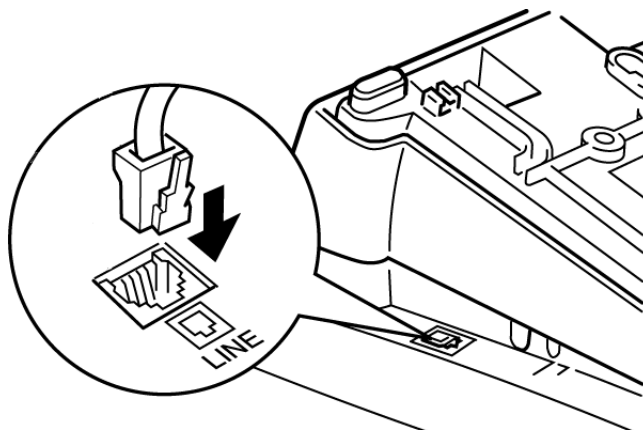

Figure 4-5: Connecting a Multiline Terminal to the System

2. Lead the telephone and handset cords through the appropriate grooves.

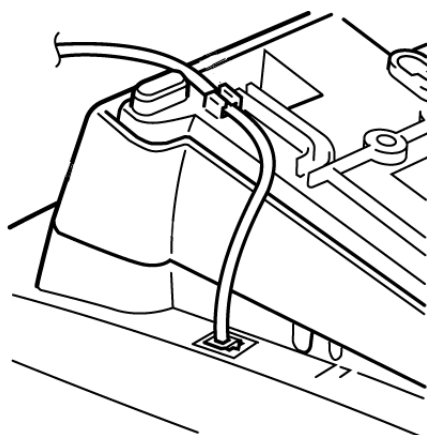

Figure 4-6: Leading Line Cords on a Multiline Terminal

SECTION 4
ADJUSTING THE
LCD ON A
MULTILINE
TERMINAL

D^{term} Series i display Multiline Terminals have an adjustable Liquid Crystal Display (LCD). The LCD can be adjusted by pulling up or pushing down as desired.

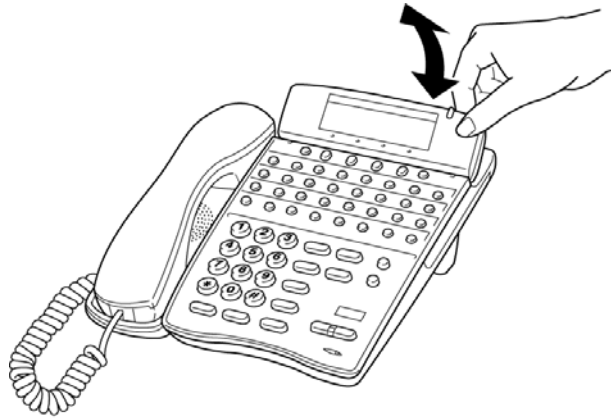

Figure 4-7: Adjusting the LCD on a Multiline Terminal

SECTION 5 INSTALLING LINE CARDS AND PLASTIC PANELS

5.1 Installing the Line Card and Plastic Panel

Line key designations are entered on the line card that is then placed on the telephone to provide a quick reference of key designations. The line cards can be changed as necessary. The plastic panel is placed on top of the line card to hold it in place.

1. Place the line card over the keys on the Multiline Terminal.

ⓘ If replacing an existing plastic panel or line card refer to *Section 9: Removing the Plastic Panel on page 1-95*.

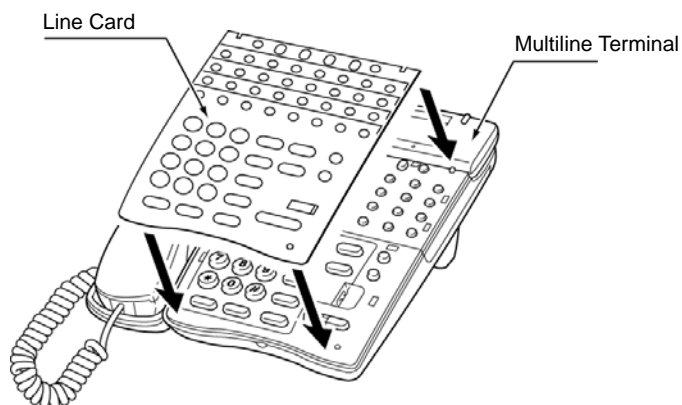

Figure 4-8: Installing the Line Card on a Dterm Series i Multiline Terminal

2. Place the plastic panel over the line card and push the corners of the plastic panel until they click into place.

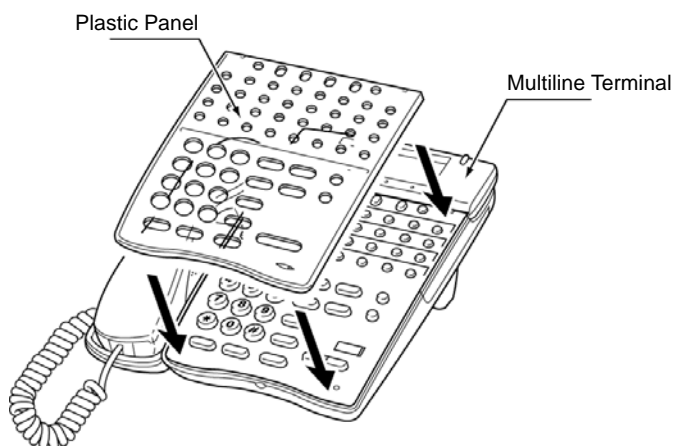

Figure 4-9: Installing the Plastic Panel on a Dterm Series i Multiline Terminal

5.2 Removing the Plastic Panel

Lift up on the plastic panel as illustrated in *Figure 4-10: Removing the Plastic Panel from the Multiline Terminal* and remove the plastic panel from the telephone.

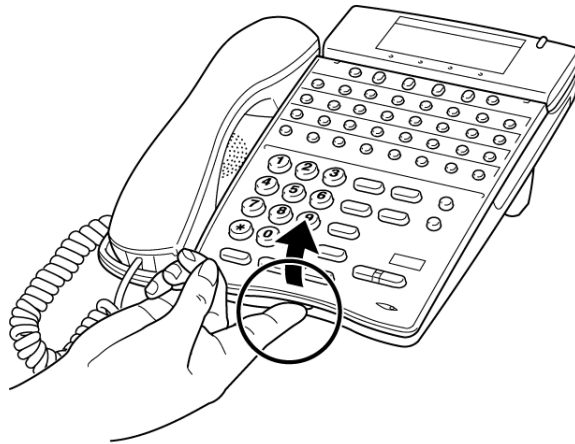

Figure 4-10: Removing the Plastic Panel from the Multiline Terminal

SECTION 6 INSTALLING A DIRECTORY CARD ON A MULTILINE TERMINAL

A directory card can be attached to *D^{term}* Series i Multiline Terminals. The directory card can be used to record often dialed numbers or other important information.

1. After recording the information on the lined insert, reinsert it between the plastic panels of the directory card. Attach the directory card to the directory card holder as illustrated in *Figure 4-11: Attaching Directory Card to Directory Card Holder*. Note that the open end slides into to the directory card holder.

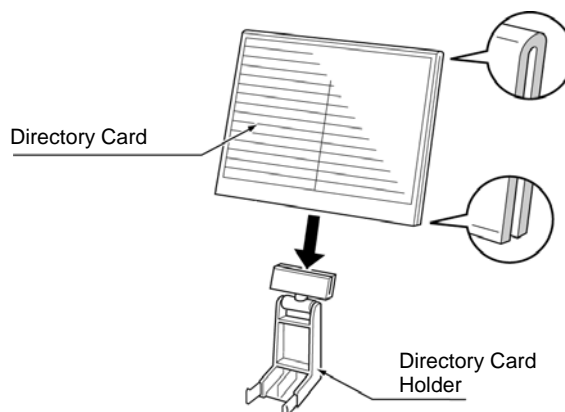

Figure 4-11: Attaching Directory Card to Directory Card Holder

2. Locate the two grooves on the top of the telephone as illustrated in *Figure 4-12: Attaching Directory Card Holder to the Multiline Terminal*. Push the directory card holder into the grooves on the Multiline Terminal until they snap into place.
 - 🔧 To remove the directory card, pinch the two sides of the directory card holder inward until the tabs release and pull the holder out of the grooves.

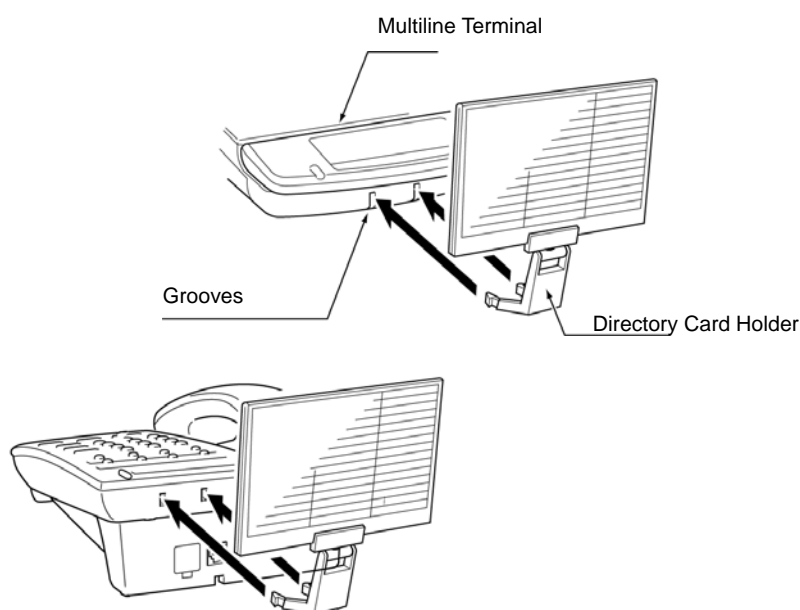

Figure 4-12: Attaching Directory Card Holder to the Multiline Terminal

SECTION 7 INSTALLING A BUTTON SET ON A MULTILINE TERMINAL

The BS()-R() Unit button set can be changed on a Multiline Terminal to accommodate other languages, special markings etc.

1. Remove the plastic cover. (Refer to *Section 9: Removing the Plastic Panel on page 1-95.*)
2. Remove the existing button pad by pulling up on the tab and lifting the button pad away from the telephone.

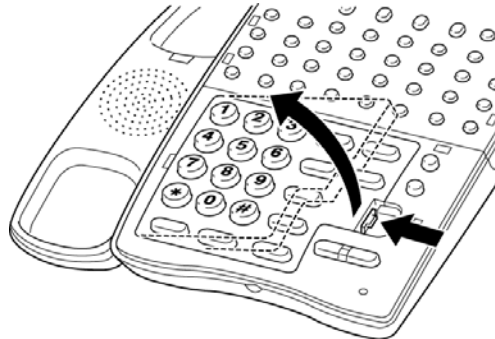

Figure 4-13: Removing the Button Set from a Multiline Terminal

3. Insert the new button set by sliding it into the grooves located on the inside of the telephone, then press down on the button set to snap it into place.

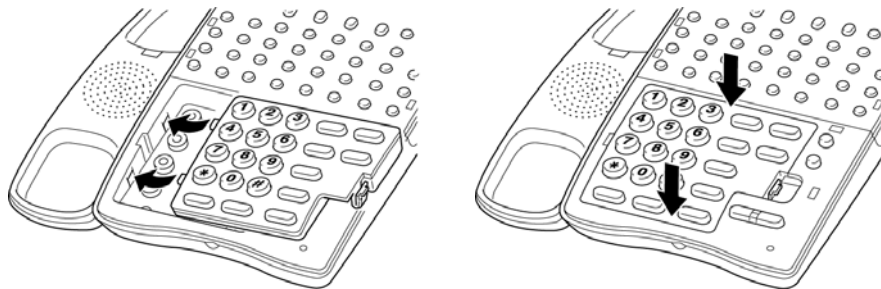

Figure 4-14: Inserting a New Button Set into a Multiline Terminal

4. Insert the line card and plastic panel on the Multiline Terminal.

SECTION 8 ADJUSTING THE HEIGHT ON A MULTILINE TERMINAL

The base plate on the *D^{term}* Series i Multiline Terminal is hinged to allow the height of the terminal to be raised or lowered.

1. Turn the Multiline Terminal upside down and locate the tabs (marked **A**).

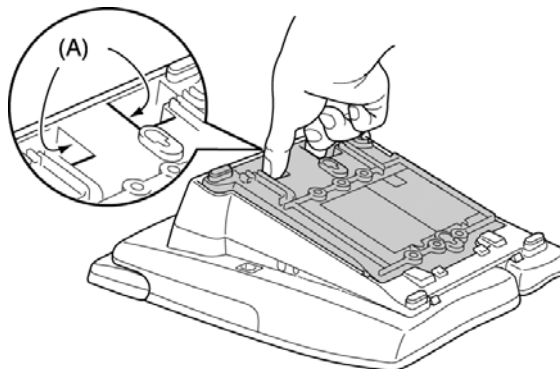

Figure 4-15: Locating the Adjustment Tabs on the Multiline Terminal

2. Grasp in the middle of the hollow spaces at the top and pull up until the retaining tabs click to raise the base plate. Refer to *Figure 4-16: Raising the Height on the Dterm Series i Multiline Terminal*.

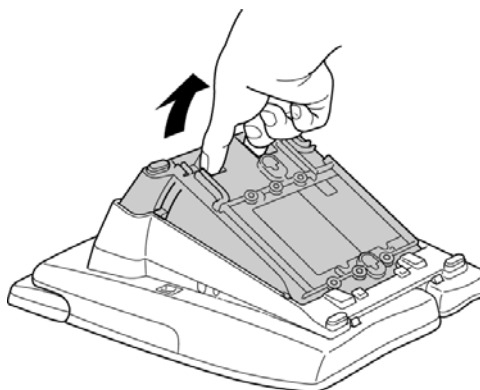

Figure 4-16: Raising the Height on the Dterm Series i Multiline Terminal

3. Once the height been adjusted, the line cord can be adjusted by pulling the line cord through the groove in the bottom of the Multiline Terminal.
4. To lower the base plate on the Multiline Terminal, push on the adjustment tabs on the side of the stand and push the base plate downward.

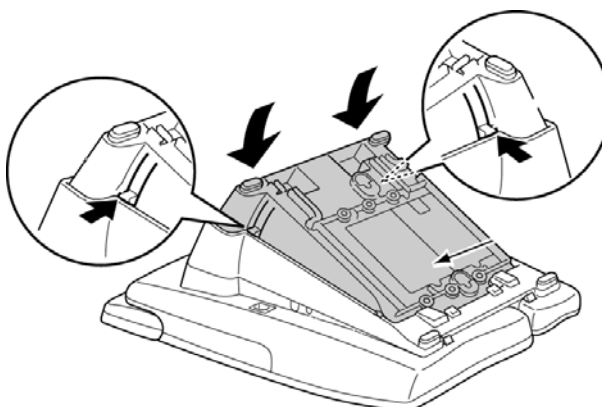

Figure 4-17: Lowering the Base Plate on the Multiline Terminal

SECTION 9
REMOVING OR
INSTALLING THE
BASE PLATE ON
A MULTILINE
TERMINAL

D^{term} Series i telephones come equipped with a base cover.

9.1 Removing the Base Plate

1. Extend the base plate to its fullest height.
2. Press the tabs as illustrated in *Figure 4-18: Removing Base Plate*, and slide the base cover in the direction of the arrows until it clicks.

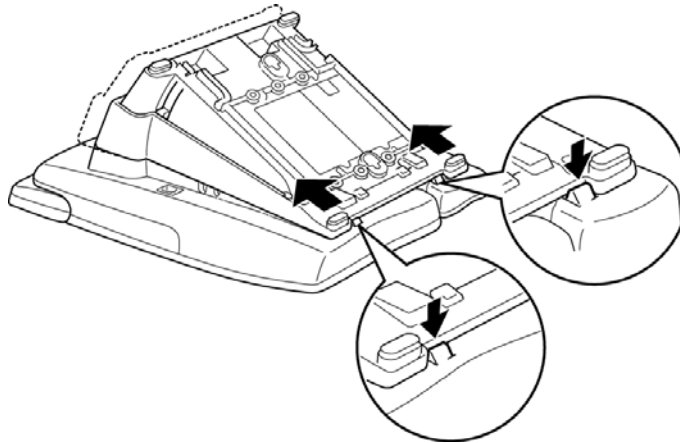

Figure 4-18: Removing Base Plate

9.2 Installing the Base Plate

1. Line up the four tabs on the base cover with their corresponding slots on the telephone as illustrated in *Section 9: Installing Base Plate on page 1-99*.
2. Slide the cover in the direction of the arrows until it clicks in place. Refer to *Section 9: Installing Base Plate on page 1-99*.

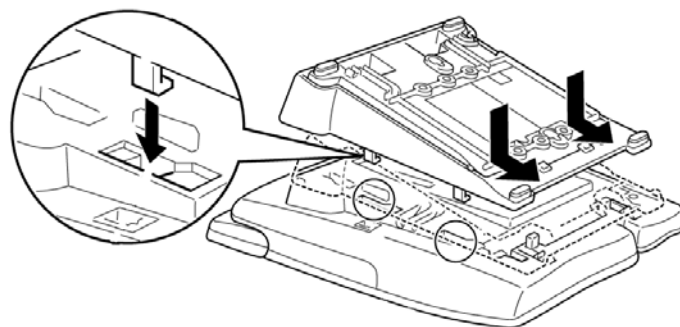

Figure 4-19: Installing Base Plate

There are two methods for wall mounting a *D^{term}* Series i Multiline Telephone; using the base cover and using a wall mount unit. A wall mount unit must be used if adapters have been installed on the Multiline Telephone.

10.1 Wall Mounting a Multiline Terminal using the Base Plate

10.1.1 Adjusting the Hanger Hook

1. Remove the hook from the unit.

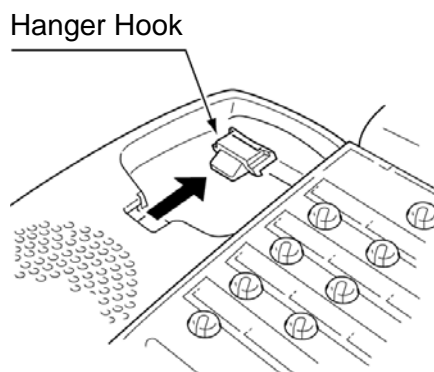

Figure 4-20: Removing the Hanger Hook on a Multiline Telephone

2. Turn the hook with the tab toward the top.
3. Slide the hook on until it glides into position forming the hanger hook for the handset.

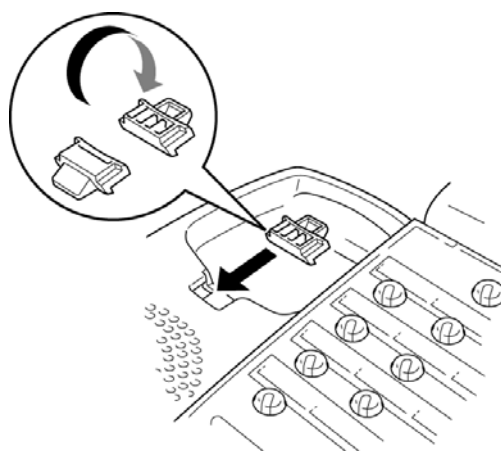

Figure 4-21: Sliding the Hanger Hook into Position

10.1.2 Wall Mounting the Telephone

1. Raise and remove the base cover from the telephone. Refer to *Section 9 Removing or Installing the Base Plate on a Multiline Terminal*.
2. Remove cutout shown in *Figure 4-22: Removing the Cutout* with nippers.

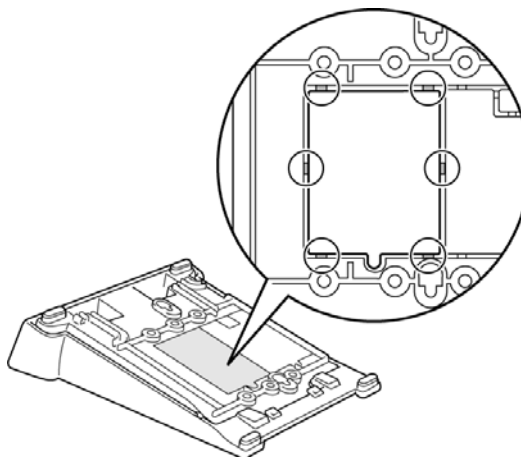

Figure 4-22: Removing the Cutout

3. Plug line cord in the wall receptacle. Leave about 8 inches of cord and bundle the rest as shown in *Figure 4-23: Bundling the Line Cord*.

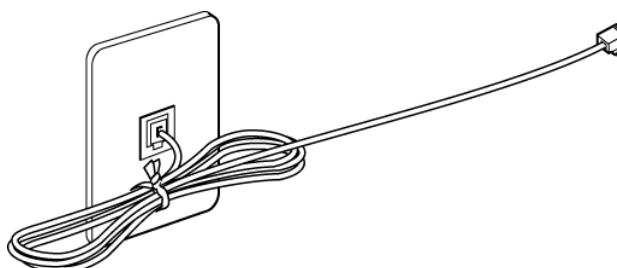

Figure 4-23: Bundling the Line Cord

4. Turn the base cover upside down, feed the line cord through the cutout and attach it to the wall using six screws as shown in *Figure 4-24: Wall Mounting the Base Plate*.

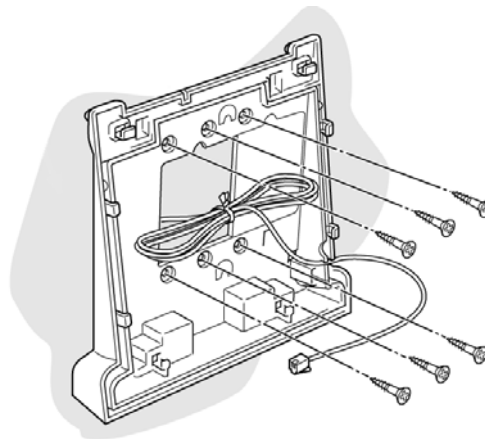

Figure 4-24: Wall Mounting the Base Plate

5. Install the telephone over the four tabs on the base cover, and push down until it clicks in place.

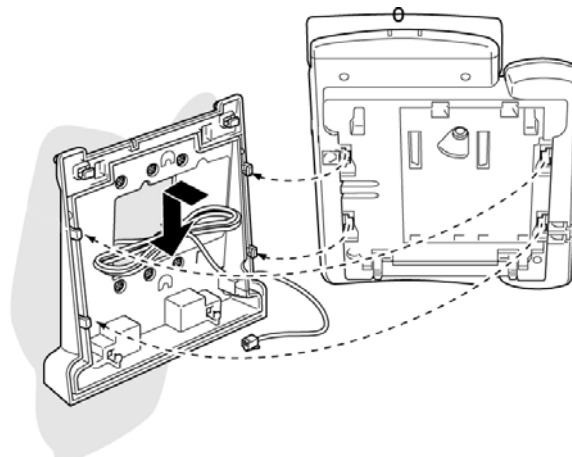

Figure 4-25: Installing the Telephone

6. Plug the line cord into the telephone as illustrated in *Figure 4-26: Plugging in Line Cord*.

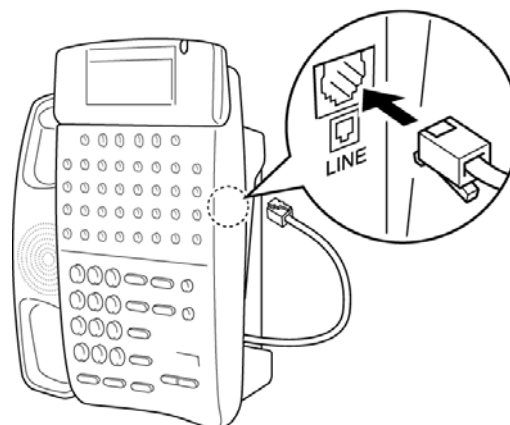

Figure 4-26: Plugging in Line Cord

7. Push spare line cord behind the telephone as shown in *Figure 4-27: Hiding Excess Cord*.

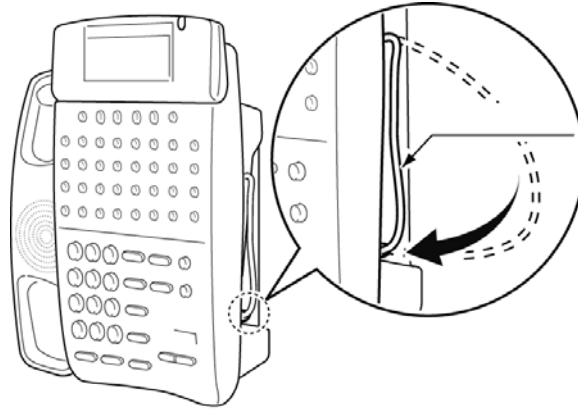

Figure 4-27: Hiding Excess Cord

10.2 Removing the Wall Mounted Telephone from the Base Plate.

To remove the telephone, press the tabs at the bottom as shown in *Figure 4-28: Removing the Telephone*, and push up on the Telephone until it comes loose.

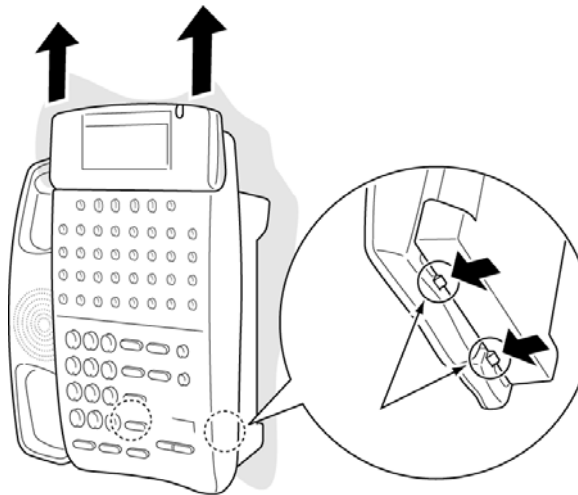

Figure 4-28: Removing the Telephone

10.2.1 Wall Mounting the Base Plate on a Switch Box

1. Locate the screw holes on the base cover and hang the cover over the screws on the switch box as illustrated in *Figure 4-29: Wall Mounting Base Plate on Switch Box*.

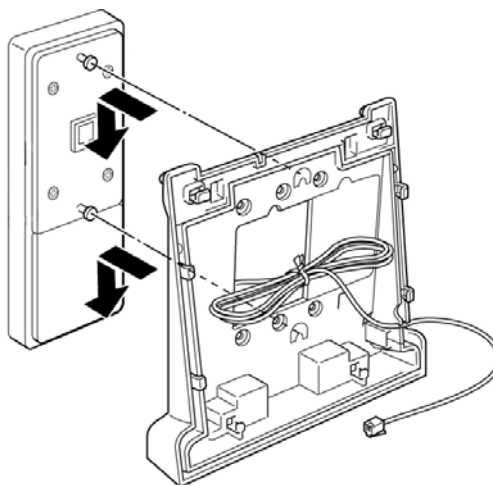

Figure 4-29: Wall Mounting Base Plate on Switch Box

2. Hang the telephone on the base cover.

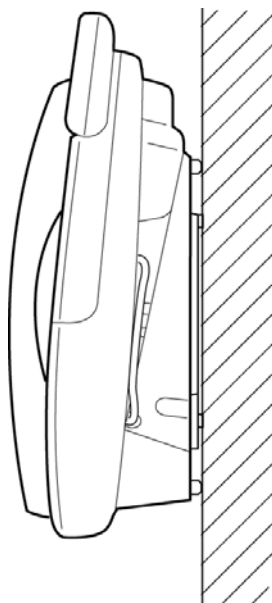

Figure 4-30: Wall Mounted Telephone

10.3 Wall Mounting a Multiline Terminal using the Wall Mount Unit (WM-R() Unit)

This Wall Mount Unit is used to mount any *D^{term}* Series i telephone (except the DTR-2DT-1A() TEL) to the wall. This unit connects to the back side of the telephone.

When adapters are installed, the telephone must be mounted on the wall using the WM-R() Unit.

1. Plug line cord in the wall receptacle. Leave about 200mm of cord and bundle the rest as shown in *Figure 4-23: Bundling the Line Cord*.

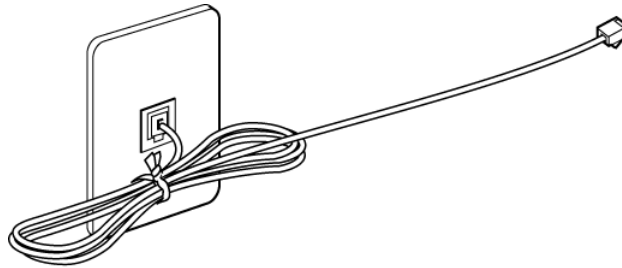

Figure 4-31: Bundling the Line Cord

2. Feed the line cord through the opening in the wall mount unit as illustrated in *Figure 4-32: Attaching the Wall Mount Unit to the Wall*.
3. Attach the WM-R() Unit using six screws.

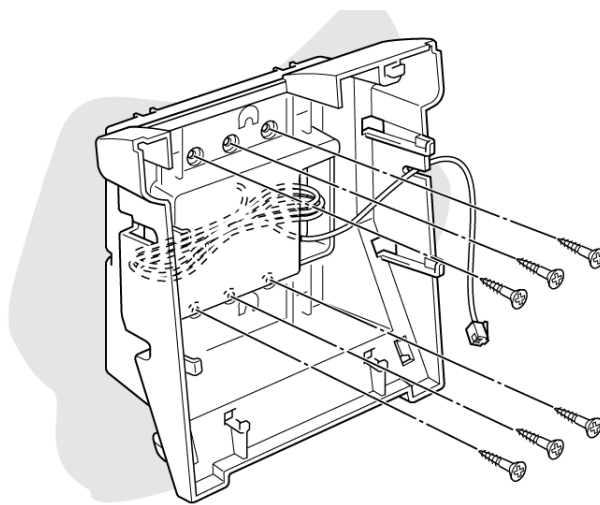

Figure 4-32: Attaching the Wall Mount Unit to the Wall

4. Install the telephone over the four tabs on the base cover, and push down until it clicks in place as illustrated in *Figure 4-33: Attaching the Multiline Telephone to the Wall Mount Unit*.

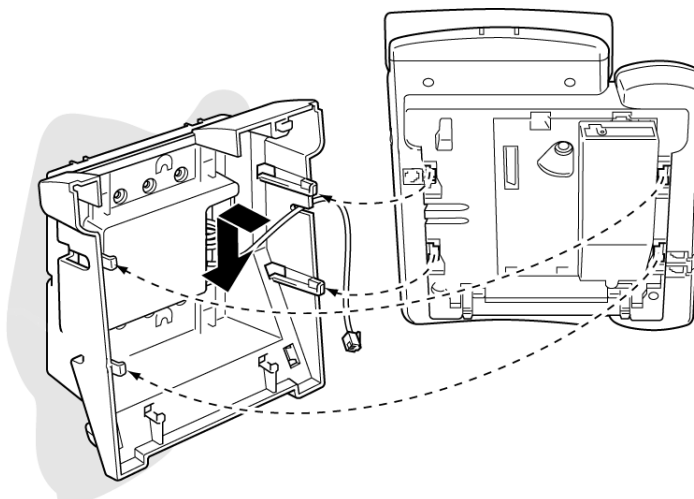

Figure 4-33: Attaching the Multiline Telephone to the Wall Mount Unit

5. Plug the line cord into the telephone as illustrated in *Figure 4-34: Plugging in Line Cord*.

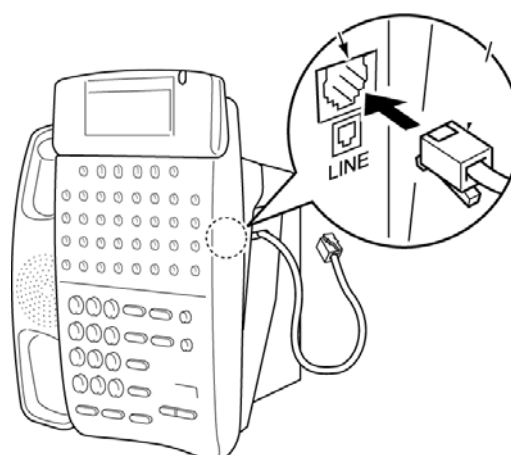

Figure 4-34: Plugging in Line Cord

6. Push spare line cord behind the telephone as shown in *Figure 4-35: Hiding Excess Cord Behind the Wall Mount Unit.*

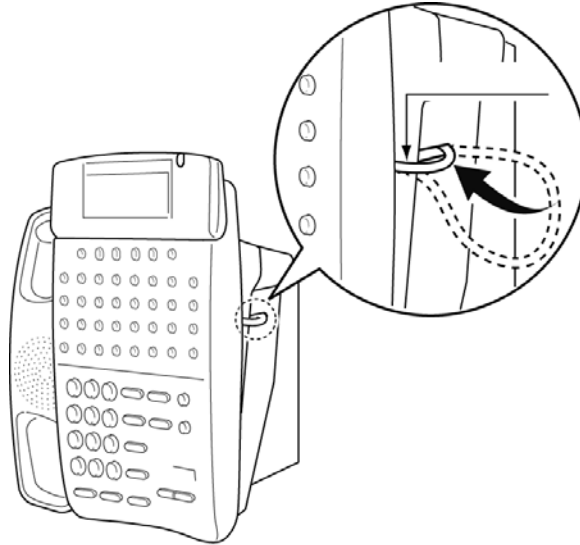

Figure 4-35: Hiding Excess Cord Behind the Wall Mount Unit

10.3.1 Removing the Wall Mounted Telephone from the Wall Mount Unit

To remove the telephone, press the tabs at the bottom as shown in *Figure 4-28: Removing the Telephone*, and push up on the Telephone until it comes loose.

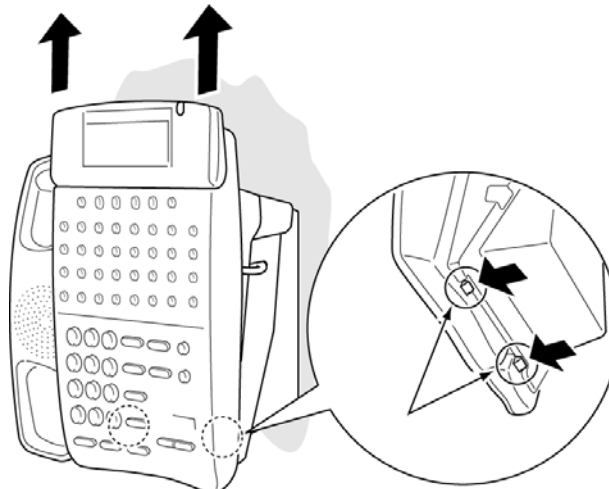

Figure 4-36: Removing the Telephone from the Wall Mount Unit

10.3.2 Mounting the Wall Mount Unit on a Switch Box

1. Locate the screw holes on the wall mount unit and hang the cover over the screws on the switch box as illustrated in *Figure 4-37: Mounting Wall Mount Unit on the Switch Box*.

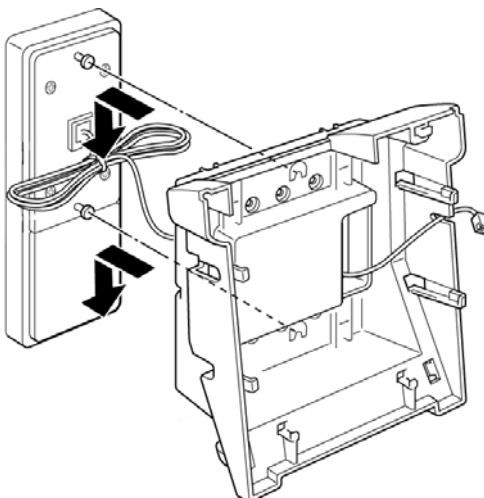

Figure 4-37: Mounting Wall Mount Unit on the Switch Box

2. Hang the telephone on the base cover.

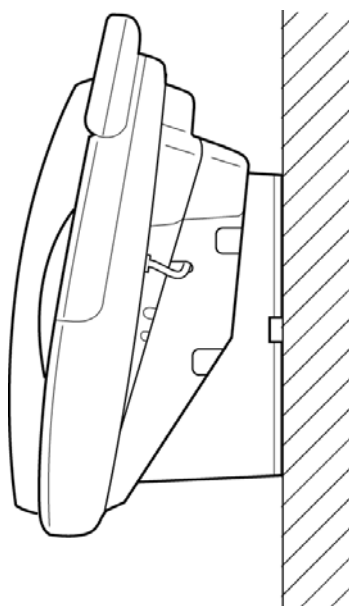

Figure 4-38: Wall Mounted Telephone

Installing Dterm Series i Optional Equipment

SECTION 1 GENERAL INFORMATION

The Xen Alpha system with *D^{term}* Series i Multiline Terminals provide several adapters that allow peripheral equipment to be attached to them. This optional equipment enhances the Xen Alpha system and can be purchased separately as a customer's business grows. Each *D^{term}* Series i Multiline Terminal can have up to two adapters installed at the same time (except the DTR-2DT-1A() TEL).

This chapter describes each adapter and provides applicable installation instructions.

SECTION 2 PREPARING FOR ADAPTER INSTALLATION

To prepare the *D^{term}* Series i Multiline Terminal for adapter installation:

1. Unplug the telephone cord from the terminal.

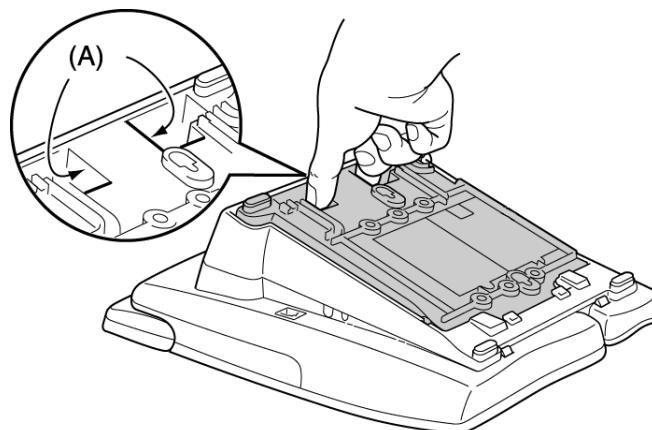

Figure 5-1: Locating the Adjustment Tabs on the Multiline Terminal

2. Grasp in the middle of the hollow spaces at the top and pull up until the retaining tabs click to raise the base plate. Refer to *Figure 5-2: Raising the Base Plate*.

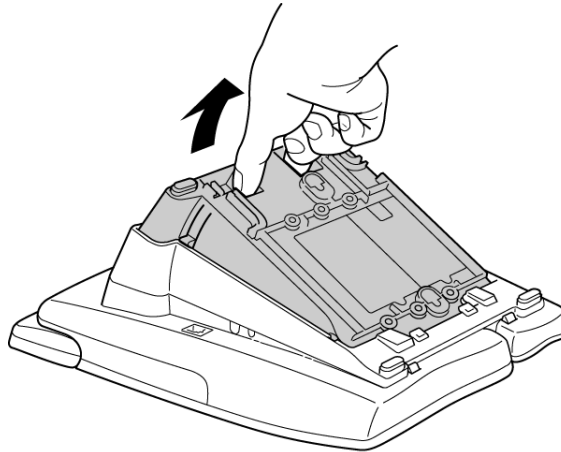

Figure 5-2: Raising the Base Plate

3. Press down on the tabs indicated in *Figure 5-3: Removing the Multiline Terminal Base Plate*, and push forward on the base plate to remove it.

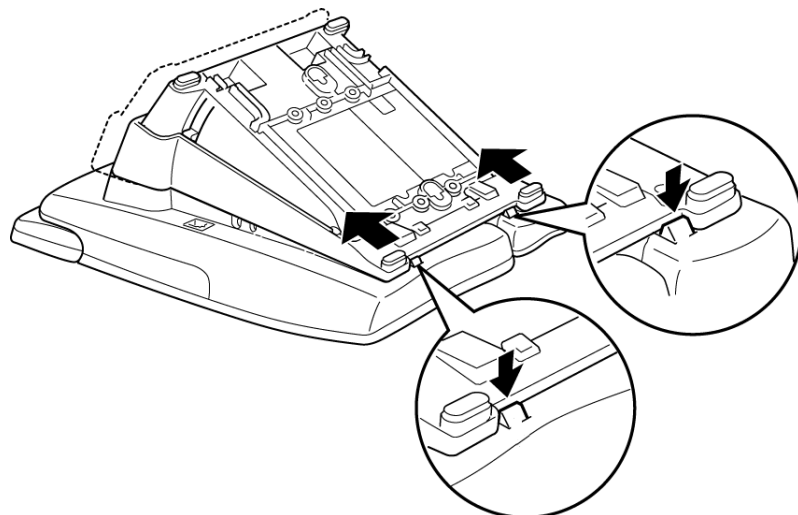

Figure 5-3: Removing the Multiline Terminal Base Plate

4. When an adapter is installed for the first time in a terminal, the base cover on the Multiline Terminal must be modified. Two adapters can be installed in the Multiline Terminal, and two separate cutouts are provided. Remove the applicable cutout/cutouts on the bottom of the base plate with nippers. When only one adapter is being installed and it needs an ACA-U() Unit for power, remove only the right cutout as shown in *Figure 5-4: Modifying Base Plate for Adapter Installation*.

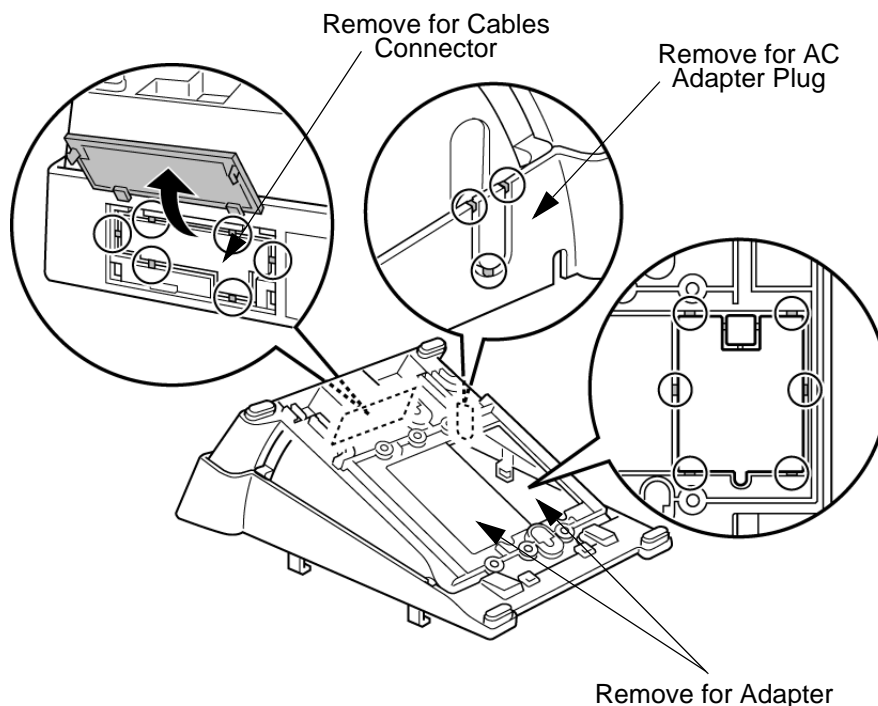

Figure 5-4: Modifying Base Plate for Adapter Installation

SECTION 3 INSTALLING ADAPTERS

3.1 ACA-U() Unit (AC Adapter)

This unit provides power to ancillary devices. The ACA-U() Unit must be connected to an adapter that is installed on a Multiline Terminal. When more than one adapter is installed on a Multiline Terminal, only one ACA-U() Unit is necessary.

The power requirements for the ACA-U() Unit are:

- ⓘ Input: 240V AC, 50 Hz
- ⓘ Output: 24V DC, 400 mA
- ⓘ Polarity: \ominus ————— \oplus

3.1.1 Connecting the ACA-U() Unit

1. Unplug the ACA-U() Unit from the AC outlet. (*Failing to do this can damage the unit and/or the Multiline Terminal.*)
2. Prepare Multiline Terminal for adapter installation. Refer to *Section 9: Preparing for Adapter Installation* on page 1-109.
3. Locate the plug on the ancillary device that is connected to the bottom of the Multiline Terminal and plug in the AC Adapter.

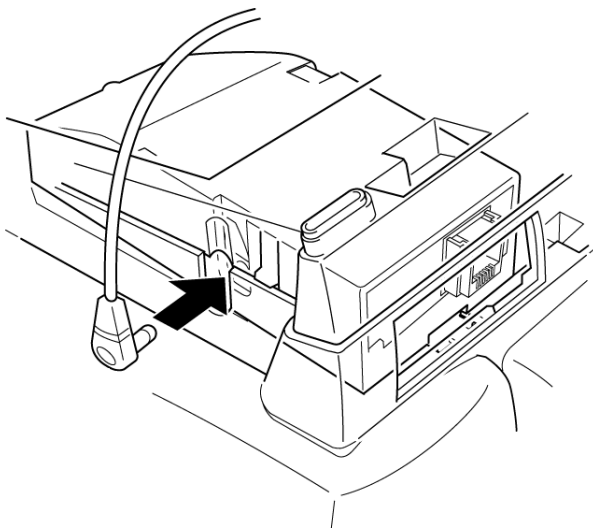

Figure 5-5: Connecting the AC Adapter to an Installed Adapter

3.2 AD(A)-R() Unit (Ancillary Device Adapter)

This Ancillary Device Adapter, shown on *Figure 5-6: AD(A)-R() Unit*, allows connection of a tape recorder to all D^{term} Series i Multiline Terminals except the DTR-2DT-1A() TEL.

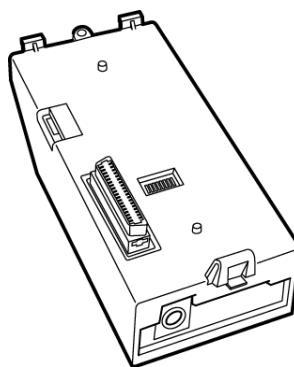

Figure 5-6: AD(A)-R() Unit

Figure 5-7: Connecting a Multiline Terminal to a Recording Device using an AD(A)-R() Unit (Example) illustrates how a terminal with an AD(A)-R() Unit is connected to the ESI(8)-U() ETU and to the recording device.

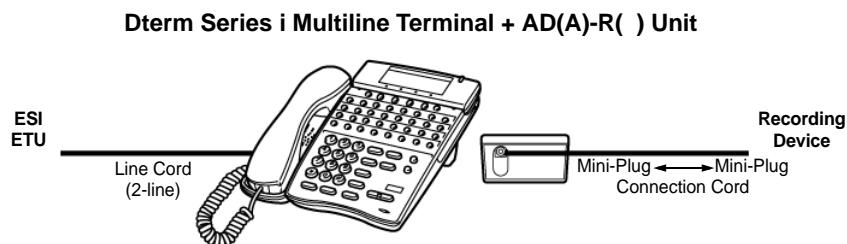

Figure 5-7: Connecting a Multiline Terminal to a Recording Device using an AD(A)-R() Unit (Example)

When installing the AD(A)-R() Unit, first connect the cables to the AD(A)-R() Unit, second set the dip switches and then install the AD(A)-R() Unit on the Multiline Terminal.

3.2.1 Connecting Cables to the AD(A)-R() Unit

The first step in installing the AD(A)-R() Unit is to connect the cables between the recording device and the AD(A)-R() Unit.

Cable terminal connectors are located on the side of the AD(A)-R() Unit. Cables should be connected on this unit **before** installing the unit on the Multiline Terminal.

Cables can be connected to determine whether or not pause control is provided for the recording.

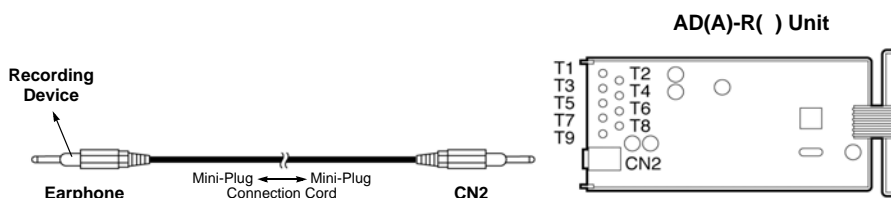

Figure 5-8: AD(A)-R() Unit Connection without Pause Control

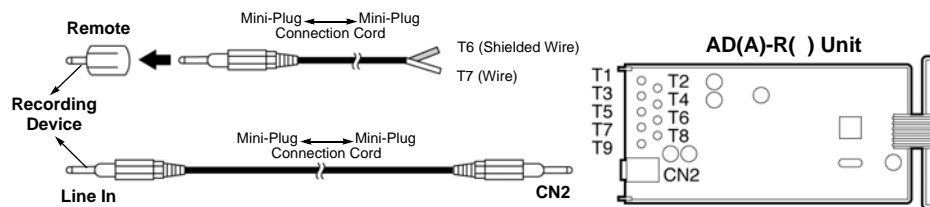

Figure 5-9: AD(A)-R() Unit Connection with Pause Control

To connect the cables:

1. Cut off the plug on one end of the cable.
2. Remove the screw as illustrated in *Figure 5-10: Removing AD(A)-R() Unit Cover* and open the unit cover.

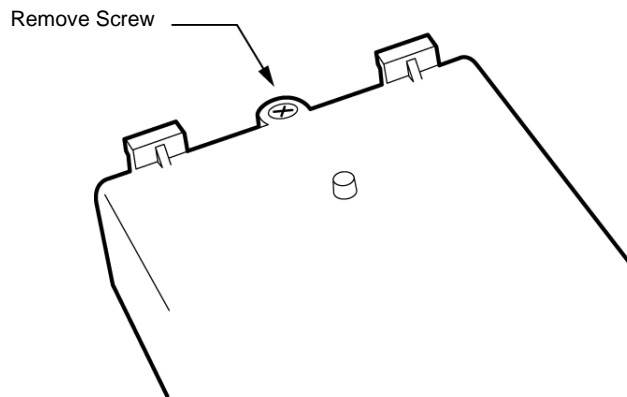

Figure 5-10: Removing AD(A)-R() Unit Cover

3. Locate the adapter terminals on the unit.
4. Remove the cap on the adapter terminal to expose the metal receptacle. Push the cable in the applicable receptacle, and replace the cap. Line up the slot on the cap with the slot on the metal receptacle to ensure proper contact. (Refer to *Section 9: Attaching Cables to the AD(A)-R() Unit* on page 1-114).

Attach the cables to the AD(A)-R() Unit according to *Table 5-1: AD(A)-R() Unit Cable Connections*.

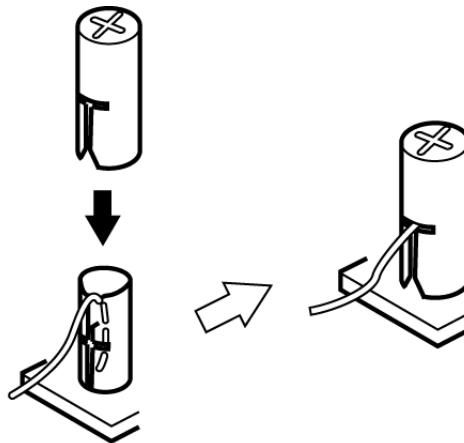

Figure 5-11: Attaching Cables to the AD(A)-R() Unit

Table 5-1: AD(A)-R() Unit Cable Connections

Terminal Number	Cables to Connect	Terminal Specifications
T1	When warning tone is not being sent from the recorder, connect wire pair input from tone generator to T1:T2. The warning tones from the generator are sent to T1:T2 on a dedicated wire pair while the speech path is sent from the AD(A)-R() on T3:T4 over a separate wire pair to the recorder.	Input Terminal: T1 and T2 are enabled for tone generating device when switches SW1-3 and SW1-4 are OFF. (When switches SW1- 3 and SW1-4 are ON, a humming sound may be recorded due to impedance mismatch.)
T2		Input Impedance on T1 and T2: 100K <Symbol>W Input Level on T1 and T2: -15 dB ~ 40 dB
T3:T4	Connect recorder device wire pair speech input to T3:T4. When the recorder used supplies a warning tone, this tone may also be sent over the T3:T4 wire pair back to the terminal.	Input/Output Terminal: Refer to dip switch settings in <i>Table 5-2: AD(A)-R() Unit Switch Settings</i> .
T5	Connect the bare end of the control cable.	When a Multiline Terminal is idle, this contact is closed. When the Multiline Terminal goes off-hook (using the handset, headset, or speakerphone), this contact is open. When recording device owner's manual specifies start on open circuit, connect T5 and T6.
T6	Connect the shielded end of the control cable.	Provides common connection for control cable.
T7	Connect the bare end of the control cable.	When the Multiline Terminal is idle, this contact is open. When the Multiline Terminal is busy (using the handset, headset, or speakerphone), this contact is closed. When recording device owner's manual specifies start on closed circuit, connect T6 and T7.
T8	Unused	
T9		

NOTES:

- ❑ When recording in handsfree (half-duplex) mode using the built-in speakerphone, the record warning tone may not be audible to the far-end party.
- ❑ The transmit recording level is lower than the receiving voice level for intercom calls; the transmit recording level for CO calls is normal.
- ❑ Depending on the recording device(s), separate cables may be required for the warning tone and speech path. In this case, connect the warning tone cables to input terminals T1 and T2 on the AD(A)-R() Unit (T3 and T4 are used as the recording device input).
- ❑ When remote control of the recorder is necessary, the record start/stop control is provided by connecting to T5 (or T7) and T6 on the AD(A)-R() Unit. (Connecting to T5 or T7 is determined by the specifications of the recording device.)
- ❑ When a warning Tone is provided from the recording equipment, it should be input via T3 and T4 on AD(A)-R() Unit. Do not use T1 and T2 to input Beep Tone.
- ❑ Conversations cannot be recorded from terminals connected to an AD(A)-R() Unit.

5. Insulate the end of the cable that needs to be shielded with insulating tape.
6. Feed the installed cable through the cable access port, located on the back of the unit, as illustrated in *Section 9: AD(A)-R() Unit Cable Access Port* on page 1-116.

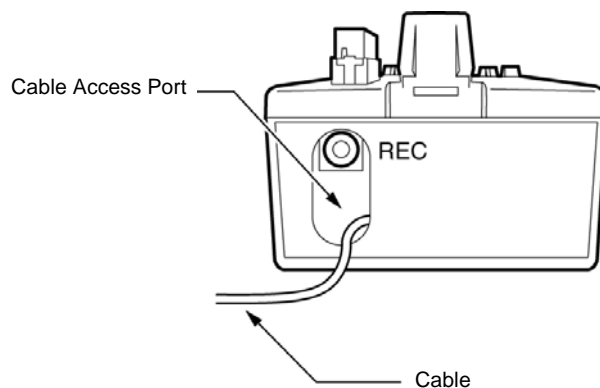

Figure 5-12: AD(A)-R() Unit Cable Access Port

3.2.2 Switch Settings

The AD(A)-R() Unit has two switch locations; SW1/SW2 and the DSW switches. The location of the switches on the AD(A)-R() Unit is illustrated in *Figure 5-13: AD(A)-R() Switch Default Settings*. The dip switches (DSW) allow a technician to configure the unit for specific settings.

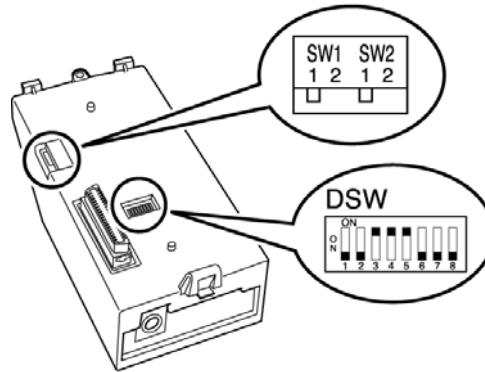

Figure 5-13: AD(A)-R() Switch Default Settings

To provide control to the recorder or to enable/disable the record start warning tones, refer to *Table 5-2: AD(A)-R() Unit Switch Settings*.

Table 5-2: AD(A)-R() Unit Switch Settings

Switch		Description/Settings
SW1	SW1-1	Connects to Multiline Terminal Connect = Default
	SW1-2	Not Used
SW2	SW2-1	Sets External Equipment Impedance to 600 Ω (< 30 Ω Input Impedance)
	SW2-2	Used for Complex Impedance Devices

Dip Switches (DSW)	DSW 1	Output Hook Signal to External Device On = Output Off = No Output (Default)
	DSW 2	Record Confirmation Tone On = Tone On Off = Tone Off (Default)
	DSW 3 and DSW 4	Use T1/T2 On = Disable (Default) Off = Enable
	DSW 5	Reset Signal Upgrade On = Normal (Default) Off = Debugging
	DSW 6~8	Firmware Upgrade On = Firmware Upgrade Off = Disable (Default)

Note: Do not connect T1 and T2 when DSW switches 3 and 4 are On.

3.2.3 Installing the AD(A)-R() Unit on a Multiline Terminal

The AD(A)-R() Unit should be installed **after** the cables have been connected and the switches set.

Note: If wall mounting the Multiline Terminal, a WM-R() Unit must be used. Refer to *Section 9: Wall Mounting Multiline Terminals* on page 1-178.

1. Unplug the telephone cord (and the ACA-U() Unit cord if installed) from the Multiline Terminal.
2. Plug the tabs marked **A** and **B** into adapter slots, then snap the tab on the other end of the adapter into the receptacle marked **C**. (Refer to *Section 9: Attaching the AD(A)-R() Unit to the Multiline Terminal on page 1-119.*)

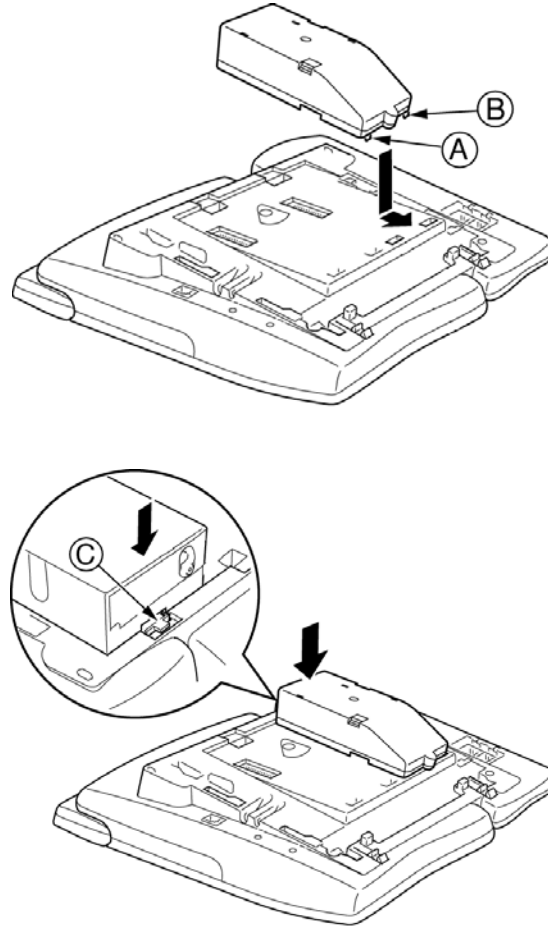

Figure 5-14: Attaching the AD(A)-R() Unit to the Multiline Terminal

3. Replace the base plate (or wall mount unit) and reattach the line cord. Refer to *Section 9: Connecting a Dterm Series i Multiline Terminal on page 1-169.*

3.3 AP(A)-R() Unit and AP(R)-R() Unit (Port Adapters)

The Analogue Port Adapter without Ringer [AP(A)-R() Unit] and the Analogue Port Adapter with Ringer [AP(R)-R() Unit] are used to install a Single Line Telephone, Modem, Credit Card Reader, Wireless Headset, Conferencing unit, or other compatible analogue devices.

The AP(R)-R() Unit generates ringing signals and requires an ACA-U() Unit.

The AP(A)-R() Unit and the AP(R)-R() Unit can be installed on all *D^{term}* Series i Multiline Terminals except the DTR-2DT-1A() TEL.

Figure 5-15: Connecting a Multiline Terminal to an Analogue Telephone Using an AP(A)-R() Unit/AP(R)-R() Unit (Example) illustrates how a terminal with an AP(A)-R() Unit/AP(R)-R() Unit is connected to the ESI(8)-U() and to an analogue telephone.

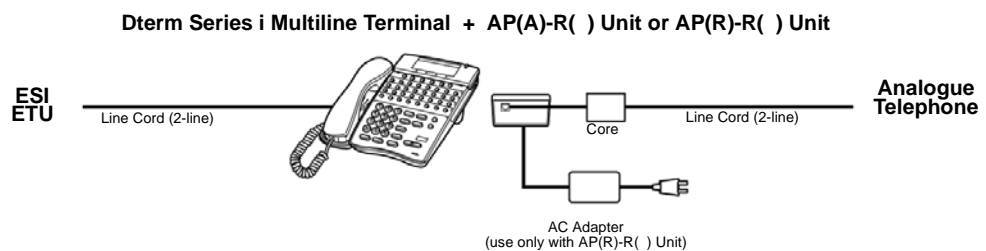

Figure 5-15: Connecting a Multiline Terminal to an Analogue Telephone Using an AP(A)-R() Unit/AP(R)-R() Unit (Example)

3.3.1 Switch Settings

The AP(A)-R() Unit and AP(R)-R() Unit have three switch locations. Refer to *Table 5-3: AP(A)-R()/AP(R)-R() Unit Switch Settings* for a description of each switch and an explanation of the settings.

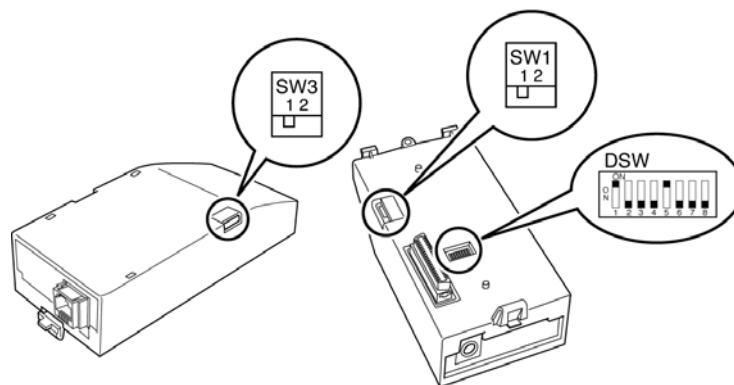

Figure 5-16: AP(A)-R() Unit/AP(R)-R() Unit Switches

Table 5-3: AP(A)-R()/AP(R)-R() Unit Switch Settings

Switch		Description/Settings
SW1	SW1-1	Connects to Multiline Terminal (Default)
	SW1-2	Not Used
SW3	SW3-1	Sets impedance to 600 Ω for devices such as modems or facsimile machines.
	SW3-2	Used for complex impedance devices such as Single Line Telephones.
Dip Switches (DSW)	DSW 1~8	Leave switches at default

3.3.2 Installing AP(A)-R() or AP(R)-R() Unit on a Multiline Terminal

The AP(A)-R() and AP(R)-R() Units should be installed **after** the switch settings have been set.

Note: If wall mounting the Multiline Terminal, a WM-R() Unit must be used. Refer to *Section 9: Wall Mounting Multiline Terminals on page 1-178*.

1. Prepare Multiline Terminal for adapter installation. Refer to *Section 9: Preparing for Adapter Installation on page 1-109*.
2. Plug the tabs marked **A** and **B** into adapter slots, then snap the tab on the other end of the adapter into the receptacle marked **C**. (Refer to *Section 9: Attaching the AP(A)-R()/AP(R)-R() Units to the Multiline Terminal on page 1-122*.)

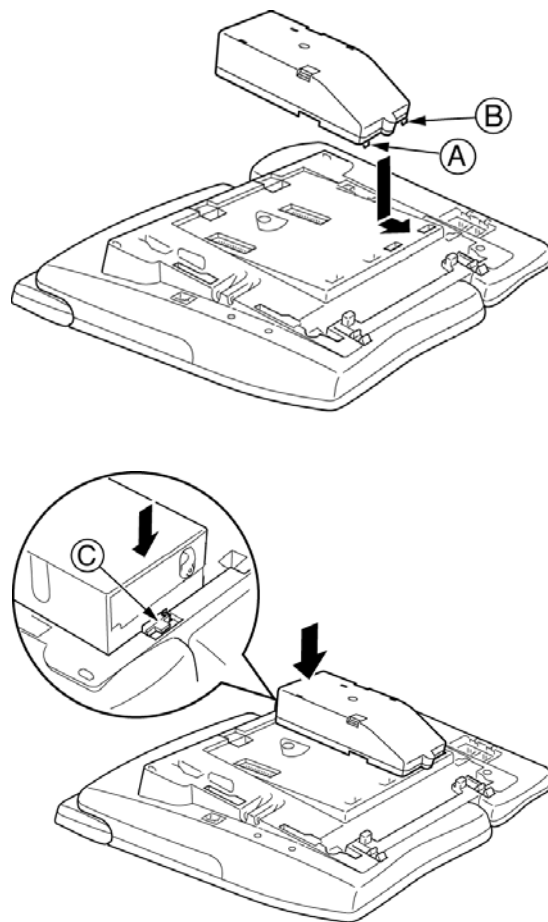

Figure 5-17: Attaching the AP(A)-R()/AP(R)-R() Units to the Multiline Terminal

3. Install the ferrite core (provided with the unit) about two 50mm from the line cord plug.

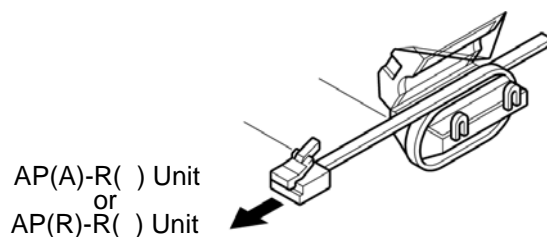

Figure 5-18: Installing the Ferrite Core on the AP(A)-R()/AP(R)-R() Units

4. Connect the line cord to the unit, limiting the cable length from the AP(A)-R()/AP(R)-R() Unit to the Single Line Telephone to a maximum of 15 meters.

Note: If only installing the AP(R)-R() Unit, plug the AC Adapter (ACA-U() Unit) power cord into the indicated AP(R)-R() Unit receptacle and connect it to a power source. (Refer to *Section 9: Connecting the AC Adapter to an Installed Adapter* on page 1-112.)

5. Replace the base plate (or wall mount unit) and reattach the line cord. (Refer to *Section 9: Connecting a Dterm Series i Multiline Terminal* on page 1-169.)

3.4 CT(U)-R() Unit (Computer Telephony Adapter)

The Computer Telephony Adapter [(CT(U)-R() Unit)] allows a Multiline Terminal to be connected to a PC using the PC USB port.

Connecting using the USB port provides telephony and sound device control. The general functions of the CT(U)-R() Unit include:

- ④ Telephony Control

The application is based on the Microsoft Telephony Application Programming Interface (TAPI) and provides call handling on the PC (e.g., call, answer, hold, transfer, conference, or caller ID).

- ④ User Interface to Support D^{term} Emulation

This function provides the functions of the D^{term} such as normal telephone indications, LCD, line keys or hookswitch.

- ④ Sound Support

Allows voice recording or recording playing on an audio device assigned to a PC. Voice Mail and Live Record are supported on the PC.

- ④ Plug and Play

An ACA-U() Unit is necessary when using this unit.

This adapter can be installed on any D^{term} Series i Multiline Terminal except the DTR-2DT-1A() TEL.

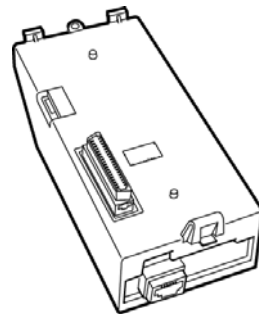

Figure 5-19: CT(U)-R() Unit

Figure 5-20: Connecting a Multiline Terminal to a PC using a CT(U)-R() Unit (Example) illustrates how a terminal with a CT(U)-R() Unit is connected to the ESI(8)-U() ETU and to the PC.

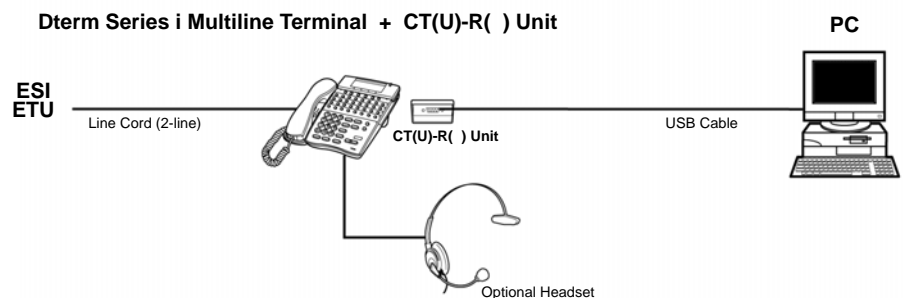

Figure 5-20: Connecting a Multiline Terminal to a PC using a CT(U)-R() Unit (Example)

3.4.1 Installing the CT(U)-R() Unit

The CT(U)-R() Unit should be installed **after** the switch settings have been set.

Note: If wall mounting the Multiline Terminal, a WM-R() Unit must be used. Refer to *Section 9: Wall Mounting Multiline Terminals* on page 1-178.

1. Prepare Multiline Terminal for adapter installation. Refer to *Section 9: Preparing for Adapter Installation* on page 1-109.
2. Plug the tabs marked **A** and **B** into adapter slots, then snap the tab on the other end of the adapter into the receptacle marked **C**. Refer to *Figure 5-21: Attaching the CT(U)-R() Unit to the Multiline Terminal*.

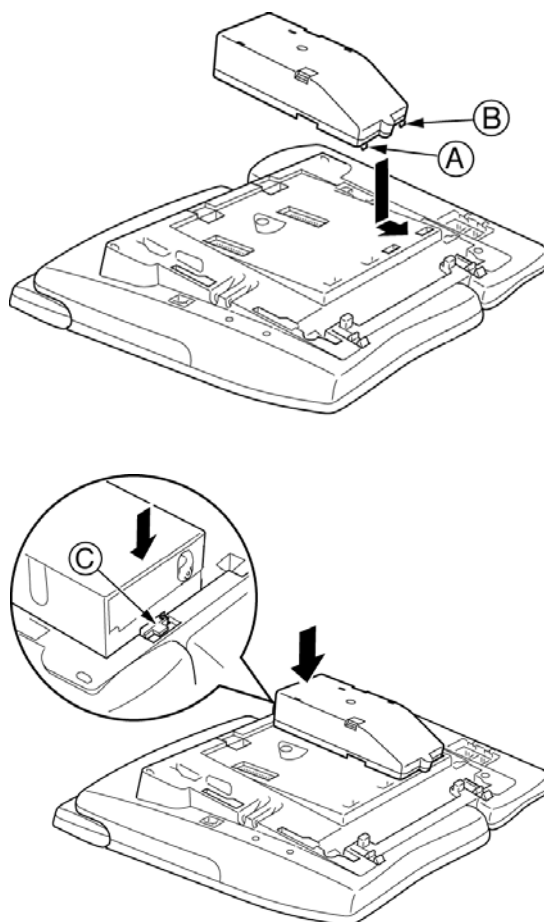

Figure 5-21: Attaching the CT(U)-R() Unit to the Multiline Terminal

3. Replace the base plate (or wall mount unit) and reattach the line cord. Refer to *Section 9: Connecting a Dterm Series i Multiline Terminal* on page 1-169.

3.4.2 Connecting the CT(U)-R() Unit to the PC

Connect USB cable from the PC to the CT(U)-R() Unit as illustrated in *Figure 5-22: Connecting the USB Cable to the CT(U)-R() Unit*.

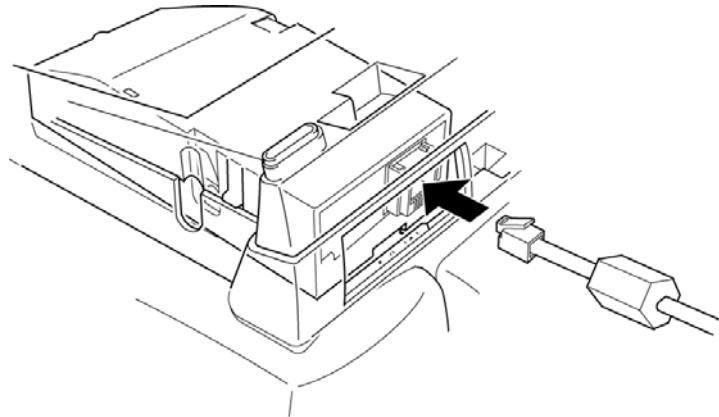

Figure 5-22: Connecting the USB Cable to the CT(U)-R() Unit

3.4.3 Installing the Optional Headset

Install the headset and anchor it in the cord slot on the Multiline Terminal as illustrated below.

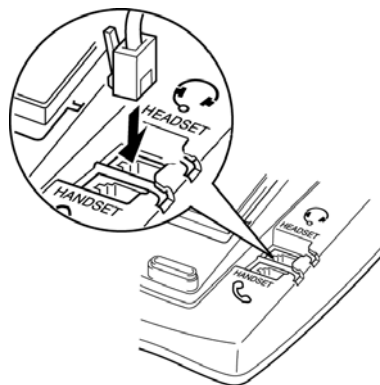

Figure 5-23: Attaching the Headset to the Multiline Terminal

3.4.4 Installing the Driver on the PC

Using the setup disk provided with the CT(U)-R() Unit install the driver onto your PC. Refer to the CT(U)-R() Unit installation instructions for installing the driver in the CT Adapter Installation Manual.

This page is intentionally blank.

Installing DTU-Type Multiline Terminals

SECTION 1 GENERAL INFORMATION

The Xen Alpha system provides four different DTU-Type Multiline Terminals, and several adapters that allow peripheral equipment to be attached to these Terminals. This chapter describes each terminal and adapter, it also provides applicable installation instructions.

SECTION 2 MULTILINE TERMINALS

DTU-8-1A (WH) TEL

This digital non-display Multiline Terminal is equipped with eight programmable line keys (each with a two-colour LED), a built-in speakerphone, headset jack, a large LED to indicate incoming calls and messages, and compatibility with ADA-UA, APR-UA, CTA-BA, and HFU-UA Units.

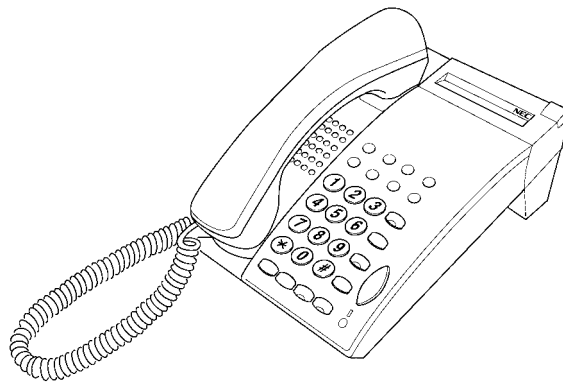

Figure 6-1: DTU-8-1A (WH) TEL Multiline Terminal

DTU-8D-1A (WH)/(BK) TEL

This digital Multiline Terminal has eight programmable line keys (each with the two-colour LED), four softkeys, a built-in speakerphone, headset jack, a Large LED to indicate incoming calls and messages, and compatibility with ADA-UA, APR-UA, CTA-BA, and HFU-UA Units.

This terminal is also equipped with a 3-line, 24-character, adjustable Liquid Crystal Display (LCD).

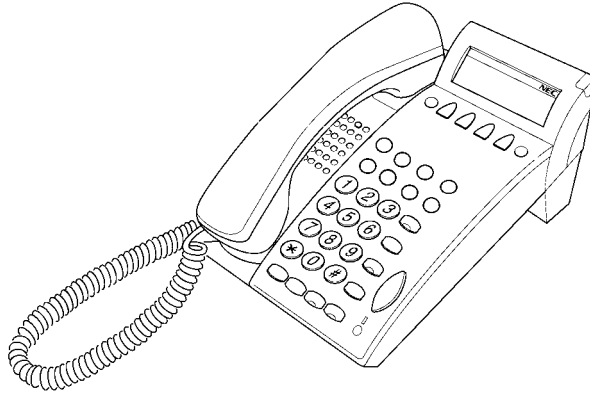

Figure 6-2: DTU-8D-1A (BK)/(WH) TEL Multiline Terminal

DTU-16D-1A (WH)/(BK) TEL

This digital Multiline Terminal has 16 programmable line keys (each with a two-colour LED), four softkeys, a built-in speakerphone, headset jack, a large LED to indicate incoming calls and messages, and compatibility with ADA-UA, APR-UA, CTA-BA, and HFU-UA Units.

This terminal is also equipped with a 3-line, 24-character, adjustable Liquid Crystal Display (LCD).

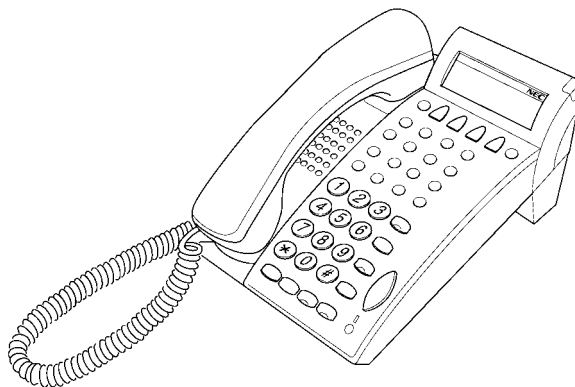

Figure 6-3: DTU-16D-1A (WH)/(BK) TEL Multiline Terminal

DTU-32D-1A (WH)/(BK) TEL

This digital Multiline Terminal has 16 programmable line keys (each with a two-colour LED), 16 one-touch keys, four softkeys, a built-in speakerphone, headset jack, a large LED to indicate incoming calls and messages, and compatibility with ADA-UA, APR-UA, CTA-BA, and HFU-UA Units.

This terminal is also equipped with a 3-line, 24-character, adjustable Liquid Crystal Display (LCD).



Figure 6-4: DTU-32D-1A (WH)/(BK) TEL Multiline Terminal

SECTION 3 CONNECTING A MULTILINE TERMINAL TO THE SYSTEM

These instructions for connecting a Multiline Terminal to the system applies to all of the DTU-type Multiline Terminals.

1. Plug the telephone cord into the modular jack on the bottom side of the Multiline Terminal. The handset is also attached to the bottom side of the Multiline Terminal.

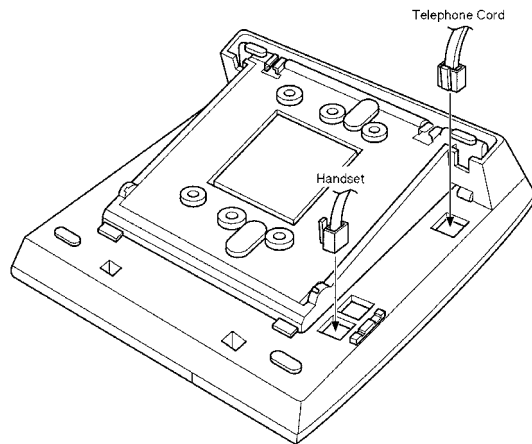

Figure 6-5: Connecting a Multiline Terminal to the System

2. Lead the telephone and handset cords through the appropriate grooves.

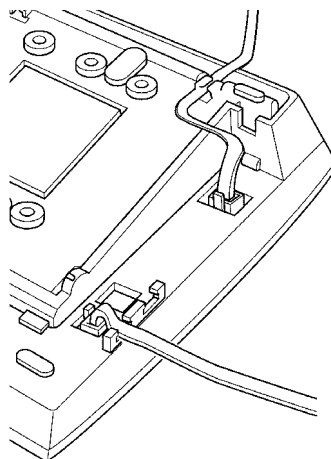

Figure 6-6: Leading Line Cords on a Multiline Terminal

SECTION 4 **ADJUSTING THE** **LCD**

The adjustable Liquid Crystal Display (LCD) comes equipped on the display DTU-type Multiline Terminals. The LCD can be adjusted by pushing downward and upward as desired.

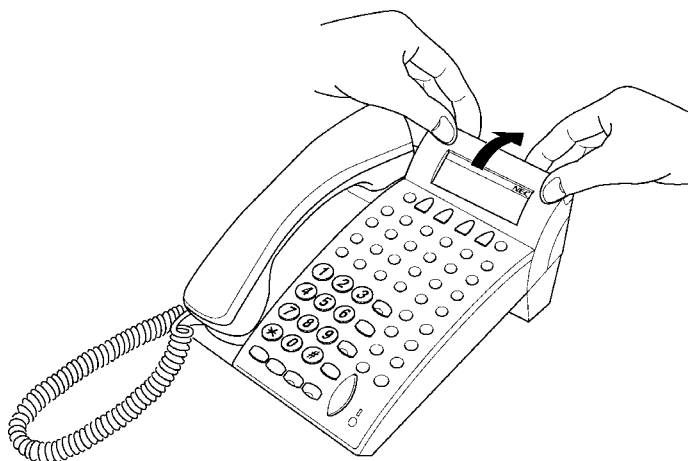

Figure 6-7: Adjusting the LCD

SECTION 5 INSTALLING LINE CARDS & PLASTIC PANELS

Line Card and Plastic Panel Installation

Line Cards can be used to print the line key designations. These are then placed on the Multiline Terminal providing a quick reference of key designations to the Multiline Terminal users. The Line Cards can be changed as necessary. The Plastic Panel is placed on top of the Line Card to hold it in place.

1. Place the Line Card over the keys on the Multiline Terminal.
2. Place the tabs on the bottom of the plastic panel into the grooves at the terminal bottom, and press top right and left ends to secure plastic panel to the Multiline Terminal. Refer *Figure 6-8: Installing Line Card and Plastic Panel on a Multiline Terminal*.

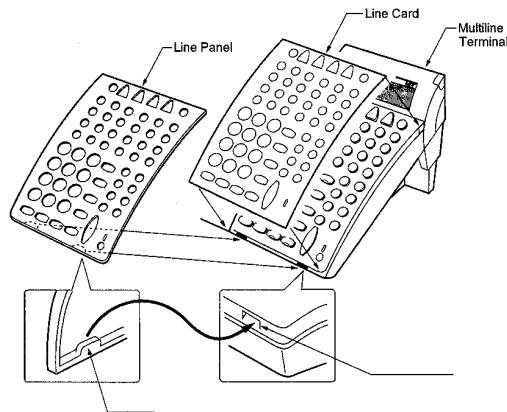

Figure 6-8: Installing Line Card and Plastic Panel on a Multiline Terminal

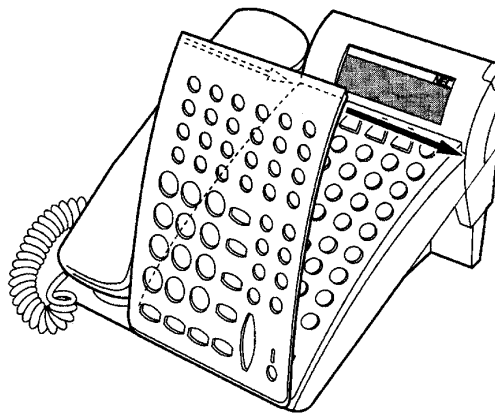

Figure 6-9: Installing Plastic Panel

Plastic Panel Removal

Lift the right corner, raise the panel and slide the bottom away from the Multiline Terminal.

NEVER pull on the bottom of the plastic panel to remove it. Damage to the plastic panel could result

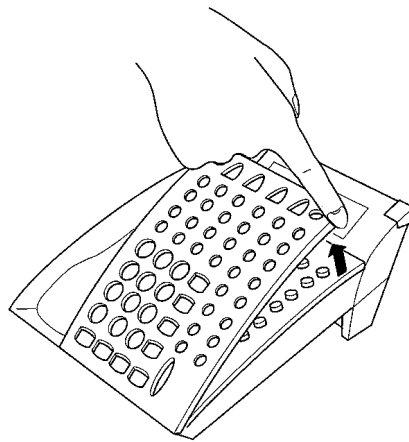

Figure 6-10: Removing the Plastic Panel from the Multiline Terminal

SECTION 6 REMOVING SOFTKEYS

If softkeys are not going to be used on the Multiline Terminal they can be removed. This section describes the process for removing the keys.

1. Remove the softkeys by pulling the softkey plate upward as shown in *Figure 6-11: Removing Softkeys*.

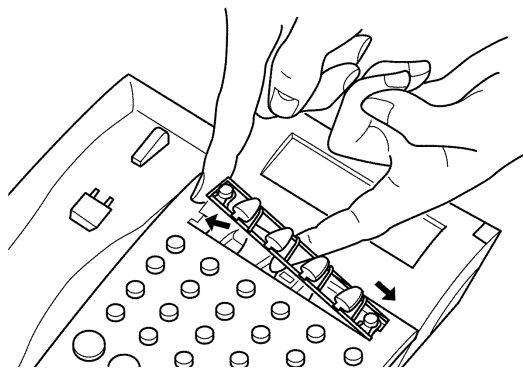

Figure 6-11: Removing Softkeys

2. Install the plastic panel again.

SECTION 7 ADJUSTING THE HEIGHT OF THE MULTILINE TERMINAL

The base plate on DTU-type Multiline Terminals are hinged. The bottom portion can be adjusted up or down to raise or lower the height of the terminal.

1. Turn the Multiline Terminal upside down and locate the tabs as shown in *Figure 6-12: Locating the Adjustment Tabs on the Multiline Terminal*.

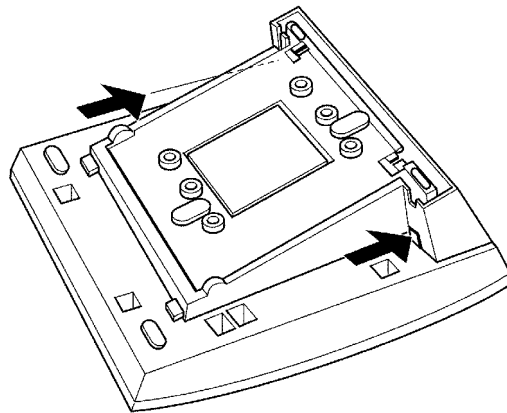

Figure 6-12: Locating the Adjustment Tabs on the Multiline Terminal

2. Push the adjustment tabs and raise the base plate until it locks.

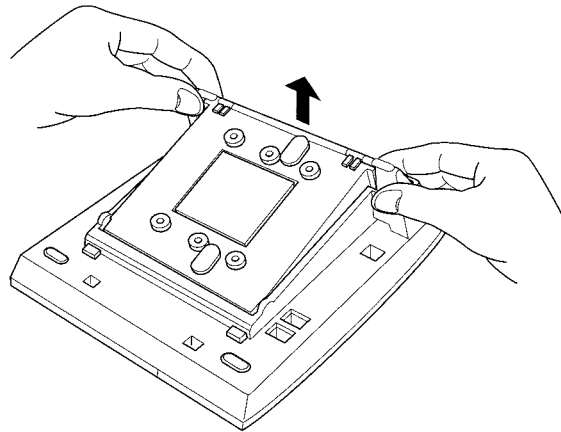

Figure 6-13: Raising the Base Plate on the Multiline Terminal

3. The length of the cord can be adjusted by pulling the line cord through the groove in the bottom of the Multiline Terminal.

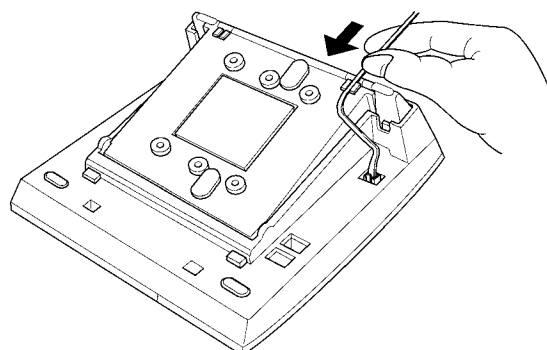

Figure 6-14: Adjusting the Line Cord Length

- To lower the base plate on the Multiline Terminal, push on the adjustment tabs and push the base plate downward.

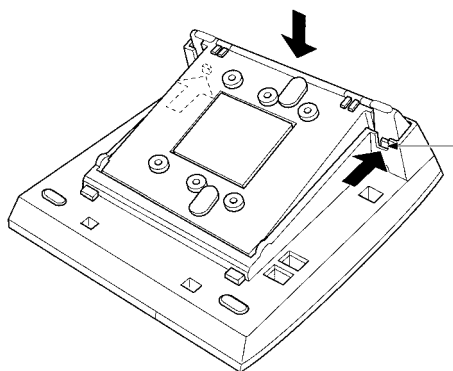

Figure 6-15: Lowering the Base Plate on the Multiline Terminal

SECTION 8 WALL MOUNTING

Any DTU-Type Multiline Terminal can be mounted on a wall. Multiline Terminals can be wall mounted by using the base unit that comes with the Multiline Terminal or by using the WMU-UA Unit to accommodate adapters that are installed on the Multiline Terminal.

Removing and Remounting the Handset Hanger

- Remove the hanger by sliding it out of the slot.
- Install it back in its original position so that the hanger protrudes providing a rest for the handset. (This procedure applies when using either the base unit or the WMU-UA Unit.) Refer to *Figure 6-16: Positioning the Handset Hanger* for the steps for removing and remounting the handset hanger.

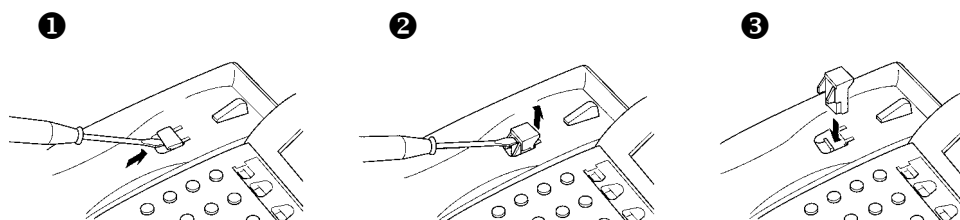

Figure 6-16: Positioning the Handset Hanger

Wall Mounting, Using the Base Unit

- Refer to *Section 9: Preparing Multiline Terminal for Adapter Installation*, and perform Steps 1 – 5.
- Press both sides of the base cover and turn it left to remove it.
- Rotate base cover 180° and install it again on the Multiline Terminal.

4. Remove the shaded base plate knockout shown on *Figure 6-17: Removing the Knockout*

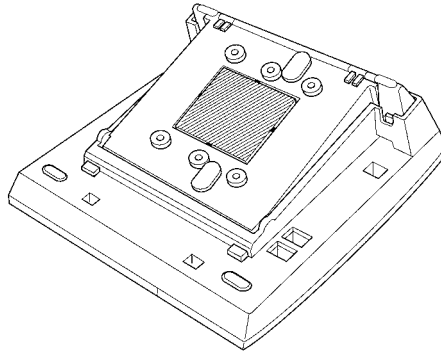

Figure 6-17: Removing the Knockout

5. Assemble the base plate and base cover.
6. As illustrated in *Figure 6-18: Attaching the Base Plate to the Wall*, attach the base plate and base cover assembly (wide end down) to the posts on the locally provided and installed wall plate. Place locally provided screws in the nodes on the base plate and secure the assembly to the wall.

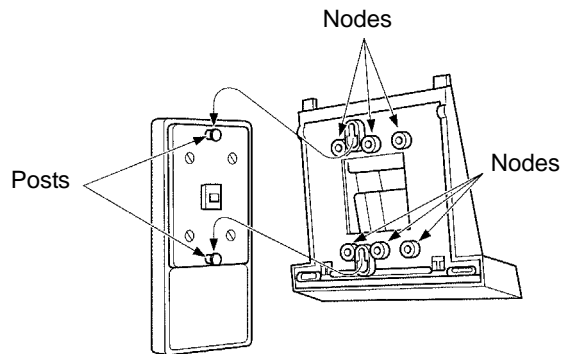

Figure 6-18: Attaching the Base Plate to the Wall

If using a modular jack instead of a wall plate, put the modular jack inside the base unit as shown in *Figure 6-19: Wall Mounting using a Modular Jack*. Use the locally provided screws to attach the base unit directly to the wall.

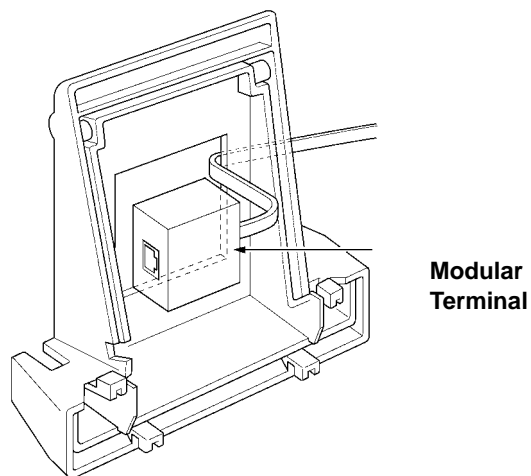

Figure 6-19: Wall Mounting using a Modular Jack

7. Plug the line cord into the jack on the wall plate, wrap the extra cord and secure it with a tie wrap, and lead the line cord out through the groove in the side of the base unit.

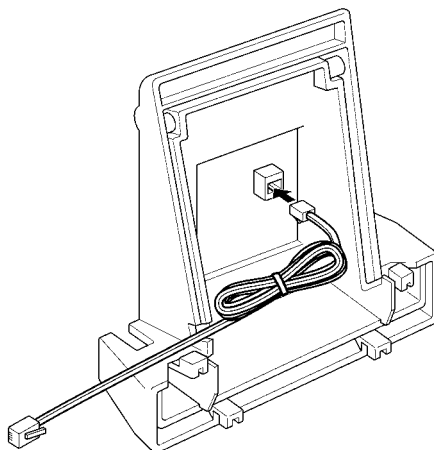

Figure 6-20: Plugging in the Line Cord using a Wall Jack

If using a modular jack instead of a wall plate, plug the line cord into the modular jack, wrap the extra cord and secure it with a tie wrap, and lead the line cord out through the groove in the side of the base unit.

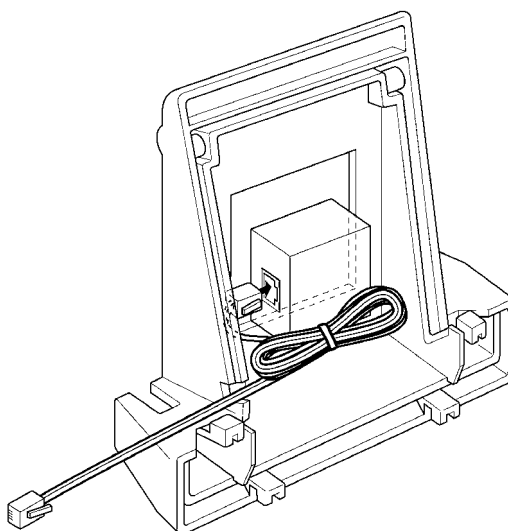

Figure 6-21: Plugging in the Line Cord Using a Modular Jack

8. With the base plate and base cover assembly attached to the wall, hook the two bottom tabs on the base cover into the tab slots on the base of the Multiline Terminal.

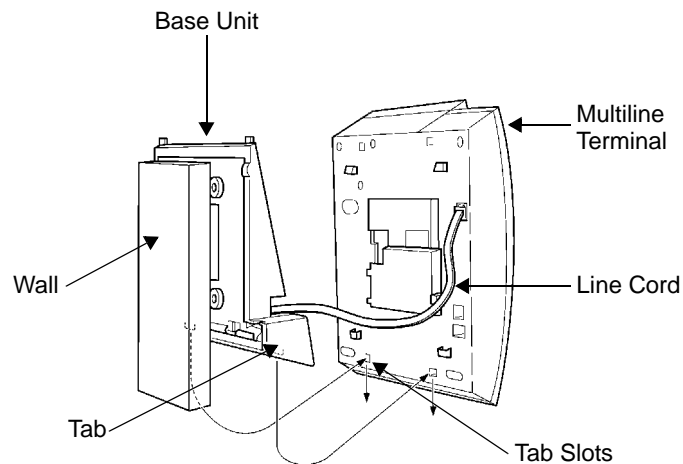

Figure 6-22: Attaching the Bottom Tabs of the Multiline Terminal to the Base Cover

9. Push up on the Multiline Terminal and lock the top tabs on the base cover into the tab slots on the base of the Multiline Terminal. Turn terminal slightly clockwise to interface with base cover. *Figure 6-23: Attaching the Top Tabs of the Multiline Terminal to the Base Plate* shows how the Multiline Terminal is attached.

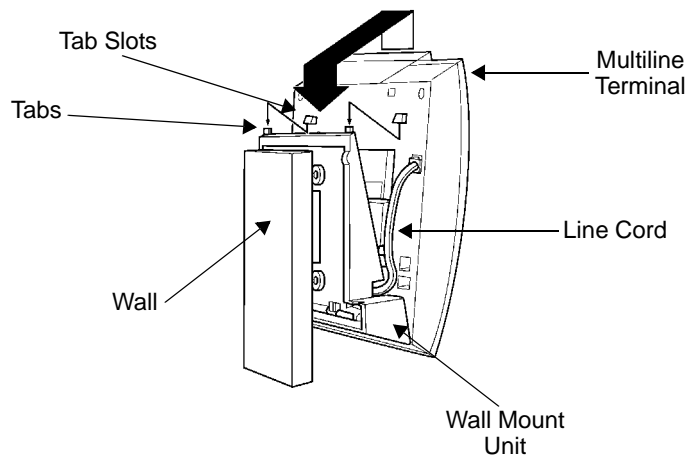

Figure 6-23: Attaching the Top Tabs of the Multiline Terminal to the Base Plate

10. When properly installed, the wall-mounted Multiline Terminal looks similar to the one shown in *Figure 6-24: Installed Wall Mount Unit*.

NOTE: Do not adjust the tilt panel LCD after the Multiline Terminal is mounted on the wall.

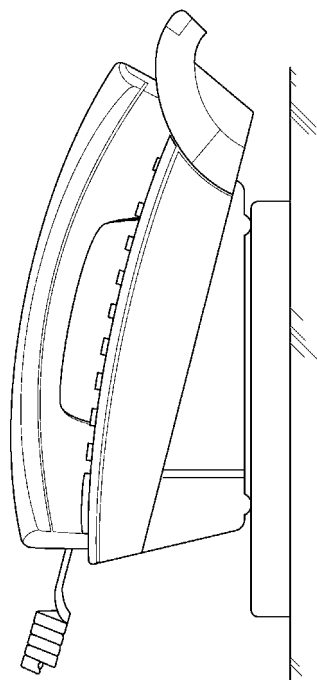

Figure 6-24: Installed Wall Mount Unit

Installing the Wall Mount Unit & Mounting the Multiline Terminal Using the WMU-UA Unit

If installing an HFU-UA Unit, CTA-BA Unit, or APR-UA Unit, a separate WMU-UA Unit must be purchased to accommodate these units.

1. Remove the line cord, base plate and base cover from the Multiline Terminal as shown in the previous section.
2. Cut off the tabs on the adapter as shown in *Figure 6-25: Removing the Tabs from the Adapter*.

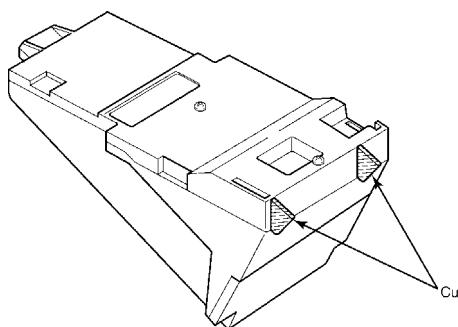

Figure 6-25: Removing the Tabs from the Adapter

3. Remove the tabs from the WMU-UA Unit as shown in *Figure 6-26: Removing the Tabs from the WMU-UA Unit*. (Tabs removed depends on the Multiline Terminal type.)

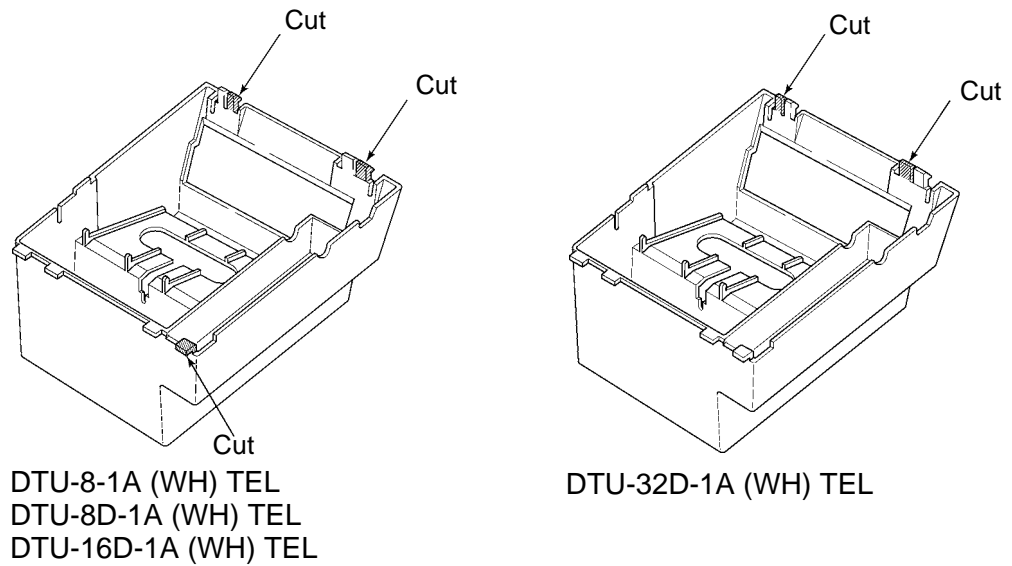

Figure 6-26: Removing the Tabs from the WMU-UA Unit

4. Bundle the cord from the modular jack leaving about eight inches. Use a tie wrap to secure the bundled cord.
5. Place the bundled line cord in the space between the WMU-UA Unit and the wall. Lead the line cord out through the slits as shown in *Figure 6-27: Leading the Line Cord out of the WMU-UA Unit*.

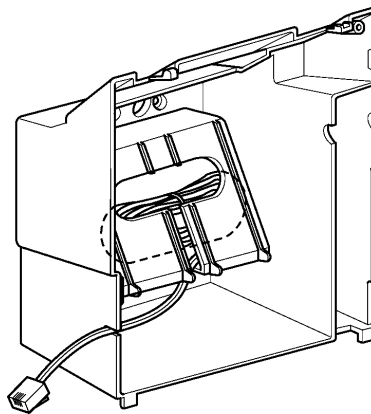

Figure 6-27: Leading the Line Cord out of the WMU-UA Unit

6. Attach the WMU-UA Unit to the posts on the wall plate (locally provided). Place locally provided screws in the nodes on the WMU-UA Unit and secure the WMU-UA Unit to the wall.

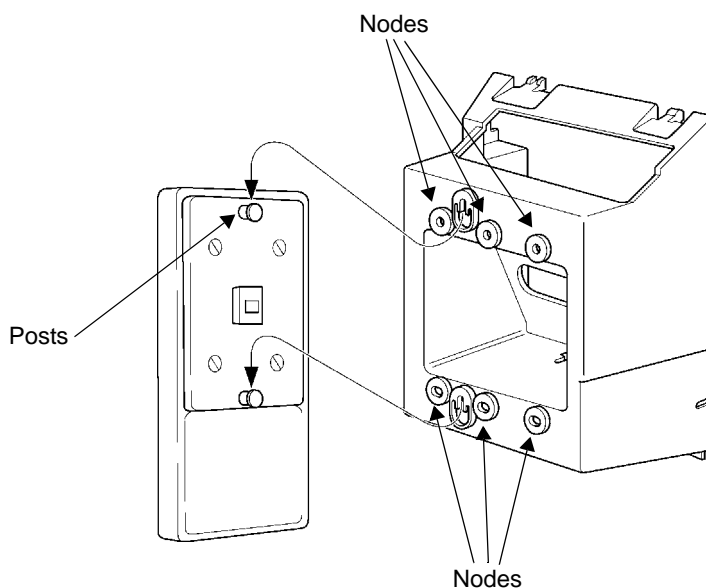

Figure 6-28: Attaching the Wall Mount Unit to the Wall

7. Connect the line cord to the Multiline Terminal.
8. With the WMU-UA Unit attached to the wall, hook the two bottom tabs on the WMU-UA Mount Unit into the tab slots on the Multiline Terminal. Then push the two top tabs on the WMU-UA Unit into the tab slots on the Multiline Terminal. If the adapter has a power supply, lead the AC adapter cord out through the opening at the bottom of the Multiline Terminal. Refer to *Figure 6-29: Attaching the Multiline Terminal to the WMU-UA Unit*.

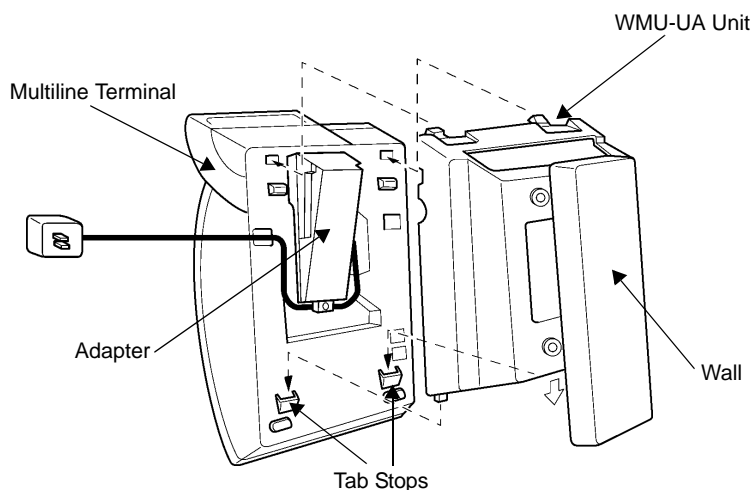

Figure 6-29: Attaching the Multiline Terminal to the WMU-UA Unit

Removing the Multiline Terminal from the Base Cover

To remove the Multiline Terminal from the base cover, lift the Multiline Terminal to disengage top tabs, turn it slightly counter clockwise to unlock lower tabs on base cover, and remove it.

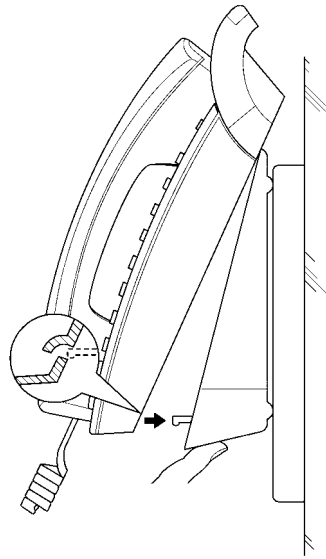

Figure 6-30: Removing the Multiline Terminal from the Base Cover

Removing the Multiline Terminal from the WMU-UA Unit

To remove the Multiline Terminal from the WMU-UA Unit, lift the Multiline Terminal to disengage top tabs and lower the terminal from the WMU-UA Unit.

SECTION 9 INSTALLING OPTIONAL ADAPTERS

Optional equipment is available to enhance the Xen system. This equipment can be purchased separately from the system and added as the customer business needs grow. All these adapters can be installed on the DTU-Type Xen Multiline Terminals.

A Multiline Terminal can have up to three adapters installed at the same time. If attaching an APR-UA Unit, a CTA-BA Unit, or an HFU-UA Unit, an external power supply is required. Only **one** power supply is needed even if more than one adapter is installed.

When an adapter is installed for the first time into a telephone, the base cover on the Multiline Terminal may have to be modified. The base cover has two access panels that are removed before the cover can be closed over the adapters to complete the installation.

Preparing Multiline Terminal for Adapter Installation

To prepare the Multiline Terminal for adapter installation:

1. Unplug the telephone cord from the terminal.
2. Turn the terminal upside down. Push the tabs indicated in *Figure 6-31: Raising the Base Plate*, and raise the inner area of the base plate.

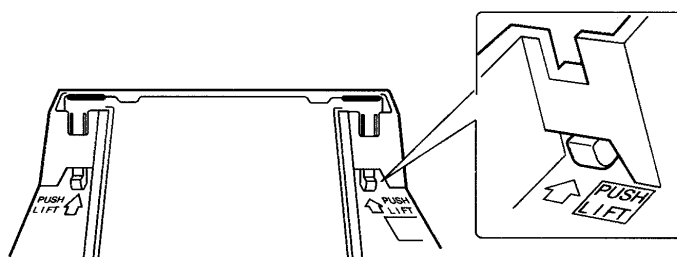

Figure 6-31: Raising the Base Plate

3. Insert flat head screwdriver into A in *Figure 6-32: Unlocking Tab* and press straight down until tab unlocks.

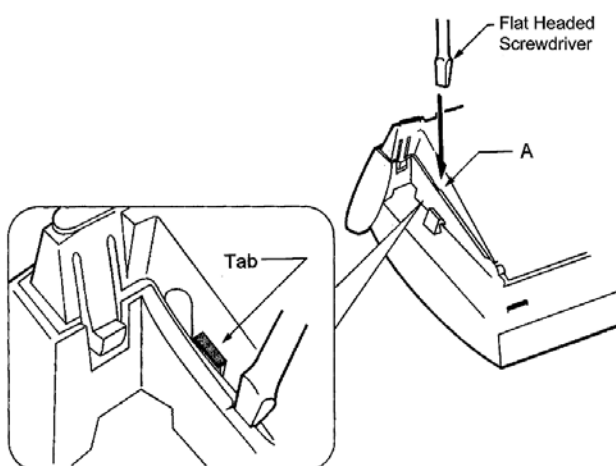

Figure 6-32: Unlocking Tab

- Lightly press right side of leg shown as B in *Figure 6-33: Releasing Right Tab*, insert flat head screwdriver at C and Press straight down until other tab unlocks.

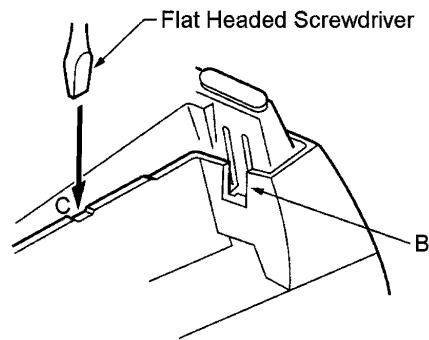

Figure 6-33: Releasing Right Tab

- Open and remove Bottom Cover by rotating counterclockwise as shown in *Figure 6-34: Removing Bottom Cover*.

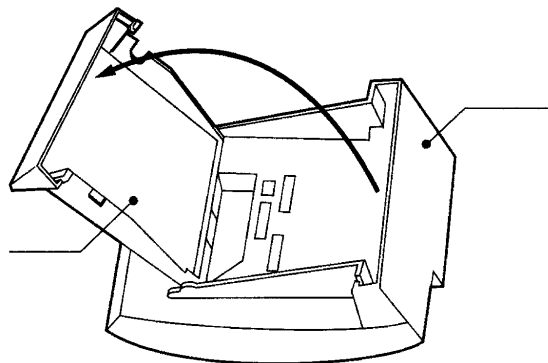

Figure 6-34: Removing Bottom Cover

- If an adapter is being installed, press tabs A and B to remove the dummy end from the base plate as shown in *Figure 6-35: Removing Base Plate Dummy End*.

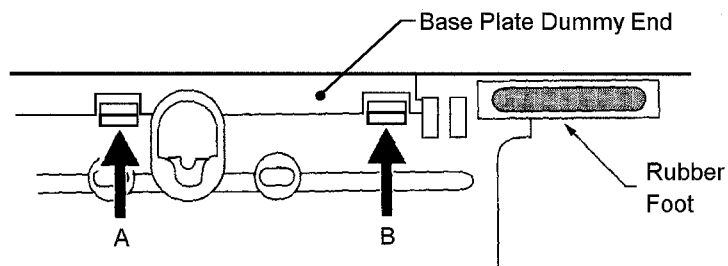

Figure 6-35: Removing Base Plate Dummy End

- Cut the dummy end in half as shown in *Figure 6-36: Cutting Dummy End in Half*.

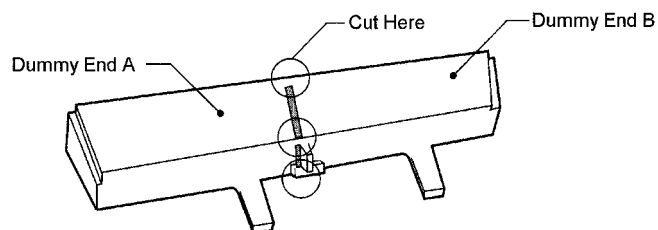

Figure 6-36: Cutting Dummy End in Half

8. If Adapter is installed in Connector 1 as show in *Figure 6-37: Installing Adapter in Connector 1*, Install Dummy end B as shown in *Figure 6-38: Installing Dummy End B*.

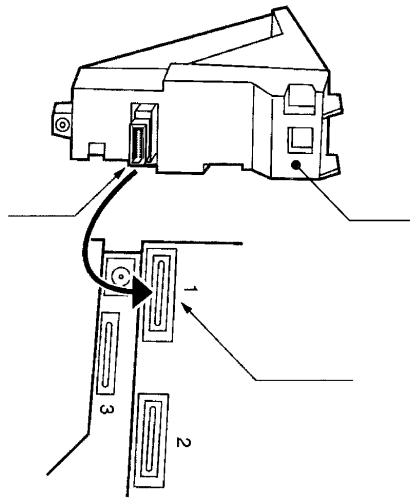

Figure 6-37: Installing Adapter in Connector 1

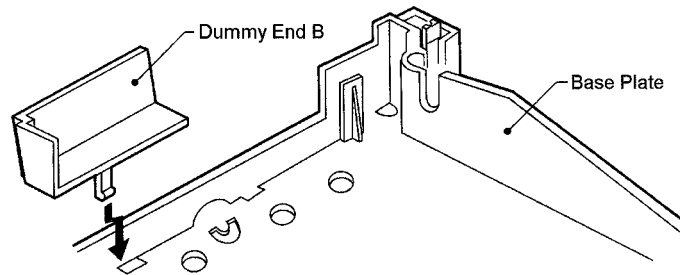

Figure 6-38: Installing Dummy End B

ACA-UA Unit (AC Adapter)

This unit provides power to ancillary devices. The ACA-UA Unit must be connected to an adapter that is installed on a Multiline Terminal. If more than one adapter is installed on a Multiline Terminal, only one ACA-UA Unit is necessary.

The power requirements for the ACA-UA Unit are:

- Input: 240 Vac, 50 Hz
- Output: 24V DC, 400 mA
- Polarity: \ominus ————— \oplus

1. Connecting the ACA-UA Unit
 - a) Unplug the line cord from the Multiline Terminal and unplug the ACA-UA Unit from the AC outlet. (Failing to do this can damage the unit and/or the Multiline Terminal.)
 - b) Turn the Multiline Terminal upside down and open the base plate.
2. Locate the AC adapter plug on the ancillary device that is connected to the bottom of the Multiline Terminal and plug in the AC adapter.

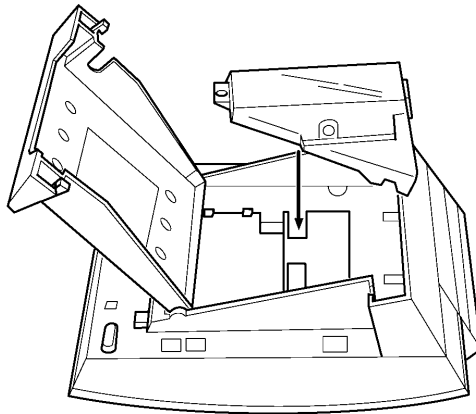

Figure 6-39: ACA-UA Unit Connection

ADA-UA Unit (Ancillary Device Adapter)

Ancillary Device Adapters allow connection of a recording device to DTU-type Multiline Terminals.

When installing an ADA-UA Unit, first connect the cables to the ADA-UA Unit, set the dip switches, and then install the ADA-UA Unit on the Multiline Terminal.

1. Installing an ADA-UA Unit on a Multiline Terminal
 - a) Unplug the telephone cord from the Multiline Terminal.
 - b) Prepare Multiline Terminal for adapter installation. Refer to Section 2 Preparing Multiline Terminal for Adapter Installation.
 - c) Plug the ADA-UA Unit connector into the receptacle connector on the back of the Multiline Terminal. Snap the ADA-UA Unit into the hooks on the Multiline Terminal to secure it.

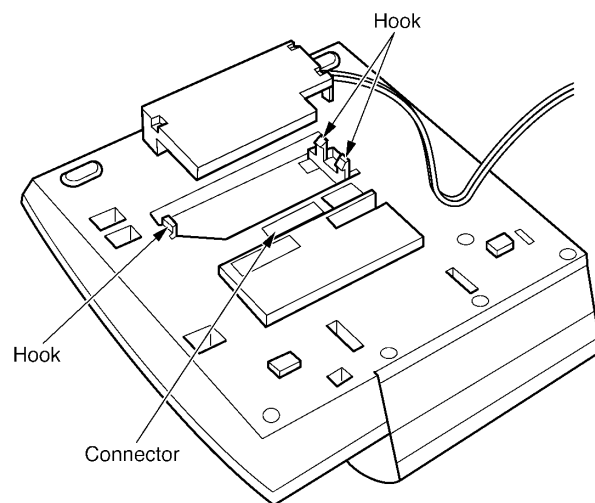

Figure 6-40: Attaching the ADA-UA Unit to the Multiline Terminal

- d) Replace base plate.
- e) Lead the audio cable out through the groove on the base cover. Plug in the telephone cord.

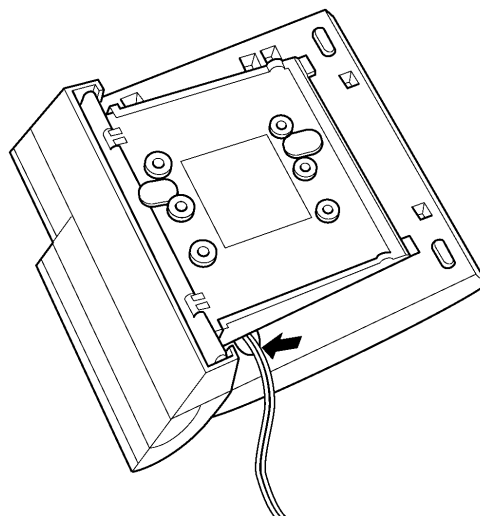

Figure 6-41: Leading the Audio Cable out from the ADA-UA Unit

Connecting Cables to the ADA-UA Unit

Cable terminal connectors are located on the right side of the ADA-UA Unit. Cables should be connected on this unit before installing the unit on the Multiline Terminal.

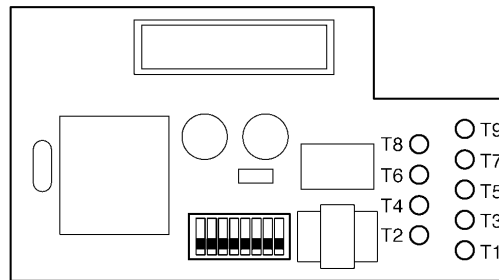

Figure 6-42: ADA-UA Unit

1. Cut off the plug on one end of the cable.
2. Locate the adapter terminals on the right side of the unit as illustrated in *Figure 6-42: ADA-UA Unit*.
3. Remove the cap on the adapter terminal to expose the metal receptacle. Push the cable in the applicable receptacle, and replace the cap. Line up the slot on the cap with the slot on the metal receptacle to ensure proper contact. Refer to *Figure 6-43: Attaching Cables to the ADA-UA Unit*.

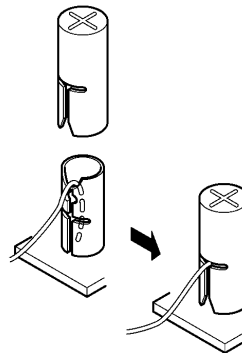

Figure 6-43: Attaching Cables to the ADA-UA Unit

4. Insulate the end of the cable that needs to be shielded with insulating tape. *Table 6-2: ADA-UA Unit Switch Settings* provides a list of cable connections to ADA-UA ADP terminals and describes the specifications for the terminals.
Table 6-1: ADA-UA Cable Connections provides a list of cable connections to ADA-UA ADP terminals and describes the specifications for the terminals.

Table 6-1: ADA-UA Cable Connections

Terminal Number	Cables to Connect	Terminal Specifications
T1	When warning tone is not being sent from the recorder, connect wire pair input from tone generator to T1:T2.	Input Terminal:T1 and T2 are enabled for tone generating device when DIP switches 3 and 4 are OFF.
T2	The warning tones from the generator are sent to T1:T2 on a dedicated wire pair while the speech path is sent from the ADA-UA on T3:T4 over a separate wire pair to the recorder.	(If switches 3 and 4 are ON, a humming sound may be recorded due to impedance mismatch.) Input Impedance on T1 and T2: 100K Ω Input Level on T1 and T2: -15 dB ~ 40 dB
T3	Connect recorder device wire pair speech input to T3:T4.	Input/Output Terminal: Refer to dip switch settings in <i>Table 6-2: ADA-UA Unit Switch Settings</i> .
T4	If the recorder used supplies a warning tone, this tone may also be sent over the T3:T4 wire pair back to the terminal.	
T5	Connect the bare end of the control cable.	When a Multiline Terminal is idle, this contact is closed. When the Multiline Terminal goes off-hook (using the handset, headset, or speakerphone), this contact is open. <i>If recorder owner manual specifies start on open circuit, connect T5 and T6.</i>
T6	Connect the shielded end of the control cable.	Provides common connection for control cable.
T7	Connect the bare end of the control cable.	When the Multiline Terminal is idle, this contact is open. When the Multiline Terminal is busy (using the handset, headset, or speakerphone), this contact is closed. <i>If recorder owner manual specifies start on closed circuit, connect T6 and T7.</i>
T8	Unused	
T9	Unused	

Notes:

- * When recording in handsfree (half-duplex) mode using the built-in speakerphone, the record warning tone may not be audible to the far-end party.
- * The transmit recording level is lower than the receiving voice level for intercom calls; the transmit recording level for CO calls is normal.
- * Depending on the recording device(s), separate cables may be required for the warning tone and speech path. In this case, connect the warning tone cables to input terminals T1 and T2 on the ADA-UA Unit. (T3 and T4 are used as the Analogue recorder input.)
- * If remote control of the recorder is necessary, the record start/stop control is provided by connecting to T5 (or T7) and T6 on the ADA-UA Unit. (Connecting to T5 or T7 is determined by the specifications of the recorder.)
- * If a warning Tone is provided from the recording equipment, it should be input via T3 and T4 on ADA-UA Unit. (Do not use T1 and T2 to input Beep Tone.)
- * Conversations cannot be recorded from terminals connected to an APR-UA Unit. Speakerphone calls through the HFU-UA Unit cannot be recorded.

Switch Settings

The DIP Switch is located at the bottom center of the ADA-UA Unit. The DIP Switch allows a technician to configure the board to specific settings. *Figure 6-44: ADA-UA Unit Switch Settings* shows the default settings.

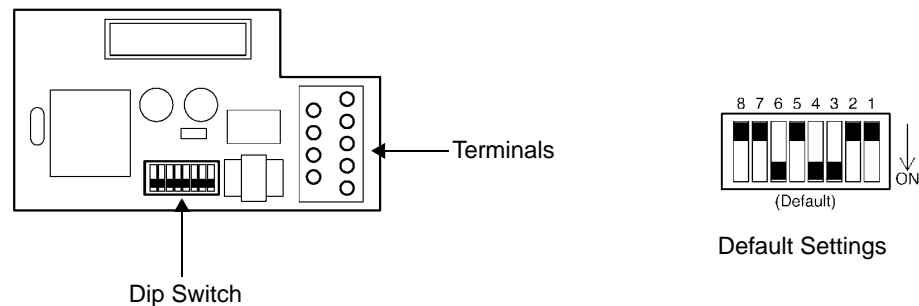

Figure 6-44: ADA-UA Unit Switch Settings

The following switch settings should be made on the ADA-UA Unit to enable or disable the record start warning tone. Switch settings should be made before installing the ADA-UA Unit in the Multiline Terminal. (Refer to *Table 6-2: ADA-UA Unit Switch Settings*.)

Table 6-2: ADA-UA Unit Switch Settings

Switch	Setting		Description
SW1-1	On		If the ADA-UA provides control to the recorder, SW1-1 should be set to On, otherwise set it to Off.
SW1-2	Off		Leave Off
SW1-3 and SW1-4	SW1-3 ON	SW1-4 ON	Warning Tone from recording device over same wire pair as speech path.
	SW1-3 OFF	SW1-4 OFF	Warning Tone from recorder or generator equipment on dedicated wire pair to recorder MIC input
SW1-5 and SW1-6	SW1-5 OFF	SW1-6 ON	Input impedance is 600 ohm
	SW1-5 ON	SW1-6 OFF	Input impedance is less than 600 ohm
SW1-7	ON		If warning tone from any device is sent to telephone
SW1-8	Off		Leave Off

* Do not connect T1 and T2 when switches 3 and 4 are ON.

APR-UA Unit (Analogue Port Ringer)

The Analogue Port adapter with Ringing provides an interface for installing Single Line Telephones, modems, NEC VoicePoint Conferencing unit, and other compatible analogue devices. The APR-UA Unit also generates ringing signals. By providing ring generation, the user can install a personal fax machine or an answering machine for convenience. Two user-adjustable switches are provided on the adapter; one allows for 600 ohm or a complex impedance interface to devices such as a modem or Single Line Telephone, the second switch (SW1) is permanently set to position 2. The APR-UA Unit **requires** an AC adapter (ACA-UA Unit). If a CTA-BA Unit or the HFU-UA Unit and an APR-UA Unit are both installed, only one AC adapter is required.

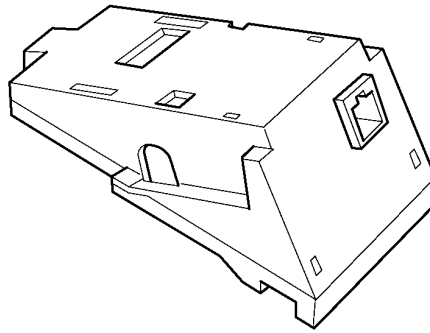

Figure 6-45: APR-UA Unit

Installing an APR-UA Unit on a Multiline Terminal

1. Unplug the telephone cord from the Multiline Terminal.
2. Prepare Multiline Terminal for adapter installation. Refer to *Section 9: Preparing Multiline Terminal for Adapter Installation*.
3. Plug the unit into the receptacle connector inside the base plate. Refer to *Figure 6-46: Attaching the Unit to the Multiline Terminal*.

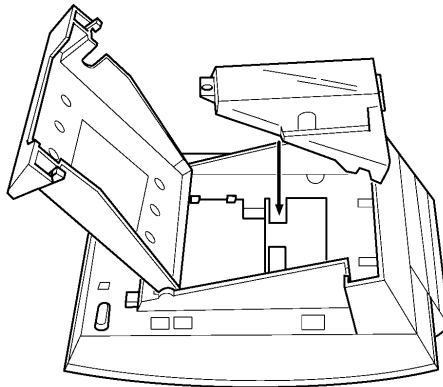

Figure 6-46: Attaching the Unit to the Multiline Terminal

4. Plug the cord of the ACA-UA Unit (AC adapter) into the jack on the APR-UA Unit. Lead the telephone cord out through the groove in the base as shown in *Figure 6-47: Leading the Telephone Cord out from the Unit*.

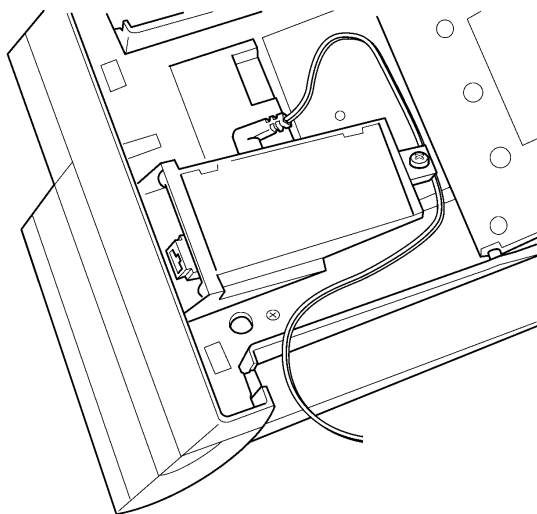

Figure 6-47: Leading the Telephone Cord out from the Unit

5. Close the base plate, lead the AC adapter cord out through the hole, and snap the cover in place.

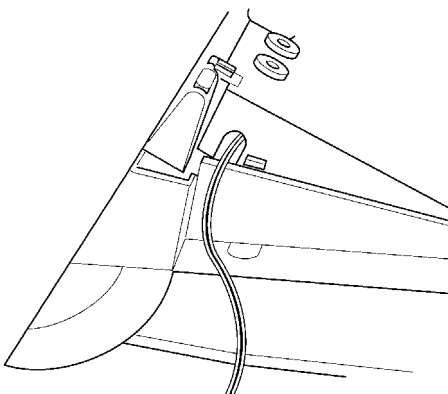

Figure 6-48: Closing the Base Plate Cover

6. Plug in the power cord on the AC adapter and the telephone cord in the jack.

Switch Settings

There are two switch settings on the APR-UA Unit.

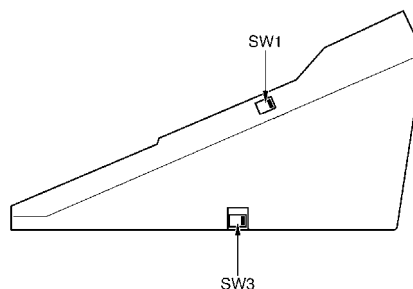

Figure 6-49: APR-UA Unit Switches

The following table lists the switch settings for SW1 and SW3.

Switch	Description
SW1-1	Do not use
SW1-2	A Single Line Telephone and Multiline Terminal are used alternately. (The Multiline Terminal and the APR-UA Unit share the same B1 channel.)
SW3-1	Sets impedance to 600 ohm for devices such as modems or facsimile machines
SW3-2	Used for complex impedance devices such as Single Line Telephones.

Connecting Cables on the APR-UA Unit

Plug the telephone cord from the Single Line Telephone into the modular jack on the APR-UA Unit.

Limit the cable length from the APR-UA Unit to the Single Line Telephone to a maximum of 15 metres.

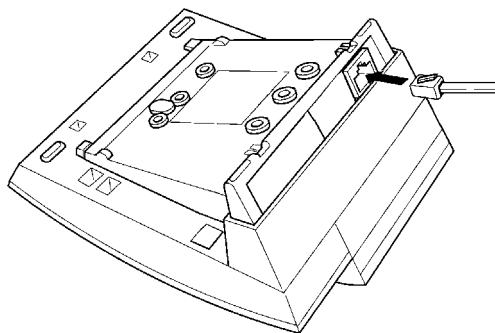

Figure 6-50: Connecting Cables on the APR-UA Unit

CTA-BA Unit (Computer Telephony Application)

Computer Telephony Application allows a DTU-type Multiline Terminal to be connected to a PC. The PC can then be used to perform all of the functions of the Multiline Terminal by using a TAPI compatible application software.

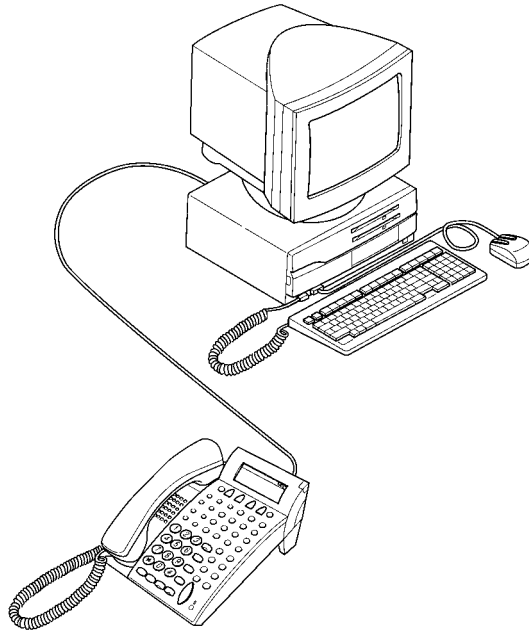

Figure 6-51: Attaching a Xen Multiline Terminal to a PC

The CTA-BA Unit is attached to the bottom of a DTU-type Multiline Terminal.

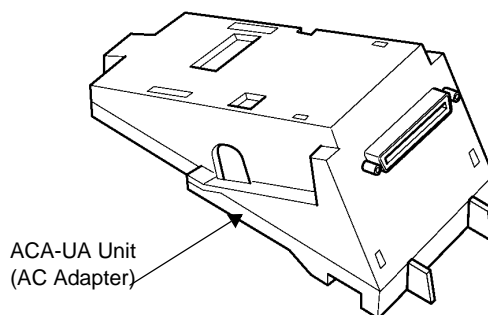

Figure 6-52: CTA-BA Unit

Installing the CTA-BA Unit

1. Unplug the telephone cord from the Multiline Terminal.
2. Prepare Multiline Terminal for adapter installation. Refer to *Section 9: Preparing Multiline Terminal for Adapter Installation*.

3. Plug the unit into the receptacle connector inside the base plate on the Multiline Terminal. Refer to *Figure 6-53: Attaching the Unit to the Multiline Terminal*.

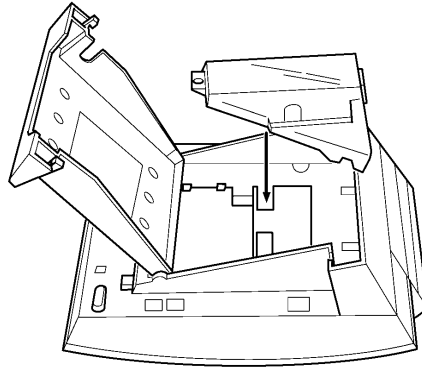

Figure 6-53: Attaching the Unit to the Multiline Terminal

4. Close the base plate.

Connecting the Cables on the CTA-BA Unit

Connect the RS-232C cable from the computer to the connector on the CTA-BA Unit as shown in *Figure 6-54: Connecting the RS-232C Cable to the CTA-BA Unit on the Multiline Terminal*.

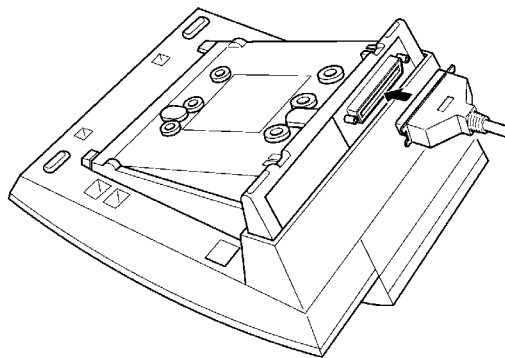

Figure 6-54: Connecting the RS-232C Cable to the CTA-BA Unit on the Multiline Terminal

Installing the Driver on the PC

Using the setup disk provided with the CTA-BA Unit install the driver onto your PC. Refer to the *CTA installation Guide* for instructions on installing CTA setup disks.

HFU-UA (WH) Unit (Handsfree Unit)

The Handsfree Unit provides full-duplex handsfree communication. Large areas may cause poor full-duplex operation. This unit comes with the handsfree adapter and an external microphone. With terminal upside down, facing from the bottom of the open cover, install this unit on the left side.

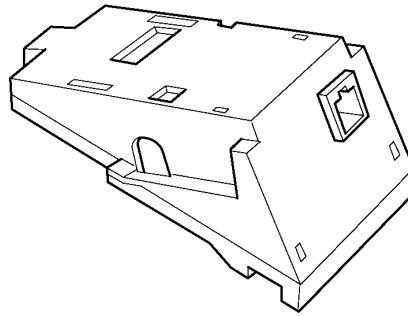

Figure 6-55: HFU-UA (WH) Unit

Installing an HFU-UA (WH) Unit on a Multiline Terminal

Refer to *Section 9: Installing an APR-UA Unit on a Multiline Terminal on page 1-151*. The instructions for installing these units are the same.

Installing the External Microphone

An external microphone can be installed on the HFU-UA (WH) Unit. These instructions apply to the external microphone supplied with the HFU-UA (WH) Unit. This microphone is equipped with a mute button.

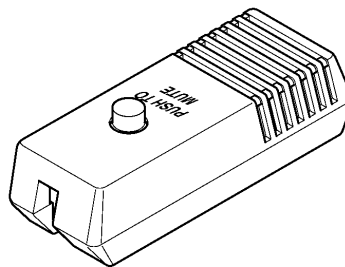

Figure 6-56: Microphone with Mute

1. Plug the microphone cord into the jack on the HFU-UA (WH) Unit as shown in *Figure 6-57: Attaching a Microphone to a Multiline Terminal*.

Note: The microphone should be at least 30 cm away from the Multiline Terminal, but not more than 1 metre.

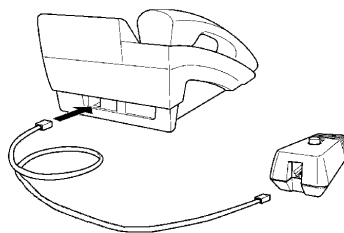

Figure 6-57: Attaching a Microphone to a Multiline Terminal

Switch Settings

The HFU-UA (WH) Unit uses two-position switches SW1 and SW2.

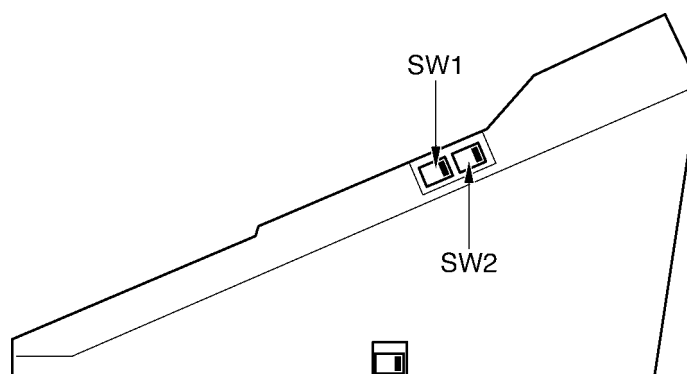

Figure 6-58: HFU-UA (WH) Unit Switches

The following table lists the SW1 and SW2 switch settings.

Table 6-3: HFU-UA (WH) Unit Switch Settings

SW1		SW2		Description
Position 1	Position 2	Position 1	Position 2	
OFF	ON	OFF	ON	Full Duplex (Default)
ON	OFF	OFF	ON	Half Duplex (6db mix ratio)
OFF	ON	ON	OFF	Half Duplex (12db mix ratio)
ON	OFF	ON	OFF	Half Duplex (18db mix ratio)

NOTE: Full Duplex: In some large areas or noisy locations half duplex should be used. There are limits to the echo cancelling ability of the HFU-UA.

Half Duplex: If voice clipping occurs, use a lower decibel setting.

This page is intentionally blank.

Installing ETW-Type Multiline Terminals

**SECTION 1
GENERAL
INFORMATION**

ETW-type Multiline Terminals can be installed on a Xen Alpha system providing inexpensive migration from other NEC key telephone systems. This chapter provides instructions for connecting these terminals to the Xen Alpha system.

 ETW-type Multiline Terminals are not available in New Zealand.

**SECTION 2
ETW-TYPE
MULTILINE
TERMINALS**

The following ETW-type Multiline Terminals can be connected to the Xen system.



ETW-8E-1A (SW) TEL



ETW-16C-1A (SW) TEL



ETW-16D-1A (SW) TEL

Terminal Update

Before ETW-type Multiline Terminals can be operated on a Xen Alpha system, the keypad may need to be changed. Replacement keypads and installation instructions are available for purchase from the NEC CNS ICP Service Department.

Modular Terminal Connections

Connecting Multiline Terminals and SLT Adapters.

When connecting ETW-type Multiline Terminals or SLT Adapters to the MDF or IDF, individually twisted 1-pair cabling must be used. Refer to *Figure 7-1: Modular Terminal Connections for Multiline Terminals* – for an illustration of connections.

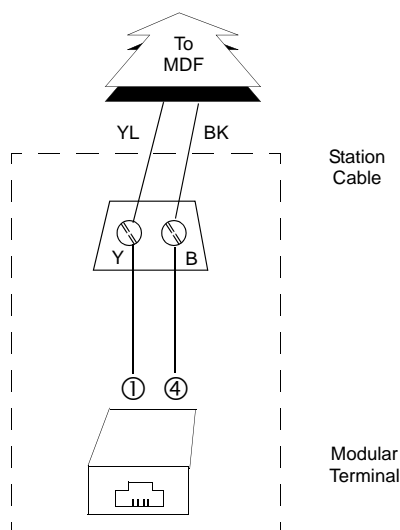

Figure 7-1: Modular Terminal Connections for Multiline Terminals

Attach a Multiline Terminal to the System

1. Plug a telephone cord into the modular jack on the bottom side of the Multiline Terminal.
2. Lead the cord out through the cord groove as shown in *Figure 7-2: Connecting an ETW-Type Multiline Terminal* – .

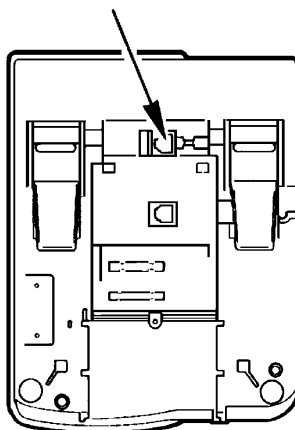

Figure 7-2: Connecting an ETW-Type Multiline Terminal

Installing Optional Terminal Equipment

SECTION 1
SLT(1)-U13
ADP (SINGLE
LINE
TELEPHONE
ADAPTOR)

The Single Line Telephone adaptor provides an interface for Single Line Telephones and other similar devices from an ESI ETU channel. This adaptor can be connected to any ESI port.

Connecting the SLT(1)-U13 ADP to the System

1. Connect one end of the RJ-11 to the ESI port on the KSU and one end to the jack on the SLT adaptor marked **ESI**.
2. Connect one end of a second RJ-11 to the jack marked **TEL** on the SLT adaptor and the other end to the Single Line Telephone.

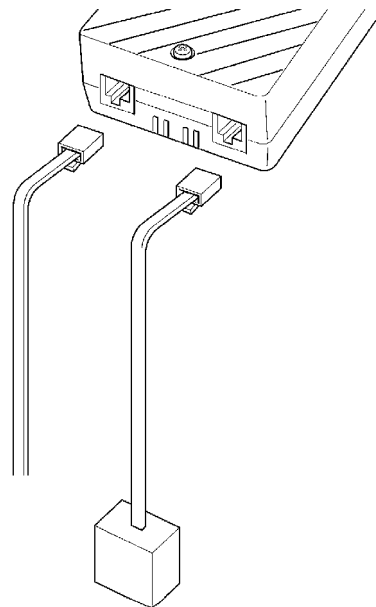
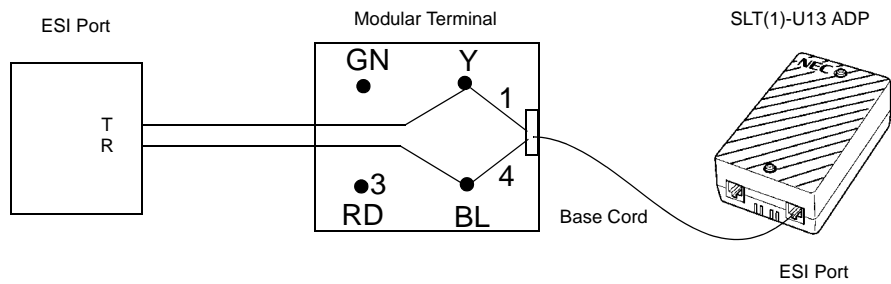
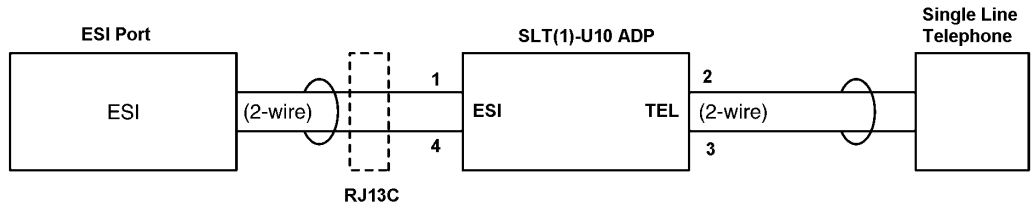

Figure 8-1: Connecting a Single Line Telephone to the System using an SLT(1)-U13 ADP



Modular Terminal Connections



Single Line Telephone Connections

Figure 8-2: Connecting the SLT(1)-U13 ADP

Wall Mounting the SLT(1)-U13 ADP

1. Remove the two screws from the top to open the SLT adapter as shown in *Figure 8-3: Removing the Screws from the SLT(1)-U13 ADP* .

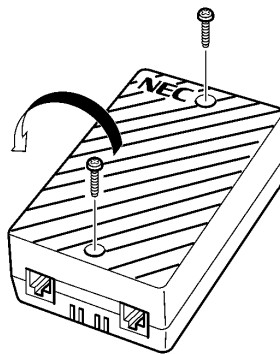

Figure 8-3: Removing the Screws from the SLT(1)-U13 ADP

- Using the two provided wood screws, attach the unit to the wall. Close the unit and secure with the two screws that were previously removed.

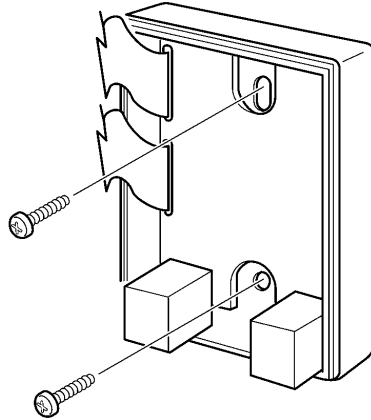

Figure 8-4: Attaching the SLT(1)-U13 ADP to the Wall

This page is intentionally blank.

SECTION 1 INTRODUCTION

When the system is initially installed, it is fully operational with the preset default settings. Users can customise the system by changing system programming values using either telephone programming or PC programming. This chapter provides detailed instructions for programming from a telephone.

Telephone programming is designed primarily for experienced users. Therefore, if you are a first-time user, we strongly recommend that you use PC programming instead of telephone programming.

It should be noted that only one telephone can be in programming mode at a time. If another telephone user attempts to access programming mode, that telephone is blocked from entering programming mode.

The following Multiline telephone types can be used as programming telephones.





- | | |
|--|--|
| <input type="checkbox"/> DTB-16D-1A(WH) TEL | <input type="checkbox"/> DTR-8D-1A(BK)/(WH) TEL |
| <input type="checkbox"/> DTU-8D-1A(BK)/(WH) TEL | <input type="checkbox"/> DTR-16D-1A(BK)/(WH) TEL |
| <input type="checkbox"/> DTU-16D-1A(BK)/(WH) TEL | <input type="checkbox"/> DTR-32D-1A(BK)/(WH) TEL |
| <input type="checkbox"/> DTU-32D-1A(BK)/(WH) TEL | |

-  Only telephone ports 1 and 2 (normally extensions 10 or 11) can be used to enter telephone program mode.

SECTION 2 ENTERING PROGRAMMING MODE

Once you have entered into programming mode you can access the various programming functions by either using the navigational keys or by manually entering the function number (e.g., 001-1, 002, 220, etc.). The function number provides access to the area you want to program. *Table 9-1: Navigational Keys for Telephone Programming* provides a list of keys you can use to navigate the system. The following tables provide a complete list of all of the programming functions.

To program the system using a telephone, you must first enter programming mode.

1. Press  .
2. Press  .
3. Dial    . The display shows the information for function number 001-1.

P001 SYS SETUP 1
987654321

Programming Guidelines

When programming you should understand the following:

- ❑ The telephone display indicates the function number, function group name and default settings.

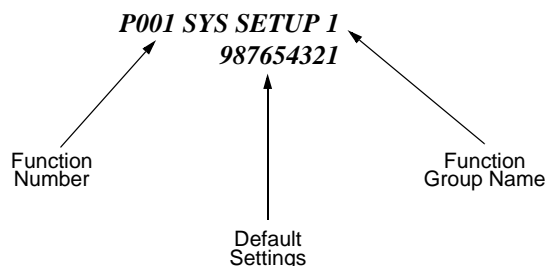

- ❑ When function numbers are grouped (e.g., 001-1 ⇒ 001-9), all of the function numbers are displayed at the same time. To change between the default value and the alternate value, press the dial pad key that corresponds to the last digit of the function number you are changing.

For example:

When you access the function number for 001-1~001-9. The system displays:

P001 SYS SETUP
1
987653

If you want to change the programming value for Function 001-4, press  on the dial pad. When “-” appears on the display, you have changed to the alternate programming value for that function. The default value is displayed if this is the first time you are using the system. If the system has been previously programmed, the alternate value may be displayed instead of the default value. It is important to note that the series of numbers is displayed in descending order (987654321).

















- ❑ The following navigational keys are used. Note that the DTU-Type telephones do not have a SPD key. The DTB-Type telephones use the  and  keys to perform many of the same functions that the  key does on the DTU-Type telephones. Throughout this chapter any differences are noted where necessary.

Table 9-1: Navigational Keys for Telephone Programming

Key	Description
 	Returns to the previous function. Repeatedly pressing this key allows you to scroll backward through the function numbers.
 	Forwards to the next function. Repeatedly pressing this key allows you to scroll forward through the function numbers.
 	Clears the display allowing you to enter a function number using the dialpad.
 	Exits programming mode and returns the telephone to normal operation.
 	The  key on DTB-Type Multiline telephones and  on DTU-Type Multiline telephones is used to enter a dash into a telephone number
 	Clears data that was entered using the dialpad.

- ❑ The line keys (feature access/one-touch) are numbered differently for the DTB-type and DTU-Type Multiline telephones. The diagram below illustrates these differences. It is important to keep these differences in mind when programming.

When making use of P001-8 (one-touch key duplication), note the difference in location between the one-touch keys and feature access keys between the different terminals.

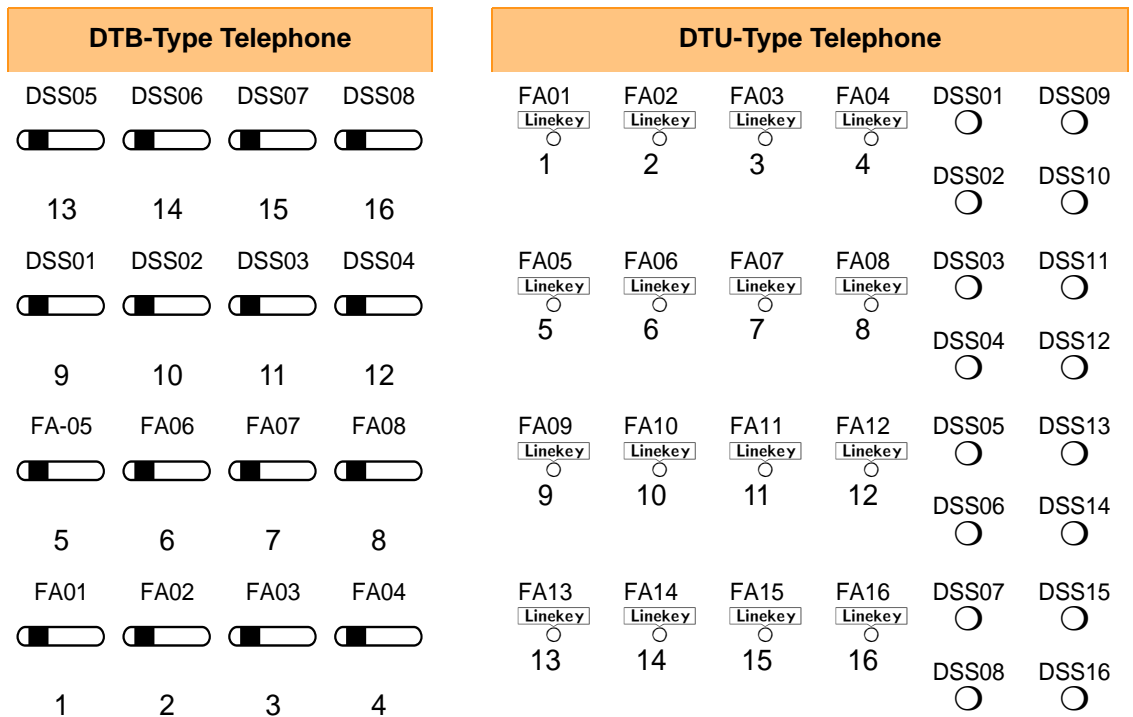

FA = Feature Access Key, DSS = Direct Station Select Key

Typically, line keys 1-6 are used for trunk line assignment. However, any unused line keys can be used as feature access keys by disabling them in P109.

SECTION 3 PROGRAMMING FUNCTIONS

The table provides a complete list of all of the programming functions. These are listed in order by function number. The table consists of four columns, a brief explanation of each column is listed below.

Function Number

Lists the number used by the system to access the programming functions.

Function Name/Telephone Display

Lists the function name and shows how the function appears in the display of the telephone. Since there is limited space in the telephone display, the functions are abbreviated and will not match the function name. To distinguish the function name from the telephone display, the following font is used to indicate the display:

Display Sample Typeface. The telephone display typically consists of two lines. The first line is the abbreviation and the second line is the default setting. If your system has been previously programmed, the number on your display may be different from the one provided in the table.

Description

Provides a brief explanation of the function.

Programming Values

Lists the programmable options for the function. Note that the default values are displayed in bold typeface.

System Wide Settings





Programming To change a default setting for function numbers 001, 002, 018, 019 and 060
Note: dial the number that corresponds to the setting position you want to change (1-9 or 0, as appropriate). For example, to change the setting for 001-1, dial [1] to toggle its setting between the two values

Function Number	Function Name and Telephone Display	Description	Programming Values
001-1	Internal Call Notification <i>P001 SYS SETUP 1</i> 09-765432-	Used to indicate how users are notified of internal calls. If Voice is selected, users can voice announce calls. If Signal Tone is selected, the system sends an audible tone to the called party.	1 = Voice - = Signal Tone
001-2	Speed Dial Assignment 09-765432-	Used to assign the number of speed dial memory locations used for system (common) speed dialling and personal (individual) speed dialling.	2 = 80 System/20 Personal - = 400 Slots/0 Personal (200 Release 2.0 and below)
001-3	Not used		
Programming Note: On DTB-Type telephones, any unused line keys can be assigned as one-touch keys.			
001-4	Ringing Transfer 09-765432-	Used to enable or disable ringing transfer for external calls. If enabled, the called party hears ringing. If disabled, the called party does not hear ringing.	4 = Enabled - = Disabled
001-5	Not Used		
001-6	Trunk Line Direct Access 09-765432-	Used to assign how an outside line is accessed. If enabled, the user can press the designated line to directly access the outside line. If disabled, the user must press the designated line key and then go off-hook (within 3 sec.) to access an external line.	6 = Enabled - = Disabled







Function Number	Function Name and Telephone Display	Description	Programming Values
001-7	One-Touch Key Direct Access for Outgoing Calls 09-765432-	Used to assign how a one-touch key accesses an outside line. If enabled, the user can press the one-touch key, the outside line is directly accessed and the number is dialed. If disabled, the user must first manually access the outside line before pressing the one-touch key.	7 = Enabled - = Disabled
001-8	One-Touch Key Duplication Assignment 09-765432-	This feature is used to enable duplication of one-touch/feature keys. If enabled, the one-touch/feature access keys assignment made on Ports 01 or 02 are duplicated to all other telephones in the system. Note: Refer to Table 7-1.	8 = Enabled - = Disabled
<p>Programming Note: This function can only be set from the telephone attached to port 1 or 2 (attendant position telephone). When using the DTB-16D-1A TEL telephones, any unused line keys can be assigned as one-touch/feature access keys. When using DTU-Type telephones, the DTU-32D-1A TEL must be used to set this feature and the one-touch keys (not the line keys) must be used to set one-touch key duplication.</p>			
001-9	Single Line Telephone Hookflash Assignment 09-765432-	Used to assign how the hookflash is used on a single line telephone.	9 = Used for Hold - = Used for Hookflash
001-0	General Purpose Relay Assignment 09-765432-	Assigns the function of General Purpose Relay on the Mainboard to either External Paging Speaker Control or External Ringer Control.	0 = External Ringer Control - = External Paging Control
002-1	Music Source for Music On Hold <i>P002 SYS SETUP 2</i> 0-87- 543 --	Used to indicate whether the system is connected to an external source for Music on Hold.	1 = Connected - = Not Connected
002-2	External Speaker Connection 0-87- 543 --	Used to indicate if an external speaker is connected to the system.	2 = Connected - = Not Connected
002-3	Call Notification Using External Speakers 0-87- 543 --	Used to assign if an audible tone is sent from the external speaker when call notification is used.	3 = Enabled - = Disabled

Function Number	Function Name and Telephone Display	Description	Programming Values
002-4	All Call Paging Tone 0-87-543--	Used to enable or disable an audible tone during call paging.	4 = Enabled (Tone Sent) - = Disabled
002-5	Barge-In Notification Tone 0-87-543--	Used to enable or disable an audible tone when barging into a conversation.	5 = Enabled (Tone Sent) - = Disabled (No Tone Sent)
002-6	Background Music Source 0-87-543--	Indicates whether a background music source is connected to the system.	6 = Connected - = Not Connected
002-7	Time Format for Telephone Display 0-87-543--	Selects the format used when displaying time on the telephone.	7 = 12 Hour (12:00 a.m. – 11:50 p.m.) - = 24 Hour (0:00 – 23:59)
002-8	Privacy Release 0-87-543--	Assigns if extensions are required to enter a feature code to enable another extension entering a conversation by pressing a line key.	8 = Disabled (feature code required) - = Enabled (feature code not required)
002-9	Station Message Detail Recording 0-87-543--	Enables or disables Station Message Detail Recording (SMDR). SMDR provides detailed telephone usage records.	9 = Enabled - = Disabled
002-0	Station Camp-on Selection 0-87-543--	Specifies whether or not Station Camp-on is allowed in the system (i.e., ring transfer to a busy station). This applies to MLT ports only. SLT ports 15 and 16 are always able to perform a Camp-on. When Camp-on is disabled, an attempt to ring transfer an external call to a busy station will leave the call on hold, on the originating station (line key remains flashing green).	0 = Yes - = No
003	Hold/Transfer Recall Warning Timer <i>P003 HOLD RECALL</i> 0	Sets the maximum time an external call can be placed on Non-Exclusive Hold or transferred, until a recall tone is generated.	0 = 1 minute 1 = 2 minutes 2 = 3 minutes 3 = 4 minutes 4 = No Limit (No warning indication sent)

Function Number	Function Name and Telephone Display	Description	Programming Values																				
004	Exclusive Hold / Transfer Recall Warning Timer <i>P004 EX-HOLD REC</i> 0	Sets the maximum time an external call can be placed on Exclusive Hold or transferred, until a recall tone is generated.	0 = 1 minute 1 = 2 minutes 2 = 3 minutes 3 = 4 minutes 4 = No Limit (No warning indication sent)																				
005	Automatic Redial Timer <i>P005 REDIAL TIME</i> 1	Used to set three parameters associated with the Automatic Redial feature. <i>Duration</i> indicates the amount of time the system continues to redial the number. <i>Wait Duration</i> is the amount of time the system waits between call attempts. <i>Number of Times</i> indicates the number of times the system redials to a busy number or when there is no answer.	<table border="1"> <thead> <tr> <th></th> <th>Call Duration</th> <th>Wait Duration</th> <th>Number of Times</th> </tr> </thead> <tbody> <tr> <td>0 =</td> <td>5 sec.</td> <td>5 sec.</td> <td>3</td> </tr> <tr> <td>1 =</td> <td>10 sec.</td> <td>30 sec.</td> <td>3</td> </tr> <tr> <td>2 =</td> <td>15 sec.</td> <td>60 sec.</td> <td>3</td> </tr> <tr> <td>3 =</td> <td>15 sec.</td> <td>90 sec.</td> <td>3</td> </tr> </tbody> </table>		Call Duration	Wait Duration	Number of Times	0 =	5 sec.	5 sec.	3	1 =	10 sec.	30 sec.	3	2 =	15 sec.	60 sec.	3	3 =	15 sec.	90 sec.	3
	Call Duration	Wait Duration	Number of Times																				
0 =	5 sec.	5 sec.	3																				
1 =	10 sec.	30 sec.	3																				
2 =	15 sec.	60 sec.	3																				
3 =	15 sec.	90 sec.	3																				
006	Hookflash Duration <i>P006 HOOKFLASH</i> 1	Used to specify the duration of Hookflash sent to the network. A hookflash can be generated by pressing the hookswitch on single line telephones or by pressing the Recall/Flash key on a multiline telephone.	<table border="1"> <tbody> <tr> <td>0 = 60 ms.</td> <td>5 = 600 ms.</td> </tr> <tr> <td>1 = 100 ms.</td> <td>6 = 800 ms.</td> </tr> <tr> <td>2 = 140 ms.</td> <td>7 = 1 sec.</td> </tr> <tr> <td>3 = 200 ms.</td> <td>8 = 1.5 sec.</td> </tr> <tr> <td>4 = 400 ms.</td> <td>9 = 2 sec.</td> </tr> </tbody> </table>	0 = 60 ms.	5 = 600 ms.	1 = 100 ms.	6 = 800 ms.	2 = 140 ms.	7 = 1 sec.	3 = 200 ms.	8 = 1.5 sec.	4 = 400 ms.	9 = 2 sec.										
0 = 60 ms.	5 = 600 ms.																						
1 = 100 ms.	6 = 800 ms.																						
2 = 140 ms.	7 = 1 sec.																						
3 = 200 ms.	8 = 1.5 sec.																						
4 = 400 ms.	9 = 2 sec.																						
007	Flexible Assignment of Attendant Call and Trunk Access Codes <i>P007 ACCESS CODE</i> -	Allows user to specify whether "9" or "0" is dialed for Attendant Call/Trunk Access.	- = Dial 0 for Line Access. Dial 9 for Attendant. 1 = Dial 0 for Attendant. Dial 9 for Line Access.																				
008	Call Forward No Answer Transfer Duration <i>P008 FWD NOANS</i> 0	Used to specify the duration of incoming intercom and CO/PBX calls before they are forwarded to another station number or external destination, when the called party does not answer.	<table border="1"> <tbody> <tr> <td>0 = 10 sec.</td> <td>3 = 25 sec.</td> </tr> <tr> <td>1 = 15 sec.</td> <td>4 = 30 sec.</td> </tr> <tr> <td>2 = 20 sec.</td> <td>5 = 60 sec.</td> </tr> </tbody> </table>	0 = 10 sec.	3 = 25 sec.	1 = 15 sec.	4 = 30 sec.	2 = 20 sec.	5 = 60 sec.														
0 = 10 sec.	3 = 25 sec.																						
1 = 15 sec.	4 = 30 sec.																						
2 = 20 sec.	5 = 60 sec.																						

Function Number	Function Name and Telephone Display	Description	Programming Values
009	Outgoing Call Line Selection <i>P009 OUTPUT LN</i> 2	Used to assign the type of line the system connects to when 0– (outside call access code) is used,  is pressed, or a one-touch key is pressed. If '0' programming value, is specified, the line key must be pressed to access a trunk line. If analog only or analog prioritised is selected, an analog trunk line is selected first. If ISDN prioritised is selected, an ISDN line is selected first.	0 = Manual Line Seizure Only 1 = Analogue Only 2 = Analogue Prioritised 3 = ISDN Prioritised
010	Outgoing Call Access Code for PBX <i>P010 PBX AC</i> 0–	Used to specify the code (number) dialled to access an outside line from a PBX.	Default value = 0 – (2 digit access code) Maximum digits = 6 (3 numbers and 3 pauses) Note: Press Answer Key for Pause.
Programming Note: To enter pauses in Function 010, press  on the DTB-Type telephone and  on the DTU-Type telephone. You cannot enter two consecutive pauses, there must be a number between each pause. Press  to clear the data.			
011	Background Music Destination <i>P011 BGM DESTIN</i> 1	Indicates where background music is heard.	0 = External Speaker 1 = Telephone Speaker 2 = External Speaker and Telephone Speaker 3 = Background Music Not Heard
012	Music On Hold Melody <i>P012 MSC ON HLD</i> 0	Used to select the melody used for the Music on Hold.	0 = "Je te veus" 1 = Minuet
014	Night Mode Start Time (Assignment 1) <i>P014 N MD TMI ST</i> □□:□□	Used to select the time of day the system switches from day mode to night mode.	Not Set Use 24 hour mode to set the time (00:00 – 23:59).
Programming Note: When setting the time for Functions 014⇒017, use line key 13 to move the cursor to the left and 16 to move the cursor to the right.			
015	Night Mode End Time (Assignment 1) <i>P015 N MD TMI ED</i> □□:□□	Used to select the time of day the system switches from night mode back to day mode.	Not Set Use 24 hour mode to set the time (00:00 – 23:59).
016	Night Mode Start Time (Assignment 2) <i>P016 N MD TM2 ST</i> □□:□□	Used to select the time of day the system switches from day mode to night mode.	Not Set Use 24 hour mode to set the time (00:00 – 23:59).

Function Number	Function Name and Telephone Display	Description	Programming Values
017	Night Mode End Time (Assignment 2) <i>P017 N MD TM2 ED</i> □□:□□	Used to select the time of day the system switches from night mode back to day mode.	Not Set Use 24 hour mode to set the time (00:00 – 23:59).
018-1	Night Mode – Monday <i>P018 NIGHT MODE</i> MONDAY:0	Used to assign night mode for Monday.	0 = Continuous Day Mode 1 = Night Mode Assignment 1 2 = Night Mode Assignment 2 3 = Continuous Night Mode (Holidays) Press Transfer to advance to next day setting. Exiting program mode will enter new data.
018-2	Night Mode – Tuesday <i>P018 NIGHT MODE</i> TUESDAY:0	Used to assign night mode for Tuesday.	
018-3	Night Mode – Wednesday <i>P018 NIGHT MODE</i> WEDNESDAY:0	Used to assign night mode for Wednesday.	
018-4	Night Mode – Thursday <i>P018 NIGHT MODE</i> THURSDAY:0	Used to assign night mode for Thursday.	
018-5	Night Mode – Friday <i>P018 NIGHT MODE</i> FRIDAY:0	Used to assign night mode for Friday.	
018-6	Night Mode – Saturday <i>P018 NIGHT MODE</i> SATURDAY:0	Used to assign night mode for Saturday.	
018-7	Night Mode – Sunday <i>P018 NIGHT MODE</i> SUNDAY:0	Used to assign night mode for Sunday.	
Programming Note:	When scrolling to the next day of the week, press  . It is important to note that programming values 1 and 2 are only available if 014 and 015 (Night Mode Assignment 1) or 016 and 017 (Night Mode Assignment 2) have been programmed. If you attempt to enter 1 or 2 when 014 – 017 have not been programmed, the system simply ignores the entry and continues to blink.		
019-1	Primary Hunt Number 10 <i>P019 PILOT</i> -----	Used to assign extension numbers 10⇒19 to Primary Hunt Number 10.	1 = Primary Hunt Number Valid – = Primary Hunt Number Invalid A hunt group consists of a series of telephone lines that are organised so that if the first line is busy the system hunts for the next line in the series that is available.

Function Number	Function Name and Telephone Display	Description	Programming Values
019-2	Primary Hunt Number 20	Used to assign extension numbers 20⇒29 to Primary Hunt Number 20.	2 = Primary Hunt Number Valid - = Primary Hunt Number Invalid
019-3	Primary Hunt Number 30	Used to assign extension numbers 30⇒39 to Primary Hunt Number 30.	3 = Primary Hunt Number Valid - = Primary Hunt Number Invalid
019-4	Primary Hunt Number 40	Used to assign extension numbers 40⇒49 to Primary Hunt Number 40.	4 = Primary Hunt Number Valid - = Primary Hunt Number Invalid
019-5	Primary Hunt Number 50	Used to assign extension numbers 50⇒59 to Primary Hunt Number 50.	5 = Primary Hunt Number Valid - = Primary Hunt Number Invalid
020	Restricted Dialling – Table 1 <i>P020 RESTR DY T1</i> 01: □□□□□□□□	Used to record numbers that users are not allowed to dial (e.g., long distance numbers), while the system is in Day mode.	Enter the numbers (maximum 8 digits) that have restricted dialling.
021	Restricted Dialling – Table 2 <i>P021 RESTR DY T2</i> 01: □□□□□□□□	The table allows eight numbers to be entered and the maximum length of each number is eight digits.	
022	Authorised Dialling – Table 1 <i>P022 ALLOW DY T1</i> 01: □□□□□□□□	Used to record numbers that users are permitted to dial (e.g., certain long distance numbers), while the system is in Day mode. The table allows eight numbers to be entered and the maximum length of each number is eight digits.	Enter the numbers (maximum 8 digits) that have authorised dialling.
023	Authorised Dialling – Table 2 <i>P023 ALLOW DY T2</i> 01: □□□□□□□□		
Programming Note:	<p>When setting the restricted dial number for Functions 020⇒023, use line keys 13 to move the cursor to the left and 16 to move the cursor to the right.</p> <p>To advance to the next location where the restricted dial numbers can be entered, press .</p> <p>To enter an “X”, which indicates to the system to use any number (0⇒9, *, #) where X is found, press . An “s” should appear in the second line of the display to indicate shift mode. To enter an “X”, which indicates a wildcard number, press .</p> <p>To enter “N”, which indicates numbers 2⇒9, press . To enter an * or #, press  or  (you must be in shift mode).</p>		

Function Number	Function Name and Telephone Display	Description	Programming Values
024	Print Format <i>P024 PRN FORMAT</i> 1	Used to indicate how the number is printed on the Station Message Detail Report. The options include printing the entire number or just printing the prefix and masking the last four digits.	0 = Mask last 4 digits 1 = Print entire number
025	Baud Rate to Printer <i>P025 PRN SPEED</i> 4	Used to assign the baud rate for outputting to the printer.	0 = 1200 bps 3 = 9600 bps 1 = 2400 bps 4 = 19200 bps 2 = 4800 bps 5 = 38400 bps
026	Stop Bit for Printer <i>P026 PRN CONTROL</i> 1	Used to assign the stop bit for outputting to the printer.	0 = 2 Stop Bit 1 = 1 Stop Bits
028	Automatic Disconnect Timer <i>P028 AUTO DISCON</i> 1	Specifies the maximum time a trunk transfer call (including CFE) will remain in place before being forcibly disconnected. A pip tone will be heard by both parties 30 seconds before the trunks are released by the system.	0 = 30 minutes 1 = 1 hour 2 = 2 hours 3 = 3 hours
029	SMDR recording call type <i>P029 SMDR TYPE</i> 1	Specify which types of calls are to be printed by the SMDR facility.	0 = All Calls 1 = Outgoing calls only 2 = Incoming calls only
030	Restricted Dialling – Table 1 <i>P030 RESTR NT T1</i> 01: <input type="text"/> <input type="text"/> <input type="text"/> <input type="text"/> <input type="text"/> <input type="text"/> <input type="text"/> <input type="text"/>	Used to record numbers that users are not allowed to dial (e.g., long distance numbers), while the system is in Day mode.	Enter the numbers (maximum 8 digits) that have restricted dialling.
031	Restricted Dialling – Table 2 <i>P031 RESTR NT T2</i> 01: <input type="text"/> <input type="text"/> <input type="text"/> <input type="text"/> <input type="text"/> <input type="text"/> <input type="text"/> <input type="text"/>	The table allows eight numbers to be entered and the maximum length of each number is eight digits.	
032	Authorised Dialling – Table 1 <i>P032 ALLOW NT T1</i> 01: <input type="text"/> <input type="text"/> <input type="text"/> <input type="text"/> <input type="text"/> <input type="text"/> <input type="text"/> <input type="text"/>	Used to record numbers that users are permitted to dial (e.g., certain long distance numbers), while the system is in Day mode. The table allows eight numbers to be entered and the maximum length of each number is eight digits.	Enter the numbers (maximum 8 digits) that have authorised dialling.
033	Authorised Dialling – Table 2 <i>P033 ALLOW NT T2</i> 01: <input type="text"/> <input type="text"/> <input type="text"/> <input type="text"/> <input type="text"/> <input type="text"/> <input type="text"/> <input type="text"/>		

Function Number	Function Name and Telephone Display	Description	Programming Values
034	Voice Mail/SLT Selection <i>P034 VMI CONNECT</i> -	Specify whether or not the SLI(2)-B13 ETU ports are connected to an external voice mail system. When set to Yes, both ports provide analogue voice mail integration signalling.	- = No 1 = Yes
035	Voice Mail DTMF Delay Timer Selection <i>P035 VMI DELAY</i> 1	Specify the delay after off-hook before DTMF tones are sent to the external voice mail ports.	0 = 0 sec. 5 = 5.0 sec. 1 = 1.0 sec. 6 = 6.0 sec. 2 = 2.0 sec. 7 = 8.0 sec. 3 = 3.0 sec. 8 = 10.0 sec. 4 = 4.0 sec. 9 = 15.0 sec.
036	Voice Mail DTMF Duration /Interdigit Time Selection <i>P036 VMI DTMF</i> 0	Specify the DTMF signal duration and interdigit time for digits sent to the external voice mail ports.	0 = 100/70 msec. 1 = 400/100 msec.
037	Voice Mail Digit Prefix Assignment <i>P037 VMI PREFIX</i>	Assign the digits which will prefix the extension number when a call is answered by the external voice mail system.	Up to 4 digits (0~9, *, #) Default = Not Assigned
038	Voice Mail Message Set/ Cancel Code Assignment <i>P038 VMI CODES</i> 01:641	Specify the access codes used to set and cancel message waiting indication.	Default: 1: MW Set = 641 2: MW Cancel = 642
039	Voice Mail Pilot Number <i>P039 VM PILOT</i> -	Enter the extension number of the voice mail pilot. This may refer to the internal voice mail card or an external system connected via voice mail integration.	Digits 0 ~ 9 Default = Not Specified

Function Number	Function Name and Telephone Display	Description	Programming Values
060-1	ISDN Setup 1- MSN or Indial Service <i>P060 ISDNI SETUP</i> 4321	Specifies whether the numbering of the BRI ISDN services connected to the system are part of a 100 number indial range or a smaller number range.	1= MSN Mode – = Indial Mode -100 sequential numbers Indial -The last 2 digits of an incoming number is used for matching in P155/156 & P066/067. MSN - The ISDN Interface numbers excluding area code are assigned to an index number in P065.This index number (01⇒16) is then used for matching incoming calls in P155/156.Indial reference for MSN Mode is index number 01⇒16 in P066/067.
060-2	ISDN Setup 1 - Malicious Call Trace <i>P060 ISDNI SETUP</i> 4321	Specifies whether the BRI ISDN service is able to send a Malicious Call Trace (MCT) to the Network. Note: ISDN MCT must be enabled by the service provider and system programming for feature to function.	2 = MCT enabled – = MCT disabled
060-3	ISDN Setup 1 - Connection Type <i>P060 ISDNI SETUP</i> 4321	Specifies for BRT interface (Trunks 3 & 4) the type of connection (Point to Point or Point to Multipoint).	3 = Point to Multipoint – = Point to Point
060-4	ISDN Setup 1 - Card Type <i>P060 ISDNI SETUP</i> 4321	Specifies if BRT card is of the new or old type .A new card is identified by either Lot No 122B or higher or marked with a label EA-6795.	4 = New BRT Card – = Old BRT Card

Function Number	Function Name and Telephone Display	Description	Programming Values
061-1	ISDN Setup 2 – MSN or Indial Service <i>P061 ISDN2 SETUP</i> 4321	Specifies whether the numbering of the BRI ISDN services connected to the system are part of a 100 number indial range or a smaller number range.	1 = MSN Mode – = Indial Mode - 100 Indial -The last 2 digits of an incoming number is used for matching in P155/156 & P066/067. MSN - The ISDN Interface numbers excluding area code are assigned to an index number in P065.This index number (01⇒16) is then used for matching incoming calls in P155/156.Indial reference for MSN Mode is index number 01⇒16 in P066/067.
061-2	ISDN Setup 2 – Malicious Call Trace <i>P061 ISDN2 SETUP</i> 4321	Specifies whether the BRI ISDN service is able to send a Malicious Call Trace (MCT) to the Network. Note: ISDN MCT must be enabled by the service provider and system programming for feature to function.	2 = MCT enabled – = MCT disabled
061-3	ISDN Setup 2 – Connection Type <i>P061 ISDN2 SETUP</i> 4321	Specifies for BRT interface (Trunks 5 & 6) the type of connection (Point to Point or Point to Multipoint).	3 = Point to Multipoint – = Point to Point
061-4	ISDN Setup 2 – Card Type <i>P061 ISDN2 SETUP</i> 4321	Specifies if BRT card is of the new or old type .A new card is identified by either Lot No 122B or higher or marked with a label EA-6795.	4 = New BRT Card – = Old BRT Card
065	ISDN Number Assignment for MSN Mode <i>P065 ISDN TABLE</i> 01=	Assigns up to 16 ISDN numbers to be used as DID or GDN numbers through the system. This data applies only when this system is set to MSN mode (1, 2 or 8 numbers), not Indial mode (100 numbers).	ISDN TABLE 01 = <input type="checkbox"/> <input type="checkbox"/> <input type="checkbox"/> <input type="checkbox"/> <input type="checkbox"/> <input type="checkbox"/> <input type="checkbox"/> <input type="checkbox"/> 02 = ↓ 16 = Area code not required. If P060 = indial mode, then P155/156 use last 2 digit indial number matching If P060 = MSN mode, then P155/156 & P066/067 use index number 01⇒16 data.

Function Number	Function Name and Telephone Display	Description	Programming Values
066	DID Number Assignment to Station Port (Day mode) <i>P066 DID DAY</i> 00=	Assigns a Station port number to each Indial number for Day mode ringing. Note: Last 2 digit matching only.	Ports 01⇒14 = MLT Ports 15⇒16 = SLT Ports 17⇒18 = VMS Ports 19⇒20 = UCD Indial last 2 digits (00⇒99) Default: Not Assigned
067	DID Number Assignment to Station Port (Night Mode) <i>P067 DID NIGHT</i> 00=	Assigns a Station port number to each Indial number to Night mode ringing. Note: Last 2 digit matching only.	Ports 01⇒14 = MLT Ports 15⇒16 = SLT Ports 17⇒18 = VMS Ports 19⇒20 = UCD Indial last 2 digits (00⇒99) Default: Not Assigned
070	VRS Message Recording Time Selection <i>P070 VRS LENGTH</i> 0	Specify the length of each VRS message. increasing the length of the messages reduces the number of message which can be recorded. Changing this setting results in the loss of any existing recorded messages.	0 = 30 seconds x 8 messages 1 = 60 seconds x 4 messages 2 = 120 seconds x 2 messages
071	VRS Automatic Answer (Day) Selection <i>P071 VRS DAY</i> 0	Selects Automated Attendant or Automatic Answer operation for Day Mode.	0 = No VRS Answer 1 = Automated Attendant 2 = Automatic Answer
072	VRS Automatic Answer (Night) Selection <i>P072 VRS NIGHT</i> 0	Selects Automated Attendant or Automatic Answer operation for Night Mode.	0 = No VRS Answer 1 = Automated Attendant 2 = Automatic Answer
073	VRS Automatic Answer (Holiday) Selection <i>P073 VRS HOLIDAY</i> 0	Selects Automated Attendant or Automatic Answer operation for Holiday Mode.	0 = No VRS Answer 1 = Automated Attendant 2 = Automatic Answer
074	Not used.		
075	Not used.		
076	Automatic Answer Delay Time Assignment <i>P076 ANS DELAY</i> 04	Assigns the delay time before an incoming call is answered by the Automatic Answer feature.	00⇒99 seconds Default = 04 seconds
077	Automated Attendant Follow-on Message Assignment <i>P077 AA FLW MSG</i> -	Assigns the use of the follow-on message during an Automated Attendant answered call.	1 = Play Follow-on Message - = Don't Play Follow-on Message

Function Number	Function Name and Telephone Display	Description	Programming Values
078	Automated Attendant Answer Delay Time Assignment <i>P078 AA ANSDELAY</i> <i>04</i>	Assigns the delay time before an incoming call is answered by the Automated Attendant feature.	00⇒99 seconds Default = 04 seconds
079	Automated Attendant PBR Release Timer selection <i>P079 AA PBR TIME</i> <i>10</i>	Specifies the duration of the Second Dial Tone heard at the end of an Automated Attendant message. During this time, the PBR is activated to receive digits dialed by the caller.	00⇒99 seconds Default = 10 seconds 00 = No second dial tone. If PBR card is present and PBR time is set to 00, the PBR is always activated to received digits during AA message.
Programming Note: When setting P079 to the value of 00 seconds, the PBR remains active during the AA message.			
080	Automated Attendant Delay Ringing Time Selection <i>P088 AA DELAY RG</i> <i>00</i>	Selects the time before an Automated Attendant transferred call changes back into a ringing trunk call at all ring assigned stations.	00⇒99 seconds, where 00 = Infinity Default: 00 = infinity
081	Automated Attendant No Answer Disconnect Time Selection <i>P081 AA NA DISC</i> <i>05</i>	Specifies the time before disconnecting an unanswered Automated Attendant transferred or ringing call.	00⇒99 minutes, where 00 = Infinity Default: 05 minutes
082	Automated Attendant Follow-on Message Time Selection <i>P082 AA FLW TIME</i> <i>60</i>	Specifies the interval at which the follow-on message should be played during an unanswered Automated Attendant call.	00⇒99 seconds, where 00 = Infinity Default: 60 seconds
083	Automated Attendant No Digit Detect Selection <i>P083 AA NO DIGIT</i> <i>1</i>	Determines whether to process or release a call if no digit has been dialed in response to the Automated Attendant message.	1 = Process Call – = Release Call
084	Automated Attendant Access Code Assignment <i>P084 AA ACC CODE</i> <i>0 = –</i>	Assigns a station number to each Automated Attendant Access Code 0⇒9. Dialling this access code after/during the Automated Attendant message causes the specified station to ring. Note: Requires PBR card to function.	Access Codes = 0⇒9 Valid entry is Station No. = 10⇒59 Default: Not Assigned

Function Number	Function Name and Telephone Display	Description	Programming Values
085	Automated Attendant Hold Tone Selection <i>P085 AA HOLDTONE</i> 1	Selects whether the caller hears Ringback Tone or Music On Hold after the Automated Attendant message has finished playing.	1 = Ringback Tone (RBT) – = Music On Hold (MOH)
087	ACR Digit Entry <i>P087 ACR DIGITS</i> 1 – 000 = 000	Assigns the dialled digits which are to be analysed by the ACR facility. Up to 128 entries of 8 digits each can be entered into each of the two ACR tables.	Digits 0⇒9, *, #, X=0⇒9, P=0⇒7, N=8⇒9 Default: Tables 1 and 2, entry 000=000, Entries 001⇒127 = blank Note: 000=Emergency (in Australia)
088	ACR Digits Allow/Deny Assignment <i>P088 ACR ALLOW</i> 1 – 000 = 1	Assigns whether a number matched in the ACR table is allowed to be dialled or is to be restricted.	– = Denied 1 = Allowed
089	ACR Trunk Priority Assignment <i>P089 ACR trunk</i> 1 – 000 = 3	Specify for each ACR number which type of trunk is to be seized. In priority mode, the system moves from one trunk type to the other in order to find a free trunk. Otherwise the system will return busy if the specified trunk type is not available.	0 = ISDN Only 1 = PSTN Only 2 = ISDN Priority 3 = PSTN Priority
090	ACR Delete Digits Assignment <i>P090 ACR DEL</i> 1 – 000 = 0	Specify for each ACR number the number of digits (max. 8), which are to be deleted from the start of that number when it is dialled.	0⇒8 Default: All Entries 0
091	ACR Add Digits <i>P091 ACR ADD</i> 1 – 000 = –	Specify for each ACR number the string of digits (max. 8) that are to be added to the front of the dialled number after any deletion has occurred.	Digits 0⇒9, *, #, Pause(P), HookFlash(H) Default: All Entries Blank
092	UCD Group 1 Agent Assignment <i>P092 UCD1 GROUP</i> 00 = –	Assigns the 16 agent numbers for UCD Group 1. Entry 00 must be assigned with a number (eg. 1) for the group to be active.	Station No.: 10⇒59 Default: Not Assigned
093	UCD Group 2 Agent Assignment <i>P093 UCD2 GROUP</i> 00 = –	Assigns the 16 agent numbers for UCD Group 2. Entry 00 must be assigned with a number (eg. 2) for the group to be active.	Station No.: 10⇒59 Default: Not Assigned

Function Number	Function Name and Telephone Display	Description	Programming Values
094	UCD Greeting Message <i>P094 UCD ANS MSG</i> --	Assigns the use of the greeting message to each of the UCD groups.	1 = Answer with UCD VRS Message - = No UCD VRS message
095	UCD Follow-on Message <i>P095 UCD FLW MSG</i> --	Assigns the use of the follow-on message to each of the UCD groups.	1 = Play VRS Follow-on Message - = No Follow-on Message
096	ACR Mode of Operation <i>P096 ACR MODE</i> 1	Specify whether or not ACR is displayed and special dial tone is produced when an outside call is initiated on a station assigned with ACR.	1 = Display ACR - = Don't Display ACR

Trunk Programming

Programming To change the default setting for a trunk port, dial the 1 digit number that corresponds to the trunk you want to change (1 to 6, as appropriate). For example, to change the setting for trunk Port 1, dial "1". Depending on the function number, dialling the port number will either toggle its setting between two values or, where more than two values are available, will cause that setting to flash. When the setting flashes, you are required to enter a third digit, this being the new programming value (0 to 9, as appropriate). Port numbers are shown in descending order, with Port 01 on the right-hand side of the display.

Note:

Table 9-2: Trunk Programming Functions

Function Number	Function Name and Telephone Display	Description	Programming Values
101	Telephone Number Display for Trunk Line 1 <i>P101 LN1 TEL NO</i>	Used to assign the trunk line telephone number that is displayed when making and answering trunk line calls.	Not Assigned Maximum of 13 digits.
102	Telephone Number Display for Trunk Line 2 <i>P102 LN2 TEL NO</i>		
103	Telephone Number Display for Trunk Line 3 <i>P103 LN3 TEL NO</i>		
104	Telephone Number Display for Trunk Line 4 <i>P104 LN4 TEL NO</i>		
105	Telephone Number Display for Trunk Line 5 <i>P105 LN5 TEL NO</i>		
106	Telephone Number Display for Trunk Line 6 <i>P106 LN6 TEL NO</i>		
107	Trunk Line Type <i>P107 TRUNK TYPE</i> 654321	Used to indicate the trunk line type; from a Central Office or from a PBX.	1 = Central Office Line – = PBX Line
108	Trunk Line Function <i>P108 TRUNK STS</i> 654321	Used to indicate which trunk is to be set for incoming calls only.	1 = Allows Outgoing/Incoming Calls – = Incoming calls only
109	Trunk Line Dialling Type <i>P109 CO LN SLCT</i> 111111	Used to indicate the type of dialling; Dial Pulse (10 pps/20 pps), Dual Tone Multifrequency, ISDN, or uninstalled. DP = Rotary Dial DTMF = Touchtone ISDN = Integrated Services Digital Network	0 = Uninstalled 1 = Dual Tone Multifrequency (DTMF) or ISDN 2 = Dial Pulse (DP) 10 pps 3 = Dial Pulse (DP) 20 pps

Table 9-2: Trunk Programming Functions (Continued)

Function Number	Function Name and Telephone Display	Description	Programming Values
110	Touchtone Signal Duration and Pause Interval <i>P110 MF PATTERN</i> 111111	Used to assign the length of the touchtone (Dual Tone Multifrequency) signal and the pause time before the next signal is sent. This is used when DTMF is assigned to the trunk line and Dial Pulse (DP) is assigned for the switching signal.	0 = 400 ms(duration)/100 ms (pause) 1 = 100 ms(duration)/70 ms (pause)
111	NOT USED		
112	Line Reversal Assignment <i>P112 LINE REVERS</i> -----	Specifies whether a trunk is assigned with Line Reversal Signalling at the exchange.	1 = YES (Enabled) - = NO (Disabled) Note: ISDN lines must be set to YES.
113	No-ring Detection Time <i>P113 NO RING DET</i> 222222	Set this timer to be at least one second longer than the off-period in the ring cycle received from the exchange. This determines the amount of ring, which is produced by the system after the caller has hung up during ringing.	0 = 1 sec 1 = 2 sec 2 = 3 sec 3 = 4 sec 4 = 5 sec
119	Ring Tone Type <i>P119 RING CYCLE</i> 654321	Used to select either a low or high ringing tone.	1= Low - = High
124	External Speaker Tone Duration for Day Mode <i>P124 EXTSP DY</i> 555555	Used to assign the length of the tone sent to the external speaker to indicate an incoming call during day mode.	0 = 0 sec. 3 = 30 sec. 1 = 10 sec. 4 = 60 sec. 2 = 20 sec. 5 = No Tone
125	External Speaker Tone Duration for Night Mode <i>P125 EXTSP NT</i> 555555	Used to assign the length of the tone sent to the external speaker to indicate an incoming call during night mode.	
126	VRS Automatic Answer Assignment <i>P126 VRS ANSWER</i> -----	Specifies whether or not a trunk is to be automatically answered by the VRS answering facility.	1⇨6 = Auto Answer - = No Auto Answer
127	VRS Hold Message Assignment <i>P127 HOLD MSG</i> -----	Specify on which trunks the VRS hold message is to play when the trunk is placed on hold. MOH follows the hold message until the call is retrieved.	1⇨6 = Hold Message - = No Hold Message

Table 9-2: Trunk Programming Functions (Continued)

Function Number	Function Name and Telephone Display	Description	Programming Values
140	Direct Calling for Day Mode on Trunk Line 1 <i>P140 DIT LN1 DY</i>	Used to indicate an extension number (or voice mail number) that is used for direct calls (i.e., calls that are not routed through an attendant). This assignment applies to day mode.	Blank = No Assignment Extension Number 10⇒59
141	Direct Calling for Day Mode on Trunk Line 2 <i>P141 DIT LN2 DY</i>		
142	Direct Calling for Day Mode on Trunk Line 3 <i>P142 DIT LN3 DY</i>		
143	Direct Calling for Day Mode on Trunk Line 4 <i>P143 DIT LN4 DY</i>		
144	Direct Calling for Day Mode on Trunk Line 5 <i>P144 DIT LN5 DY</i>		
145	Direct Calling for Day Mode on Trunk Line 6 <i>P145 DIT LN6 DY</i>		
146	Direct Calling for Night Mode on Trunk Line 1 <i>P146 DIT LN1 NT</i>	Used to indicate an extension number (or external voice mail number) that is used for direct calls (i.e., calls that are not routed through an attendant). This assignment applies to night mode.	Blank = No Assignment Extension Number 10⇒59
147	Direct Calling for Night Mode on Trunk Line 2 <i>P147 DIT LN2 NT</i>		
148	Direct Calling for Night Mode on Trunk Line 3 <i>P148 DIT LN3 NT</i>		
149	Direct Calling for Night Mode on Trunk Line 4 <i>P149 DIT LN4 NT</i>		
150	Direct Calling for Night Mode on Trunk Line 5 <i>P150 DIT LN5 NT</i>		
151	Direct Calling for Night Mode on Trunk Line 6 <i>P151 DIT LN6 NT</i>		

Table 9-2: Trunk Programming Functions (Continued)

Function Number	Function Name and Telephone Display	Description	Programming Values
152	Direct Calling Answer Delay Time <i>P152 DIT DLY</i> 000000	Used to specify the duration of the delay of incoming direct calls. This applies to calls received on a line assigned for direct calling.	0 = 0 sec. 4 = 30 sec. 1 = 1.5 sec. 5 = 40 sec. 2 = 10 sec. 6 = 50 sec. 3 = 20 sec. 7 = 60 sec.
153	Direct Calling Delay for Night Mode <i>P153 DIT DLY NT</i> 654321	Used to indicate whether the answer delay for direct called that are received in night mode are delayed.	1⇒6 = Enabled – = Disabled
154	Call Forward External Assignment (Trunk Based) <i>P154 CFE ALLOW T</i> - - - - -	Specifies whether a trunk is allowed to be set as the outgoing trunk of a Call Forward External Assignment.	1⇒6 = CFE Allowed – = CFE Disabled
155	GDN to Trunk Assignment (Day Mode - ISDN only) <i>P155 GDN DAY</i> 03 = - -	Assigns a GDN to each ISDN trunk for Day mode operation.	Indial Mode = 2 digit ISDN Table NO (00⇒99) MSN Mode = 2 digit index Table No (01⇒16) Default = Not Assigned
156	GDN to Trunk Assignment (Night Mode - ISDN only) <i>P156 GDN NIGHT</i> 03 = - -	Assigns a GDN to each ISDN trunk for Night mode operation.	Indial: Indial mode setting uses the last 2 digits of an incoming number for matching. Therefore, valid data values for P155/156 in this mode are (00⇒99). MSN: MSN mode must have the ISDN interface number, excluding area code assigned to an index number in P065. The index number (01⇒16) is then used for matching incoming calls in P155/156.

Telephone Port Programming

Programming Note To change the default setting for a telephone port, dial the 2 digit number that corresponds to the telephone you want to change (01 to 6, as appropriate). For example, to change the setting for telephone Port 10, dial "1", "0". Depending on the function number, dialling the port number will either toggle its setting between two values or, where more than two values are available, will cause that setting to flash. When the setting flashes, you are required to enter a third digit, this being the new programming value (0 to 9, as appropriate). Port numbers are shown in descending order, with Port 01 on the right-hand side of the display.

Table 9-3: Telephone Port Programming

Function Number	Function Name and Telephone Display	Description	Programming Values
202	Off-Hook Ringing Tone <i>P202 OFFHK RING</i> 11111111111111	Used to indicate whether a ringing tone is sent when the user is engaged in a conversation. This tone signals the user that there is an incoming call (on a trunk line).	1 = Enabled – = Disabled
203	Trunk Line Barge-In <i>P203 CO BRG IN</i> -----	Used to indicate (for each telephone) if barge-in is allowed when the user is engaged in a call using a trunk line.	1 = Enabled – = Disabled
205	Hot Line/Prime Line Assignment <i>P205 HOT LINE</i> 01:_	Program up to 12 digits to be dialled when the station user goes off-hook.	Up to 12 digits (0–9, *, #). Default = Not Specified
206	Extension Number Assignment <i>P206 STATION NO</i> NO01 = 10	Used to assign an extension number to each telephone in the system.	Available Extension Numbers = 10⇒59 Default: Ports 01⇒16 = Ext 10⇒25 UCD Pilot 1 & 2 = Ext.40⇒41 VMS Ports 1 & 2 = Ext.50⇒51
Programming Note: To change the extension number for the displayed port, press the numbers on the dial pad that correspond to the extension number.			
207	Single Line Port Type <i>P207 SLT TYPE</i> --	Used to designate whether the single line port is connected to a single line telephone.	– = Not Connected 1 = Single Line Telephone
208	Single Line Dialling Type <i>P208 SLT TYPE</i> 11111111111111	Used to assign the dialling type for single line telephones. The options are rotary (Dial Pulse) or touchtone (Dual Tone Multifrequency).	– = Dial Pulse (Rotary) 1 = Dual Tone Multifrequency (Touchtone)
Programming Note: Even though you can assign all 10 ports as single line telephones, this is not recommended. If you are going to use a telephone to program the system, one telephone must be a multiline telephone.			

Table 9-3: Telephone Port Programming (Continued)

Function Number	Function Name and Telephone Display	Description	Programming Values
209	Outgoing Call Priority Mode <i>P209 CALL PREFER</i> -----	Used to select the line that is seized first when the user goes off-hook. The system can be programmed to either seize an internal or external line for multiline telephones and single line telephones.	1 = External Line – = Internal Line
210	Doorphone 1 Tone for Day Mode <i>P210 DPH1 CHM DY</i> 1111111111111111	Used to assign a specified telephone to produce a tone (chime) signal when the doorphone receives a call. This assignment applies to day mode for multiline and single line telephones.	1 = Tone – = No Tone
211	Doorphone 2 Tone for Day Mode <i>P211 DPH2 CHM DY</i> 1111111111111111		
213	Doorphone 1 Tone for Night Mode <i>P213 DPH1 CHM NT</i> -----11	Used to assign a specified telephone to produce a tone (chime) signal when the doorphone receives a call. This assignment applies to night mode for multiline and single line telephones.	1 = Tone (this is the default setting for telephones 1 and 2) – = No Tone (this is the default setting for telephone Ports 3⇨10)
214	Doorphone 2 Tone for Night Mode <i>P214 DPH2 CHM NT</i> -----11		
216	Handsfree Assignment <i>P216 HFU</i> 1111111111111111	Used to assign (for each multiline telephone) handsfree operation.	1 = Enabled – = Disabled
217	Internal All Call Paging Tone <i>P217 PAGE EXT</i> 1111111111111111	Used to enable or disable call paging tone for each multiline telephone. The page will still be displayed on each multiline telephone and can be answered by any multiline telephone in the system.	1 = Enabled – = Disabled
218	Headset Connection <i>P218 HEADSET</i> 1111111111111111	Used to indicate if a headset is connected an DTU-Type multiline telephone. When connected, LK16 becomes the headset key.	– = Not Connected 1 = Connected
219	Restricted Calling for External Calls <i>P219 RST/ALLW DY</i> -----	Used to restrict outgoing calls on a specific line. Restrictions can be set for multiline telephones and single line telephones.	– = Not Restricted 1 = Restricted

Table 9-3: Telephone Port Programming (Continued)

Function Number	Function Name and Telephone Display	Description	Programming Values
220	Restricted Dialling Table Selection <i>P220 REST TBL DY</i> 000000000000000000	Specifies which Restricted Dialling Table (1 or 2) is used for each telephone in the system (includes both multiline and single line telephones).	0 = Not Used 1 = Table 1 (Table assigned using function 020) 2 = Table 2 (Table assigned using function 021) 3 = Tables 1 & 2 (table assigned using function 020 and 021)
Programming Note:	<i>To change the defaults value for function 220 and 221, dial the 2 digit number. The number will blink, indicating your selection. Press the number that corresponds to the programming value (0, 1, 2).</i>		
221	Authorised Dialling Table Selection <i>P221 ALLW TBL DY</i> 000000000000000000	Specifies which Authorised Dialling Table (1 or 2) is used for each telephone in the system (includes both multiline and single line telephones).	0 = Not Used 1 = Table 1 (Table assigned using function 020) 2 = Table 2 (Table assigned using function 021) 3 = Tables 1 & 2 (table assigned using function 020 and 021)
222	Authorised Dialling for System Speed Dial Calls <i>P222 RST SPD DL</i> 1111111111111111	Used to assign specific system (common) speed dial memory locations (60⇒99), which follow Toll Restrictions when a port is set to Deny. System speed dial memory locations (20⇒59) always bypass Toll restrictions. When system speed dial 200 is set in P001–2, then a deny setting will invoke Toll restrictions for buffers (000⇒199) and an ‘allow entry’ will bypass.	1 = Denied (number cannot be dialled) – = Allowed (number can be dialled)
223	Call restriction for unmatched numbers <i>P223 NO MATCH DL</i> 1111111111111111	Assigns outgoing call operation when there is no match against dialled numbers in the Restriction/Authorisation table.	1 = Unmatched NO. Allowed – = Unmatched NO. Restricted
Programming Note:	<i>When setting P223 on a Version 2 system or later, the software allows access to Ports 15 and 16 for this programming parameter.</i>		
225	External Ring Assignment (Day) – Station Based <i>P225 EXT RG-ST DY</i> 5555555555555555	External ringing operates for incoming DID, DIT and CO Ring Transferred calls to telephones 1⇒16 (Day mode).	0 = 0 sec 4 = 60 sec 1 = 10 sec 5 = Doesn't sound 2 = 20 sec 3 = 30 sec

Table 9-3: Telephone Port Programming (Continued)





Function Number	Function Name and Telephone Display	Description	Programming Values
226	External Ring Assignment (Night) – Station Based <i>P226 EXT RG-ST NT</i> 5555555555555555	External ringing operates for incoming DID, DIT and CO Ring Transferred calls to telephones 1→16 (Night mode).	0 = 0 sec 4 = 60 sec 1 = 10 sec 5 = Doesn't sound 2 = 20 sec 3 = 30 sec
227	Telephone to Paging Zone A Assignment <i>P227 ZONE A</i> -----	Assigns terminals to Paging Zone A.	1 = Assigned - = Not Assigned
228	Telephone to Paging Zone B Assignment <i>P228 ZONE B</i> -----	Assigns terminals to Paging Zone B.	1 = Assigned - = Not Assigned
229	Call Forward External Assignment – Station Based <i>P229 CFE ALLOW S</i> -----	Specifies whether each station is allowed to set Call Forward External.	1 = CFE Allowed - = CFE Denied
231	Station Indial Ring Pattern Selection <i>P231 DID RNG PAT</i> 0000000000000000	Select a ring pattern for indial calls to each station port. A DID call will ring with this cadence.	0 = Pattern A 1 = Pattern B 2 = Pattern C 3 = Pattern D
		PATTERN: 0s1s2s3s4s5s6s A  B  C  D 	
232	Station Indial Ring Tone Selection <i>P232 DID RNG TON</i> 0000000000000000	Select ring tone for indial calls to each station port. A DID call to a station will ring with this tone.	0 = High Tone (1100/1400 Hz) 1 = Low Tone (520/660 Hz)
233	Manual Trunk to Trunk Transfer Selection <i>P233 TRNK TRNSFR</i> 1111111111111111	Specifies whether a station is allowed to perform a trunk to trunk transfer (ie. transfer one trunk call out another trunk to an external destination).	1 = Allowed - = Denied

Table 9-3: Telephone Port Programming (Continued)

Function Number	Function Name and Telephone Display	Description	Programming Values
235	VRS Message Set/Record/Verify/Cancel Assignment <i>P235 VRS MSG SET</i> ----- 11	Specifies which stations are allowed to Set/Cancel the VRS Answering facility or Record/Verify/Delete the various VRS messages.	1 = Allowed – = Denied Default: Ports 01⇒02 = Allowed Ports 03⇒14 = Denied Ports 15⇒20 = N/A
236	VRS Manual Answer Message Assignment <i>P236 VRS MAN ANS</i> ----- 11	Specify whether or not each station can activate the Manual Answer Message facility.	1 = Allowed (Ports 1&2 only) – = Denied
237	ACR Table Assignment <i>P237 ACR ASSIGN</i> 00000000000000	Assigns ACR operation to each station. When the specified station attempts to seize a trunk, ACR mode is automatically invoked.	0 = Not Assigned 1 = Use ACR Table 1 2 = Use ACR Table 2
238	ACR Bypass <i>P238 ACR BYPASS</i> -----	Allows specific stations to bypass ACR by pressing a Line Key or dialling a trunk access code (63x) to seize an idle trunk to make an outgoing call.	1 = Allow Bypass – = Deny Bypass
239	Restricted Calling for External Calls (Night Mode) <i>P239 RST/ALLW NT</i> -----	Used to restrict outgoing calls on a specific line. Restrictions can be set for Multiline and Single Line telephones.	– = Not Restricted 1 = Restricted
240	Restricted Dialling Table Selection (Night Mode) <i>P240 REST TBL NT</i> 0000000000000000	Specifies which Restricted Dialling Table (1 or 2) is used for each telephone in the system (includes both Multiline and Single Line telephones.)	0 = Not Used 1 = Table 1 (Table assigned using function 030) 2 = Table 2 (Table assigned using function 031) 3 = Tables 1&2 (Table assigned using functions 030 & 031)
241	Authorised Dialling Table Selection (Night Mode). <i>P241 ALLW TBL NT</i> 0000000000000000	Specifies which Authorised Dialling Table (1 or 2) is used for each telephone in the system (includes both Multiline and Single Line telephones).	0 = Not Used 1 = Table 1 (Table assigned using function 032) 2 = Table 2 (Table assigned using function 033) 3 = Tables 1&2 (Table assigned using functions 032 & 033)
242	Receiver Volume Level <i>P242 RECVE LEVEL</i> -----	Specify whether a manual adjustment in the handset receiver volume of a trunk call is held or reset to default when the call is ended and the telephone returned to idle.	1 = Retain Adjusted Level – = Return to Default Level

Table 9-3: Telephone Port Programming (Continued)

Function Number	Function Name and Telephone Display	Description	Programming Values
243	ISDN Supplementary Services <i>P243 SUP SERVICE</i> -----	Specify whether a station is allowed to activate the supplementary services provided over the ISDN network.	1 = Allowed – = Denied
244	Extension Caller ID (Day Mode) <i>P244 EXT CLI DAY</i> 01:–	Specify the Caller ID number to be sent from an extension when making an outgoing call over an ISDN service during day mode.	Default = Extensions 01⇒16 = Not Assigned Settings up to 13 digits 0⇒9 (including the area code, minus the leading zero).
245	Extension Caller ID (Night Mode) <i>P245 EXT CLI NGT</i> 01:–	Specify the Caller ID number to be sent from an extension when making an outgoing call over an ISDN service during night mode.	Default = Extensions 01⇒16 = Not Assigned Settings up to 13 digits 0⇒9 (including the area code, minus the leading zero).
246	Caller ID Restriction (CLIR) <i>P246 CLIR</i> -----	Specify whether each extension shall restrict Caller ID when making an outgoing call over an ISDN service.	1 = Present CLI – = Restrict CLI
247	Virtual Extension Assignment <i>P247 VE ASSIGN</i> 1111111111111111	Specify whether a user is allowed to assign on their extension a virtual extension (VE) key. A VE is an extension port which does not have a physical telephone connected to it.	1 = Allowed – = Denied
248	Line Key or Call Appearance Key Mode <i>P248 LK/CAP MODE</i> -----	Specifies whether each extension is to operate with Line Keys or Call Appearance Keys for handling trunk calls. When assigned to Call Appearance Key Mode, Line Keys 1 and 2 become Call Appearance Keys, while all other Line Keys become one-touch keys.	– : Line Key Mode 1 : Call Appearance Key Mode

Trunk Telephone Menu Programming

Programming Note To change the default setting for a telephone port, dial the 2 digit number that corresponds to the telephone you want to change (01 to 14, or 01 to 16, as appropriate). For example, to change the setting for telephone Port 10, dial “1”, “0”. Depending on the function number, dialling the port number will either toggle its setting between two values or, where more than two values are available, will cause that setting to flash. When the setting flashes, you are required to enter a third digit, this being the new programming value (0 to 9, as appropriate). Port numbers are shown in descending order, with Port 01 on the right-hand side of the display.

Table 9-4: Trunk Telephone Menu Programming

Function Number	Function Name and Telephone Display	Description	Programming Values
301	Delayed Ringing for Trunk Line 1 for Day Mode <i>P301 C01 RING DY</i> <i>000000000000000000</i>	Used to assign the duration of the delay between the time the call is received and the time the ringing tone is heard. This option allows you to delay ringing to another telephone. This assignment is for day mode.	0 = 0 sec. 3 = 30 sec. 1 = 8 sec. 4 = 60 sec. 2 = 16 sec. 5 = No Tone
302	Delayed Ringing for Trunk Line 2 for Day Mode <i>P302 C02 RING DY</i> <i>000000000000000000</i>		
303	Delayed Ringing for Trunk Line 3 for Day Mode <i>P303 C03 RING DY</i> <i>000000000000000000</i>		
304	Delayed Ringing for Trunk Line 4 for Day Mode <i>P304 C04 RING DY</i> <i>000000000000000000</i>		
305	Delayed Ringing for Trunk Line 5 for Day Mode <i>P305 C05 RING DY</i> <i>000000000000000000</i>		
306	Delayed Ringing for Trunk Line 6 for Day Mode <i>P306 C06 RING DY</i> <i>000000000000000000</i>		

Table 9-4: Trunk Telephone Menu Programming (Continued)

Function Number	Function Name and Telephone Display	Description	Programming Values
311	Delayed Ringing for Trunk Line 1 for Night Mode <i>P311 CO1 RING NT</i> 000000000000000000	Used to assign the duration of the delay between the time the call is received and the time the ringing tone is heard. This option allows you to delay ringing to another telephone. This assignment is for night mode.	0 = 0 sec. 3 = 30 sec. 1 = 8 sec. 4 = 60 sec. 2 = 16 sec. 5 = No Tone
312	Delayed Ringing for Trunk Line 2 for Night Mode <i>P312 CO2 RING NT</i> 000000000000000000		
313	Delayed Ringing for Trunk Line 3 for Night Mode <i>P313 CO3 RING NT</i> 000000000000000000		
314	Delayed Ringing for Trunk Line 4 for Night Mode <i>P314 CO4 RING NT</i> 000000000000000000		
315	Delayed Ringing for Trunk Line 5 for Night Mode <i>P315 CO5 RING NT</i> 000000000000000000		
316	Delayed Ringing for Trunk Line 6 for Night Mode <i>P316 CO6 RING NT</i> 000000000000000000		

Table 9-4: Trunk Telephone Menu Programming (Continued)



Function Number	Function Name and Telephone Display	Description	Programming Values
331	Automatic Line Selection for Trunk Line 1 <i>P331 CO1 ATL ORG</i> <i>11111111111111111111</i>	Used to designate which line keys are used for automatic line key selection. This is used to automatically seize a line by pressing  (DTB-Type telephones) or  , or going off-hook and dialling the appropriate outside line access code. This is designated for each telephone.	1 = Enabled – = Disabled
332	Automatic Line Selection for Trunk Line 2 <i>P332 CO2 ATL ORG</i> <i>11111111111111111111</i>		
333	Automatic Line Selection for Trunk Line 3 <i>P333 CO3 ATL ORG</i> <i>11111111111111111111</i>		
334	Automatic Line Selection for Trunk Line 4 <i>P334 CO4 ATL ORG</i> <i>11111111111111111111</i>		
335	Automatic Line Selection for Trunk Line 5 <i>P335 CO5 ATL ORG</i> <i>11111111111111111111</i>		
336	Automatic Line Selection for Trunk Line 6 <i>P336 CO6 ATL ORG</i> <i>11111111111111111111</i>		

Table 9-4: Trunk Telephone Menu Programming (Continued)

Function Number	Function Name and Telephone Display	Description	Programming Values
341	Automatic Answering using Trunk Line 1 <i>P341 CO1 ATL ANS</i> 11111111111111111111	Used to enable or disable the ability to answer an incoming call by going off-hook. If enabled, the user answers the call by going off-hook. If disabled, the user answers the call by going off-hook and pressing the line key where the call is ringing. Only multiline telephones can be assigned this option.	1 = Enabled – = Disabled
342	Automatic Answering using Trunk Line 2 <i>P342 CO2 ATL ANS</i> 11111111111111111111		
343	Automatic Answering using Trunk Line 3 <i>P343 CO3 ATL ANS</i> 11111111111111111111		
344	Automatic Answering using Trunk Line 4 <i>P344 CO4 ATL ANS</i> 11111111111111111111		
345	Automatic Answering using Trunk Line 5 <i>P345 CO5 ATL ANS</i> 11111111111111111111		
346	Automatic Answering using Trunk Line 6 <i>P346 CO6 ATL ANS</i> 11111111111111111111		
351	Restricting Outgoing Calls for Trunk Line 1 <i>P351 CO1 RST OUT</i> 11111111111111111111	Used to enable or disable (for each telephone) the ability to make outgoing calls when 105 – Trunk Line Function is set to “Outgoing/Incoming Calls.” This option can be used with multiline and single line telephones.	1 = Outgoing Calls Enabled – = Outgoing Calls Disabled
352	Restricting Outgoing Calls for Trunk Line 2 <i>P352 CO2 RST OUT</i> 11111111111111111111		
353	Restricting Outgoing Calls for Trunk Line 3 <i>P353 CO3 RST OUT</i> 11111111111111111111		
354	Restricting Outgoing Calls for Trunk Line 4 <i>P354 CO4 RST OUT</i> 11111111111111111111		

Table 9-4: Trunk Telephone Menu Programming (Continued)





Function Number	Function Name and Telephone Display	Description	Programming Values
355	Restricting Outgoing Calls for Trunk Line 5 <i>P355 CO5 RST OUT</i> 1111111111111111		
356	Restricting Outgoing Calls for Trunk Line 6 <i>P356 CO6 RST OUT</i> 1111111111111111		
361	Ringing Cycle for Trunk Line 1 <i>P361 CO1 RNG SND</i> 1111111111111111	Select a ring pattern for Trunk calls to each MLT port.	0 = Pattern A 1 = Pattern B 2 = Pattern C 3 = Pattern D
362	Ringing Cycle for Trunk Line 2 <i>P362 CO2 RNG SND</i> 1111111111111111		
363	Ringing Cycle for Trunk Line 3 <i>P363 CO3 RNG SND</i> 1111111111111111	<p>PATTERN:</p> <p>0s1s2s3s4s5s6s</p> <p>A </p> <p>B </p> <p>C </p> <p>D </p>	
364	Ringing Cycle for Trunk Line 4 <i>P364 CO4 RNG SND</i> 1111111111111111		
365	Ringing Cycle for Trunk Line 5 <i>P365 CO5 RNG SND</i> 1111111111111111		
366	Ringing Cycle for Trunk Line 6 <i>P366 CO6 RNG SND</i> 1111111111111111		
371	NOT USED		
372	NOT USED		
373	NOT USED		

Table 9-4: Trunk Telephone Menu Programming (Continued)

Function Number	Function Name and Telephone Display	Description	Programming Values
374	NOT USED		
375	NOT USED		
376	NOT USED		

Tenant Programming

Programming Note To change the default settings, dial the 1 digit trunk Port numbers 1⇒6 (function 401⇒402) or 2 digit telephone Port numbers 01⇒16 (function 403) to toggle its setting between 'assigned' and 'not assigned'. For example, to change the setting for telephone Port 10, dial "1" and "0". Port numbers are shown in descending order with Port 01 on the right-hand side of the display.

Table 9-5: Tenant Programming

Function Number	Function Name and Telephone Display	Description	Programming Values
401	Trunk Line Assignment for Tenant 1 <i>P401 TENANT1 CO</i> 654321	Used to specify the trunk lines assigned as part of the tenant.	1 = Assigned to Tenant 1 – = Not Assigned to Tenant 1
402	Trunk Line Assignment for Tenant 2 <i>P402 TENANT2 CO</i> -----		1 = Assigned to Tenant 2 – = Not Assigned to Tenant 2
403	Tenant-to-Telephone Assignment <i>P403 TENANT</i> 11111111111111111111	Used to assign each telephone to a tenant. Both multiline and single line telephones can be assigned to a tenant.	1 = Assigned to Tenant 1 – = Assigned to Tenant 2

System Mode Programming

Programming To change the default setting for a telephone port, dial the 1 digit number which corresponds to the new programming value. For example, to change the setting for function number 503 to 90 ms, dial "1".

Table 9-6: System Mode Programming

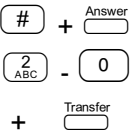

Function Number	Function Name and Telephone Display	Description	Programming Values
501	Doorphone Call Timer <i>P501 DPH RING TM</i> 0	Used to indicate how long "Doorphone X" appears on the telephone display when a call is received from a doorphone. Note: X = Doorphone Number (1 & 2).	0 = 15 sec. 1 = 30 sec.
502	Single Line Telephone Bounce Time <i>P502 BOUNCE TIME</i> 1	Used to indicate the time that passes before a valid hookflash is detected from a single line telephone.	0 = 0 ms. 2 = 600 ms. 1 = 300 ms. 3 = 900 ms.
503	Single Line Telephone Hookflash Start Time <i>P503 SLT FLSH ST</i> 0	Start time indicates the minimum time that passes before the system accepts a hookflash signal. Start time is used in conjunction with 504 (Single Line Telephone Hookflash End Time).	0 = 100 ms. 5 = 450 ms. 1 = 150 ms. 6 = 550 ms. 2 = 200 ms. 7 = 650 sec. 3 = 300 ms. 8 = 750 sec. 4 = 350 ms. 9 = 850 sec.
504	Single Line Telephone Hookflash End Time <i>P504 SLT FLSH ED</i> 1	End time indicates the maximum time that passes before the system recognises the flash as a valid hookflash. If the flash is longer than the time set, the system considers the flash as a disconnect signal. To determine the duration of the hookflash signal, the system computes using the following formula: SLT Hookflash Start Time + SLT Hookflash End Time = SLT Duration. End time is used in conjunction with 503 (Single Line Telephone Hookflash Start Time).	0 = 0 ms. 5 = 700 ms. 1 = 100 ms. 6 = 900 ms. 2 = 200 ms. 7 = 1.1 sec. 3 = 400 ms. 8 = 1.3 sec. 4 = 500 ms. 9 = 1.5 sec.

Table 9-6: System Mode Programming (Continued)

Function Number	Function Name and Telephone Display	Description	Programming Values
505	Trunk Line Prepause Duration <i>P505 PRE PAUSE</i> 2	Used to specify the time (prepause) before the system sends dial pulse (rotary) or dual-tone multifrequency (touchtone) signals to the local telephone company.	0 = 0 sec 5 = 5 sec 1 = 1 sec 6 = 6 sec 2 = 2 sec 7 = 7 sec 3 = 3 sec 8 = 8 sec 4 = 4 sec 9 = 9 sec
<p>Programming Note: To access 501⇒505 you must press # to and enter the function number using the dialpad. You cannot access these functions by scrolling.</p>			
	Clear Automatic Speed Dial Numbers <i>AUTO DIAL CLR?</i>	Used to clear all the one-touch numbers for an individual telephone.	N/A

Maintenance Modes

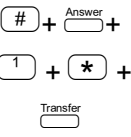
Table 9-7: Maintenance Modes

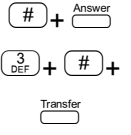
Function	Function Name and Telephones Display	Description	Programming Values
	Check ROM Version <i>1:MAIN ROM = X.X</i>	Used to check the ROM versions for the central processing unit, voice mail, PC programming and SMDR units.	1 = Main ROM (Main CPU) 2 = Optional Sub-CPU 3 = Digital Voice Mail 4 = MIF Unit
	Clear Speed Dial Numbers System-Wide <i>CLR</i>	Used to delete all of the speed dial numbers for the entire system.	N/A
<p>Programming Note: To complete this operation you must press  .</p>			
	Clear Speed Dial Numbers for Individual Telephones <i>TEL SPED CLR?</i>	Used to delete all of the speed dial numbers for an individual telephone.	N/A