SL1100

Hardware Manual

Copyright

NEC shall not be liable for any direct, indirect, consequential or incidental damages about the use of this equipment, manual or any related materials.

NEC Corporation reserves the right to change the specifications, functions, or features at any time without notice.

NEC Corporation has prepared this document for use by its employees and customers. The information contained herein is the property of NEC Corporation and shall not be reproduced without prior written approval of NEC Corporation.

Copyright 2011 - 2012

NEC Corporation

Printed in Japan

TABLE OF CONTENTS

Chapter1 Introduction 1-1

SECTION 1 GENERAL INFORMATION	1-1
SECTION 2 EQUIPMENT LIST	1-2
2.1 KSUs and Optional Unit	1-3
2.1.1 IP4[]-1228M-B KSU	1-3
2.1.2 IP4WW-Battery Box	1-3
2.2 Trunk/Extension/ISDN Expansion Interface Cards	1-3
2.2.1 IP4WW-080E-B1	1-3
2.2.2 IP4[]-008E-B1	1-4
2.2.3 IP4WW-000E-B1	1-4
2.2.4 IP4WW-4COIDB-B1	1-4
2.2.5 IP4WW-2BRIDB-C1	1-4
2.2.6 IP4WW-1PRIU-C1	1-4
2.3 Optional Interface Cards	1-5
2.3.1 IP4[]-MEMDB-C1	1-5
2.3.2 IP4WW-VOIPDB-C1	1-5
2.3.3 PZ-VM21	1-5
2.3.4 IP4WW-CFVMS-C1	1-5
2.4 Multiline Telephones and Optional Equipment	1-6
2.4.1 IP4WW-12TXH-B TEL	1-6
2.4.2 IP4WW-24TXH-B TEL	1-6
2.4.3 IP4[]-24TIXH-C TEL	1-6
2.4.4 IP4WW-60D DSS-B	1-7
2.4.5 DP-D-1D	1-7
SECTION 3 SYSTEM CAPACITY	1-8
3.1 System Capacity	1-8
3.2 KSU Capacity	1-9
3.2.1 Expandability of Trunk and Extension (without PRI)	1-9
3.2.2 Expandability of Trunk and Extension (with PRI)	1-10

Chapter2 Installation 2-1

SECTION 1 INSTALLING THE MAIN KSU	2-1
1.1 Before Installing the KSU	2-1
1.1.1 General Precautions	2-1
1.1.2 Preparations	2-1
1.1.3 Site Requirements	2-1
1.1.4 Environmental Requirements	2-1
1.1.5 Unpacking	2-2
1.2 Installing the Main KSU (1228M-B KSU)	2-2
1.3 Wall-Mounting the KSU	2-3
1.3.1 KSU Dimensions	2-3
1.3.2 Wall Installation of KSU	2-3
1.3.3 Mounting Procedure of KSU	2-4
1.4 Grounding and AC Cabling	2-6
1.4.1 Grounding the KSU	2-6
1.4.2 AC Power Requirement	2-7

TABLE OF CONTENTS

1.4.3	AC Power Cord	2-7
1.5	Trunk/Extension Cabling	2-8
1.5.1	General	2-8
1.5.2	Precautions for Cabling	2-8
1.5.3	Trunk Cabling	2-8
1.5.4	Extension Cabling	2-9
1.5.5	Cable Routing and Clamping	2-11
SECTION 2 INSTALLING THE EXTERNAL BACKUP BATTERY		2-12
2.1	General	2-12
2.2	Unpacking	2-12
2.3	Battery Box Dimensions	2-13
2.4	Battery Specifications	2-13
2.5	Battery Installation	2-13
2.6	Mounting the IP4WW-Battery Box	2-19
2.6.1	Floor-Mounting the IP4WW-Battery Box	2-19
2.6.2	Wall-Mounting the IP4WW-Battery Box	2-21
2.6.3	Mounting One KSU on the Battery Box	2-25
2.7	IP4WW-Battery Box to KSU Connection	2-28
2.8	IP4WW-Battery Box Fuse Replacement	2-29
SECTION 3 INSTALLING THE EXPANSION INTERFACE CARDS		2-33
3.1	General	2-33
3.2	Unpacking	2-33
3.3	Mounting the Expansion Interface Card	2-34
3.3.1	Mounting the 080E-B1/008E-B1/000E-B1 /1PRIU-C1 PCBs	2-34
3.3.2	Mounting the 4COIDB PCB	2-37
3.3.3	Mounting the 2BRIDB PCB	2-39
3.4	Cabling and Setting the Expansion Interface Card	2-42
3.4.1	Cabling IP4WW-080E-B1	2-42
3.4.2	Cabling IP4[]-008E-B1	2-43
3.4.3	Cabling IP4WW-000E-B1	2-44
3.4.4	Cabling and Setting IP4WW-4COIDB-B1	2-44
3.4.5	Cabling and Setting IP4WW-2BRIDB-C1	2-45
3.4.6	Cabling and Setting IP4WW-1PRIU-C1	2-46
3.5	Power Failure Transfer (4COIDB-B1 only)	2-49
3.5.1	General	2-49
SECTION 4 INSTALLING THE OPTIONAL INTERFACE CARDS		2-50
4.1	Installing the Expansion Memory Card (MEMDB-C1)	2-50
4.1.1	General	2-50
4.1.2	Unpacking	2-50
4.1.3	Installing the MEMDB PCB	2-50
4.2	VoIP Card (VOIPDB-C1)	2-53
4.2.1	General	2-53
4.2.2	Unpacking	2-53
4.2.3	Installing the VOIPDB-C1 PCB	2-53
4.2.4	LED Indication	2-57
4.3	VRS/Voice Mail Card (PZ-VM21)	2-58
4.3.1	General	2-58

TABLE OF CONTENTS

4.3.2	Unpacking	2-58
4.3.3	Installing the PZ-VM21 PCB	2-58
4.4	Installing the CF Card (CFVMS)	2-61

SECTION 5 INSTALLING THE MULTILINE TELEPHONES AND OPTIONAL TERMINALS 2-63

5.1	Installing the Multiline Telephones	2-63
5.1.1	Location of Controls	2-63
5.1.2	Multiline Telephone Legs Adjustment	2-64
5.1.3	Wall-Mounting the Multiline Telephone	2-66
5.2	Install the IP Multiline Telephone (IP4WW-24TIXH-C1 TEL)	2-68
5.2.1	System Connection	2-68
5.2.2	Installing the IP Multiline Telephone	2-69
5.2.3	Applying Power to the IP Multiline Telephone	2-69
5.3	Installing the DSS Console	2-70
5.3.1	DSS Console Leg Adjustment	2-70
5.3.2	Wall-Mounting the DSS Console	2-71
5.4	Installing the Headset	2-72
5.5	Installing the Doorphone Box	2-73
5.5.1	Wall-Mounting the Doorphone	2-73
5.5.2	Connecting the Doorphone	2-75
5.5.3	Doorphone Interface Specifications	2-75
5.6	Installing the Door Unlock Devices	2-75
5.7	Installing the External Paging Speaker/External MOH/BGM Sources	2-76
5.7.1	Connecting the Audio Equipment	2-76
5.7.2	External Paging Output Specifications	2-77
5.7.3	BGM/External MOH Source Input Specifications	2-77
5.8	SMDR (Station Message Detail Recording)	2-78
5.8.1	General	2-78

Chapter3 System Start Up 3-1

SECTION 1 SYSTEM START UP 3-1

1.1	Before Starting Up the System	3-1
1.2	Starting Up the System	3-1
1.2.1	Perform a Cold Start	3-1
1.2.2	Perform a Hot Start	3-3

SECTION 2 PROGRAMMING MODE 3-4

2.1	Entering the Programming Mode	3-4
2.2	Exiting the Programming Mode	3-4
2.3	Saving (Backup) the Customer Data	3-5
2.4	Loading the Customer Data	3-5

SECTION 3 SYSTEM SHUT DOWN 3-7

3.1	Powering Off the System	3-7
3.2	Resetting the System	3-7

TABLE OF CONTENTS

Chapter4 Maintenance 4-1

SECTION 1 FUSE REPLACEMENT	4-1
1.1 Replacing the Fuse	4-1
SECTION 2 LITHIUM BATTERY REPLACEMENT	4-3
2.1 General	4-3
2.2 Lithium Battery Specification	4-3
2.3 Replacing the Lithium Battery	4-3
SECTION 3 MAIN SOFTWARE UPGRADING	4-8
3.1 General	4-8
3.2 Before Upgrading the Main Software	4-8
3.3 Main Software Version Confirmation	4-8
3.4 Upgrading the Main Software	4-9
SECTION 4 LED INDICATIONS	4-12

Chapter5 Specifications 5-1

SECTION 1 SYSTEM CAPACITY	5-1
SECTION 2 SYSTEM SPECIFICATIONS	5-2
2.1 General Precautions	5-2
2.2 Environmental Requirements	5-2
2.3 Operating Conditions	5-2
2.4 Site Requirements	5-2
2.5 AC Power Requirement	5-2
2.6 Electrical Specifications <Power Supply> (KSU)	5-3
2.7 CPU	5-3
2.8 Traffic Capacity	5-3
2.9 IP Terminal Power Chart	5-3
2.10 IEEE802.af Class Specification	5-4
2.11 Mechanical Specifications	5-4
2.12 Optional Unit Mechanical Specifications	5-4
2.13 Doorphone Interface Specifications	5-4
2.14 General Purpose/Door Unlock Relay Specifications	5-5
2.15 External Paging Output Specifications	5-5
2.16 BGM/ExMOH Source Input Specifications	5-5
2.17 External Sensor Device Interface Specifications	5-5
2.18 CPU Card LAN Port Specifications	5-5
2.19 Cabling Requirements	5-5
2.20 Cable Requirements	5-6

LIST OF TABLES

Table 1-1 Memory Capacity of MEMDB-C1	1-5
Table 1-2 System Capacity.....	1-8
Table 2-1 KSU Packing List.....	2-2
Table 2-2 Items on the CPU card	2-2
Table 2-3 Power Requirement.....	2-7
Table 2-4 RJ61 Cable Connector Pin-Outs (J101-J103).....	2-11
Table 2-5 IP4WW-Battery Box Packing List	2-12
Table 2-6 Battery Specifications	2-13
Table 2-7 Expansion Cards	2-33
Table 2-8 Expansion Card Packing List.....	2-33
Table 2-9 RJ-61 Digital Connector Pin-Outs (J101, J102).....	2-43
Table 2-10 RJ-61 Analogue Pin-Outs (J101, J102).....	2-44
Table 2-11 RJ-61 CO/PF Pin-Outs (J2, J3)	2-45
Table 2-12 RJ-61 BRI Pin-Outs (S-Bus, T-Bus).....	2-45
Table 2-13 Switch Setting of 2BRIDB-C1	2-45
Table 2-14 RJ-45 PRI Pin-Outs (S-Bus, T-Bus).....	2-47
Table 2-15 Switch Setting of 1PRIU-C1	2-47
Table 2-16 LED Indication	2-48
Table 2-17 MEMDB-C1 Packing List.....	2-50
Table 2-18 VOIPDB-C1 Packing List.....	2-53
Table 2-19 VOIPDB LED Indications.....	2-58
Table 2-20 Operation of VOIPDB LED Indications	2-58
Table 2-21 PZ-VM21 Packing List.....	2-58
Table 2-22 Multiline Telephone Functions (12TXH/24TXH/24TIXH (IP)).....	2-64
Table 2-23 Doorphone Interface Specifications.....	2-75
Table 2-24 RJ-61 General Purpose/Door Unlock Relay Control Connector (J7)	2-76
Table 2-25 General Purpose/Door Unlock Relay Specifications	2-76
Table 2-26 External Paging Output Specifications	2-77
Table 2-27 BGM/External MOH Source Input Specifications	2-77
Table 3-1 Start Up Method.....	3-1
Table 4-1 Status LEDs.....	4-11
Table 4-2 CPU LED Indications.....	4-12
Table 5-1 System Capacity.....	5-1
Table 5-2 Operating Conditions.....	5-2
Table 5-3 Power Requirement.....	5-2
Table 5-4 Electrical Specifications of KSU.....	5-3
Table 5-5 IP Terminal Power Chart.....	5-3
Table 5-6 IEEE802.af Class Specification	5-4
Table 5-7 Mechanical Specifications	5-4
Table 5-8 Optional Unit Mechanical Specifications.....	5-4
Table 5-9 Doorphone Interface Specifications.....	5-4
Table 5-10 General Purpose/Door Unlock Relay Specifications	5-5
Table 5-11 External Paging Output Specifications.....	5-5
Table 5-12 BGM/External MOH Source Input Specifications	5-5
Table 5-13 External Sensor Device Interface Specifications	5-5
Table 5-14 CPU Card LAN Port Specifications.....	5-5
Table 5-15 Cable Requirements.....	5-6

LIST OF FIGURES

Figure 1-1 System Configuration.....	1-1
Figure 1-2 System Image.....	1-9
Figure 1-3 Maximum KSU Capacity - Expandability of Trunk and Extension (without PRI).....	1-9
Figure 1-4 Maximum KSU Capacity - Expandability of Trunk and Extension (with PRI)	1-10
Figure 2-1 CPU Card Location.....	2-2
Figure 2-2 Dimension of the Main KSU.....	2-3
Figure 2-3 Wall Mount of KSU.....	2-4
Figure 2-4 Wall-Mounting Template.....	2-4
Figure 2-5 Screw Positions	2-5
Figure 2-6 Sub-Cover Slide-out.....	2-5
Figure 2-7 Removing the Sub-Cover.....	2-5
Figure 2-8 Sub-Cover Open Position	2-6
Figure 2-9 Mounting the KSU.....	2-6
Figure 2-10 ETH Lug.....	2-7
Figure 2-11 AC Power Cord	2-8
Figure 2-12 Digital Extension Cabling.....	2-9
Figure 2-13 Analogue Extension Cabling.....	2-10
Figure 2-14 Cabling.....	2-11
Figure 2-15 Sub-Cover.....	2-11
Figure 2-16 Dimension of the IP4WW-Battery Box	2-13
Figure 2-17 Removing the Front Cover.....	2-14
Figure 2-18 Disconnect Battery Connection Cable	2-14
Figure 2-19 Batt Stopper	2-15
Figure 2-20 Pulling out the Battery Tray.....	2-15
Figure 2-21 Remove the Battery Tray Bracket.....	2-16
Figure 2-22 Battery Installation	2-16
Figure 2-23 Connecting the Battery Cables	2-17
Figure 2-24 Installation of Battery Tray Cover.....	2-17
Figure 2-25 Inserting the Battery Tray.....	2-18
Figure 2-26 Secure Batt Stopper Bracket.....	2-18
Figure 2-27 Connecting the Battery Connection Cable.....	2-19
Figure 2-28 Installation of Front Cover.....	2-19
Figure 2-29 Bases and Support of the Battery Box.....	2-20
Figure 2-30 Floor-Mount Spacing Guide	2-20
Figure 2-31 Mounting the Battery Box.....	2-21
Figure 2-32 Securing the Battery Box	2-21
Figure 2-33 Assemble Battery Box Base.....	2-22
Figure 2-34 Wall-Mount Spacing Guide.....	2-23
Figure 2-35 Removing the Front Cover.....	2-24
Figure 2-36 Mounting the Battery Box.....	2-24
Figure 2-37 Securing the Battery Box	2-25
Figure 2-38 Removing the Front Cover.....	2-25
Figure 2-39 Removing the L-Bracket	2-26
Figure 2-40 Securing the L-Bracket and WM Hook.....	2-27
Figure 2-41 Attaching the KSU.....	2-27
Figure 2-42 KSU Mounting on Battery Box	2-28
Figure 2-43 Sub-Cover Open and Hold.....	2-28
Figure 2-44 Connecting Battery Cable.....	2-29
Figure 2-45 Removing the Front Cover.....	2-30
Figure 2-46 Disconnecting the Battery Connection Cable	2-30
Figure 2-47 Loosen the Fuse Unit Screw.....	2-30

LIST OF FIGURES

Figure 2-48 Replacing the Fuse	2-31
Figure 2-49 Install the Fuse Unit	2-31
Figure 2-50 Securing the Fuse Unit	2-31
Figure 2-51 Connect Battery Connection Cable.....	2-32
Figure 2-52 Installation of the Front Cover	2-32
Figure 2-53 Removing the Sub-Cover.....	2-34
Figure 2-54 Removing the Main-Cover	2-34
Figure 2-55 Mounting the 1st Expansion Interface Card.....	2-35
Figure 2-56 Mounting the 2nd Expansion Interface Card.....	2-36
Figure 2-57 Mounting Two Expansion Interface Cards	2-36
Figure 2-58 Plastic Knockouts.....	2-37
Figure 2-59 Replacing the Main-Cover	2-37
Figure 2-60 Plastic Knockouts on 084M-B1/080E-B1/008E-B1/000E-B1	2-38
Figure 2-61 Installing the 4COIDB-B1	2-38
Figure 2-62 Mounting the 4COIDB-B1 into the KSU	2-39
Figure 2-63 Replacing the Main-Cover	2-39
Figure 2-64 Plastic Knockouts on 084M-B1/080E-B1/008E-B1/000E-B1	2-40
Figure 2-65 Installing the 2BRIDB-C1	2-40
Figure 2-66 Mounting the 2BRIDB-C1 into the KSU	2-41
Figure 2-67 Replacing the Main-Cover	2-41
Figure 2-68 Connectors of 080E-B1.....	2-42
Figure 2-69 Connectors of 008E-B1.....	2-43
Figure 2-70 Connectors of 4COIDB-B1.....	2-44
Figure 2-71 Connectors of 2BRIDB-C1	2-45
Figure 2-72 Switches Location of 2BRIDB-C1	2-46
Figure 2-73 Connector of 1PRIU-C1	2-47
Figure 2-74 Switches and LEDs Location of 1PRIU-C1	2-48
Figure 2-75 Removing the Sub-Cover.....	2-50
Figure 2-76 Removing the Main-Cover	2-51
Figure 2-77 Removing the CPU Card	2-51
Figure 2-78 Installing the MEMDB PCB	2-52
Figure 2-79 Installing the CPU Card	2-52
Figure 2-80 Replacing the Main-Cover	2-53
Figure 2-81 Removing the Sub-Cover.....	2-54
Figure 2-82 Removing the Main-Cover	2-54
Figure 2-83 Removing the CPU Card	2-55
Figure 2-84 Installing the VOIPDB-C1 PCB	2-55
Figure 2-85 Installing the CPU Card	2-56
Figure 2-86 Removing the Plastic Knockout and Replacing the Main-Cover.....	2-56
Figure 2-87 Connecting a LAN Cable	2-57
Figure 2-88 Location of LEDs.....	2-57
Figure 2-89 Removing the Sub-Cover.....	2-59
Figure 2-90 Removing the Main-Cover	2-59
Figure 2-91 Removing the CPU Card	2-60
Figure 2-92 Installing the PZ-VM21 PCB	2-60
Figure 2-93 Installing the CPU Card	2-61
Figure 2-94 Replacing the Main-Cover	2-61
Figure 2-95 Installing the CF Card	2-62
Figure 2-96 Multiline Telephone (12TXH/24TXH/24TIXH (IP)).....	2-63
Figure 2-97 Leg Setting for Low Position	2-64
Figure 2-98 Cabling of Multiline Telephone	2-65
Figure 2-99 Setting for High Position	2-65

LIST OF FIGURES

Figure 2-100 Leg Setting for High Position	2-66
Figure 2-101 Cabling for Wall-Mount.....	2-66
Figure 2-102 Wall-Mount Unit - 24TIXH-C	2-67
Figure 2-103 Hook-Switch Hanger	2-67
Figure 2-104 Wall-Mount Screw Guide	2-68
Figure 2-105 Mounting the Multiline Telephone	2-68
Figure 2-106 IP Multiline Telephone Connection.....	2-69
Figure 2-107 IP Multiline Telephone Connectors.....	2-69
Figure 2-108 Low Position Setting	2-70
Figure 2-109 Cabling of DSS	2-70
Figure 2-110 Leg Stopper of DSS Console	2-71
Figure 2-111 High Position Setting	2-71
Figure 2-112 Cabling for Wall-Mount.....	2-72
Figure 2-113 Wall-Mount Screw Guide.....	2-72
Figure 2-114 Mounting the DSS	2-72
Figure 2-115 Headset Socket (2-wire Multiline Telephone).....	2-73
Figure 2-116 Headset Socket (IP Multiline Telephone)	2-73
Figure 2-117 Doorphone Box and Bracket	2-74
Figure 2-118 Doorphone	2-74
Figure 2-119 Connecting the Doorphone	2-75
Figure 2-120 Connecting the Door Unlock Device	2-76
Figure 2-121 Connecting Audio Equipment.....	2-77
Figure 2-122 Connecting a PC for SMDR	2-78
Figure 3-1 Lithium Battery Protection Sheet	3-1
Figure 3-2 Power Switch Location.....	3-2
Figure 3-3 Load Button (S1) Location	3-2
Figure 3-4 Status LED (D5) and RUN LED Location.....	3-3
Figure 3-5 Display Indication (Idle).....	3-3
Figure 3-6 Entering Programming Mode Display 1	3-4
Figure 3-7 Entering Programming Mode Display 2	3-4
Figure 3-8 Exiting the Programming Mode Display 1	3-4
Figure 3-9 Exiting Programming Mode Display 2	3-4
Figure 3-10 Inserting the CF card	3-5
Figure 3-11 PRG90-03 Display	3-5
Figure 3-12 PRG90-04 Display	3-5
Figure 3-13 Inserting the CF card	3-6
Figure 3-14 PRG90-04 Display	3-6
Figure 3-15 Next PRG Display	3-6
Figure 3-16 Power Switch Location.....	3-7
Figure 4-1 Removing the Sub-Cover.....	4-1
Figure 4-2 Removing the Main-Cover	4-1
Figure 4-3 Exchanging the Fuse	4-2
Figure 4-4 Replacing the Main-Cover	4-2
Figure 4-5 Warning of Low Battery.....	4-3
Figure 4-6 Removing the Sub-Cover.....	4-4
Figure 4-7 Disconnecting the AC Power Cord.....	4-4
Figure 4-8 Removing the Main-Cover	4-5
Figure 4-9 Removing the CPU Card	4-5
Figure 4-10 Location of Lithium Battery Socket	4-6
Figure 4-11 Removing the Lithium Battery	4-6
Figure 4-12 Inserting the Lithium Battery	4-6
Figure 4-13 Installing the CPU Card	4-7

LIST OF FIGURES

Figure 4-14 Display of Multiline Telephone	4-8
Figure 4-15 Removing the Sub-Cover.....	4-9
Figure 4-16 Removing the Main-Cover	4-10
Figure 4-17 Inserting the CF card	4-10
Figure 4-18 LOAD Button (S1) Location	4-10
Figure 4-19 Removing the CF card	4-11

Regulatory

BATTERY DISPOSAL

The SL1100 system includes the batteries listed below. When disposing of these batteries, KSU, and/or Unit, you must comply with applicable regulations relating to your location regarding proper disposal procedures.

Unit Name	Type of Battery	Quantity	Note
IP4[]-CPU-B1	Lithium	1	
External Battery (IP4WW-Battery Box)	Sealed Lead	2 per IP4WW-Battery Box	

The SL1100 IP4[]-CPU-B1 provides memory backup for approximately three years. The Lithium battery should be replaced every two years.

IMPORTANT SAFEGUARDS FOR BATTERY DISPOSAL

DO NOT PLACE USED BATTERIES IN YOUR REGULAR WASTE! THE PRODUCT YOU PURCHASED CONTAINS LITHIUM, SEALED LEAD BATTERIES. LITHIUM, SEALED LEAD BATTERIES MUST BE COLLECTED, RECYCLED, OR DISPOSED OF IN AN ENVIRONMENTALLY SOUND MANNER.

The incineration, landfilling or mixing of sealed lead batteries with the municipal solid waste stream is **PROHIBITED BY LAW** in most areas. Contact your local solid waste management officials for other information regarding the environmentally sound collection, recycling, and disposal of the battery.

Sealed lead batteries must be returned to an approved sealed lead battery recycler. This may be where the batteries were originally sold or a local seller of automotive batteries. Contact your local waste management officials for other information regarding the environmentally sound collection, recycling and disposal of the battery contained in this product.

The packaging for the SL1100 system contains the following labels regarding proper disposal.

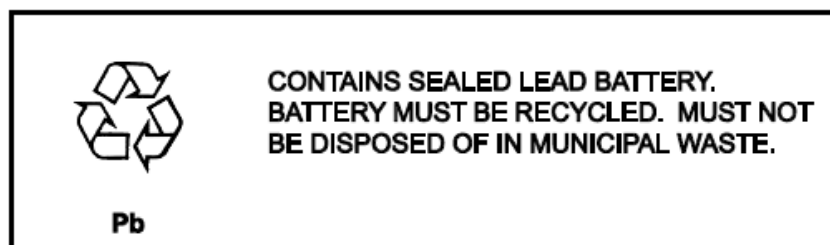

BATTERY INFORMATION

Defective or exhausted batteries should never be disposed of as municipal waste. Return old batteries to the battery supplier, a licensed battery dealer or a designated collection facility. Do not incinerate batteries. This product uses Lithium batteries. Do not use any other type.

For an overview of the location of batteries used in these systems, the battery replacement or removal instructions, please refer to the SL1100 System Hardware Manual.

AUSTRALIAN REGULATORY INFORMATION

ELECTROMAGNETIC INTERFERENCE (EMI)

This is a Class A product. In a domestic environment this product may cause radio interference in which case the user may be required to take adequate measures.

INCIDENCE OF HARM

If the System is malfunctioning, it may also be causing harm to the telephone network. The Telephone system should be disconnected until the source of the problem can be determined and until repair has been made. If this is not done, the Network Provider may temporarily disconnect the service.

HEARING AID COMPATIBILITY

The NEC Multiline Terminals that are provided for this system are hearing aid compatible. The manufacturer of Single Line Telephones for use with the system must provide notice of hearing aid compatibility to comply with ACA Technical Standards.

SERVICE REQUIREMENTS

This equipment must only be installed and maintained by service personnel. In the event of equipment malfunction, all repairs must be performed by an authorised dealer of NEC. It is the responsibility of users requiring service to report the need for service to one of NEC authorised agents.

COMPLIANCE INFORMATION

This equipment has been tested to comply with all relevant Australia and New Zealand regulatory requirements.

Warning: Small metal objects such as staples and pins may be caught and held in the earpiece and that the user should be aware and careful to prevent any accident from such an event.

The SL1100 system must be permanently connected to protective earth.

UL REGULATORY INFORMATION

This equipment has been listed by Underwriters Laboratories and complies with all applicable requirements of the standard for telephone equipment UL 1459.

VOICE ANNOUNCEMENT/MONITORING

The use of monitoring, recording or listening devices to eavesdrop, monitor, retrieve or record telephone conversations or other sounds activities, whether or not contemporaneous with its transmission may be illegal in certain circumstances under federal or state laws. Legal advice should be sought prior to implementing any practice that monitors or records any telephone conversation. Some federal and state laws require some form of notification to all parties to the telephone conversation, such as using a beep tone or other notification methods, or require the consent of all parties to the telephone conversation, prior to monitoring or recording a telephone conversation. Some of these laws incorporate strict penalties.

MUSIC ON HOLD

In accordance with Copyright Law, a license may be required from The Australian Performing Right Association Limited (APRA), or other similar organization, when radio or TV broadcasts are transmitted through the Music On Hold feature of this telecommunication system. NEC hereby disclaims any liability arising out of the failure to obtain such a license.

POWER FAILURE

The NEC SL1100 system is operated on 230VAC Mains power. The System and Terminals will not operate when the mains power fails unless Battery Back-up or a UPS is connected. If emergency telephone use is required a Battery back-up or UPS needs to be connected.

Introduction

SECTION 1 GENERAL INFORMATION

The SL1100 system is designed to support small businesses with simple installation and easy operation. The small compact KSU comes with an installed CPU and eight digital and four analogue extension ports and has two stackable slots for further expansion. The SL1100 provides a maximum of 12 analogue trunks and 24 Multiline terminals, and also equipped to support Digital Network (BRI/PRI) and IP Trunks (SIP) or IP extensions.

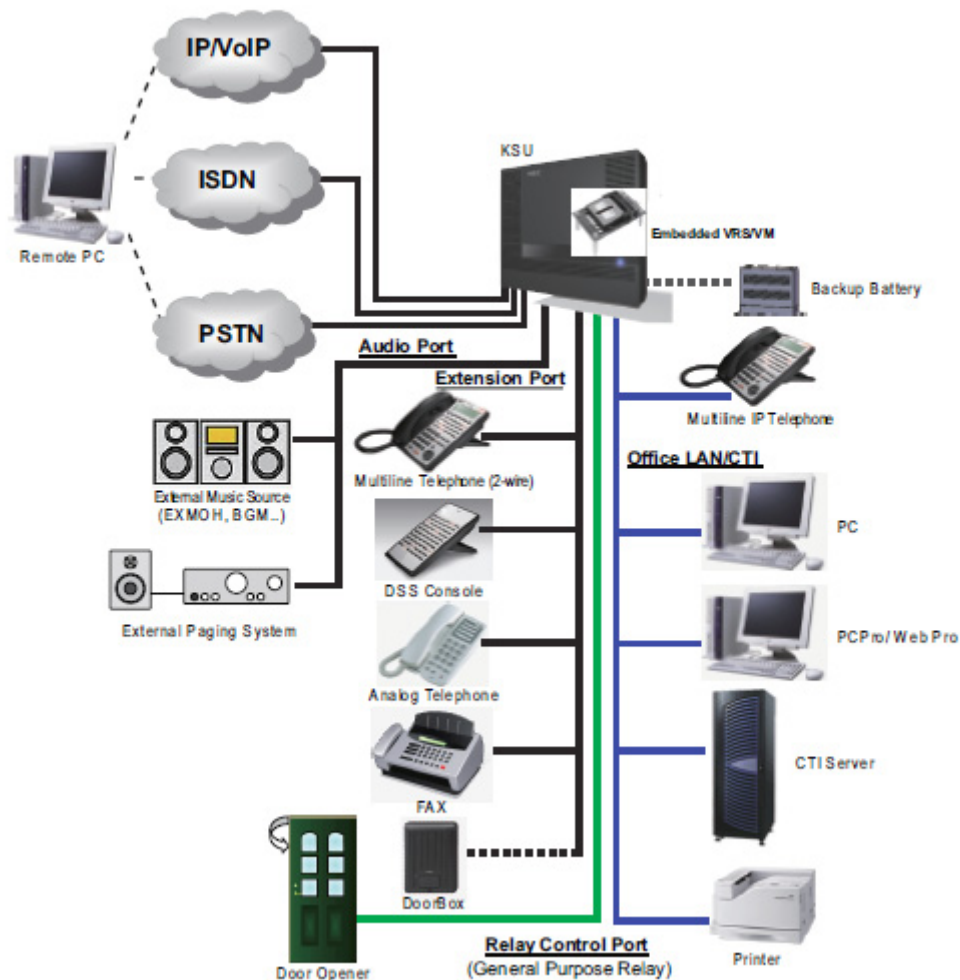

Figure 1-1 System Configuration

SECTION 2 EQUIPMENT LIST

The following table lists all equipment for the SL1100 system.

Stock Number	Equipment Name	Equipment Description	Note
8503498	SL1100 TDM Basic Kit (For AT)	SL1100 TDM Basic Kit <Including> IP4AT-1228M-B KSU, PZ-VM21, IP4WW-CFVMS-C1, IP4WW-12TXH-B-TEL (BK) (3 sets)	
8503499	SL1100 IP Basic Kit (For AT)	SL1100 IP Basic Kit <Including> IP4AT-1228M-B KSU, PZ-VM21, IP4AT-MEMDB-C1, IP4WW-VOIPDB-C1, IP4WW-CFVMS-C1, IP4WW-24TIXH-C-TEL (BK) (3 sets)	
4427000	IP4AT-1228M-B KSU	IP4AT-1228M-B KSU with AC Cable (for AT) <Including> IP4AT-CPU-B1, IP4AT-084M-B1, Power Supply	
4427005	IP4WW-Battery Box	External Battery Box without Batteries	
4427007	IP4WW-080E-B1	8 Digital Extensions Interface	
4427008	IP4AT-008E-B1	8 Analogue Extensions Interface	
4427012	IP4WW-000E-B1	Extension board for 2BRIDB or 4COIDB daughter board	
4427010	IP4WW-4COIDB-B1	4 Analogue Trunks Interface, mounted on 084M-B1/080E-B1/008E-B1/000E-B1 board	
4427011	IP4WW-2BRIDB-C1	2 Basic Rate Interface, mounted on 084M-B1/080E-B1/008E-B1/000E-B1 board	
4427009	IP4WW-1PRIU-C1	1 Primary Rate Interface (PRI)	
4427006	IP4AT-MEMDB-C1	Memory Expansion on CPU (for AT)	
4427001	IP4WW-VOIPDB-C1	16-channel VOIP on CPU	
4422011	PZ-VM21	16 Channels for Voice Mail with a Single Channel V.34 Modem	
4427003	IP4WW-CFVMS-C1	Compact Flash for VRS and InMail (Approx. 15 hours, VRS: 4ch (default)/InMail: 2ch (default))	
4427100	IP4WW-12TXH-B-TEL (BK)	2-wire 12-key Multiline Telephone	
4427101	IP4WW-24TXH-B-TEL (BK)	2-wire 24-key Multiline Telephone	
4427102	IP4WW-24TIXH-C-TEL (BK)	24-Keys, Multiline IP Telephone	
4427103	IP4WW-60D DSS-B CONSOLE (BK)	60-button Direct Station Selection (DSS) Console	
4427104	IP4WW-WALL MOUNT UNIT	Wall-Mount Unit for IP4WW-24TIXH-C-TEL	
800188	DP-D-1D	Doorphone	
4523424	ACA-UA UNIT	AC/DC Adapter for 24TIXH TEL	
4424054	AC-LE UNIT		
4426166	SL-IP-SIPTRK-1 LIC	SIP Trunk License (1 port)	
4426167	SL-IP-SIPEXT-1 LIC	Standard SIP Terminal License (1 port)	
4426168	SL-IP-ENCRYPTION LIC	Encryption License for Multiline IP Telephone (1 license per system)	
4426169	SL-IP-NAPT LIC	NAPT License for Multiline IP Telephone (1 license per system)	
4426170	SL-VM-CHANNEL-2 LIC	Additional InMail Channel License (2 ports)	
4426171	SL-VM-ADVANCE LIC	InMail Advanced Features License (1 license per system)	
4426172	SL-SYS-MOBILE-1 LIC	Additional Mobile Extension Port License (1 port)	
4426173	SL-SYS-HOTEL LIC	Hotel/Motel Feature License (1 license per system)	

2.1 KSUs and Optional Unit

2.1.1 IP4[]-1228M-B KSU

The Main or controlling KSU is shipped fully assembled. The following are included with the KSU:

- CPU with main software (CPU-B1)
- Power supply (110V/240V)
- 1 External backup battery connector
- 2 mounting spaces for 080E/008E/000E/1PRIU
- 8 digital and 4 analogue extension I/F (084M-B1)
- 1 mounting space for 4COIDB-B1 or 2BRIDB-C1
- 2 general purpose relays
- 1 audio output for Paging (mini-jack)
- 2 audio inputs for ExMOH/BGM (mini-jack)
- SLT ringer
- Message waiting lamp driver



The on-board DSP provides:

- 16 telephony resources (DTMF/Dial tone/Busy tone/FSK caller-ID receiver/sender)
- 128 tone sender resources (System tones sender/DTMF sender)
- 32 ch conference resources

2.1.2 IP4WW-Battery Box

Connected to KSU power supply, the external backup battery provides DC power in case a loss of AC power occurs. An optional (locally procured), external battery source can be used to provide power during a power failure.

- Connect this box to the power supply at KSU.
- Wall/floor-mountable
- One KSU can be mounted on the Battery box.
- Backup duration is approximately one hour.



2.2 Trunk/Extension/ISDN Expansion Interface Cards

2.2.1 IP4WW-080E-B1

The 080E card is installed in the 1228M KSU and provides a total of eight digital ports. Either the analogue trunk daughter board (4COIDB) or the ISDN BRI daughter board (2BRIDB) can be mounted on this card.

- Install this card to the expansion card slot at Main KSU.
- Enables the DSS console to connect to any extension port.
- One analogue trunk or ISDN BRI daughter board connection.

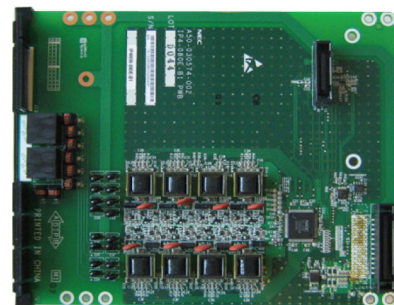

2.2.2 IP4[]-008E-B1

This 008E card is installed in the 1228M KSU and provides a total of eight analogue ports. Either the analogue trunk daughter board (4COIDB) or the ISDN BRI daughter board (2BRIDB) can be mounted on this card.

- Install this card to the expansion card slot at Main KSU.
- One analogue trunk or ISDN BRI daughter board connection.

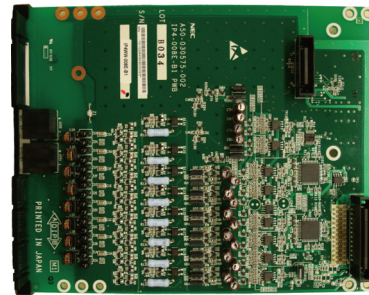

2.2.3 IP4WW-000E-B1

This 000E card is an expansion card and installed in the 1228M KSU. Either the analogue trunk daughter board (4COIDB) or the ISDN BRI daughter board (2BRIDB) can be mounted on this card.

- Install this card to the expansion card slot at Main KSU.
- One analogue trunk or ISDN BRI daughter board connection.

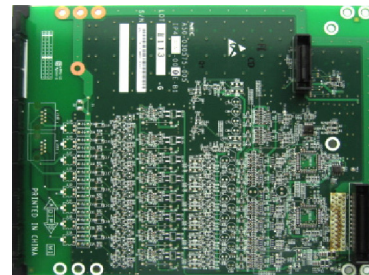

2.2.4 IP4WW-4COIDB-B1

The 4COIDB provides four analogue trunk and is mounted on the 084M, 080E, 008E or 000E card. A total of three 4COIDBs can be installed per system.

- Mount this board onto the 084M, 080E, 008E or 000E card.
- 1 power failure transfer circuit

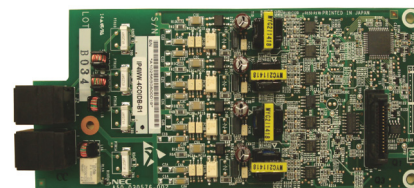

2.2.5 IP4WW-2BRIDB-C1

The 2BRIDB provides two ISDN (Basic Rate) circuit and is mounted on the 084M, 080E, 008E or 000E card. A total of three 2BRIDBs can be installed per system.

- Mount this board onto the 084M, 080E, 008E or 000E card.
- Supports T/S point connection (Hard-switch).
- All ISDN circuits are not supplied with DC power from the system.

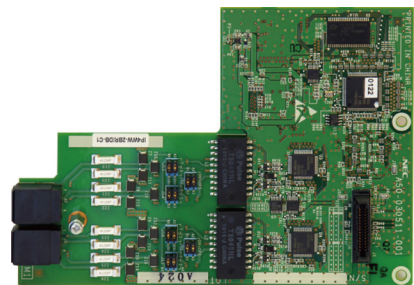

2.2.6 IP4WW-1PRIU-C1

The 1PRIU is installed in the 1228M KSU providing for an ISDN Primary Rate Interface. A total of one 1PRIU can be installed per system.

- Install this card to the expansion card slot at Main KSU.
- Supports T/S point connection (Hard-switch).

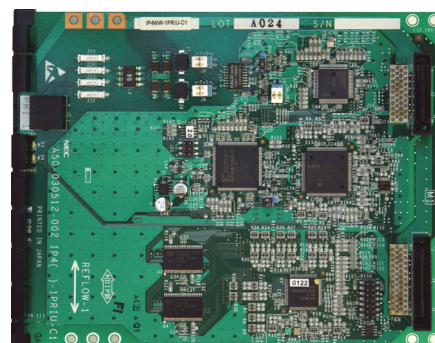

2.3 Optional Interface Cards

2.3.1 IP4[]-MEMDB-C1

This card provides additional expansion memory. Following memories are equipped on this card.

Table 1-1 Memory Capacity of MEMDB-C1

Memory Type	Capacity
SDRAM	64 MB
Flash Memory	32 MB

The MEMDB is mounted on the CPU card and provides the SDRAM and Flash Memory required by the following:

- VoIP
- CTI
- VRS and InMail Channel Increment above 8 channels.
- Virtual Loopback
- InMail Email Notification

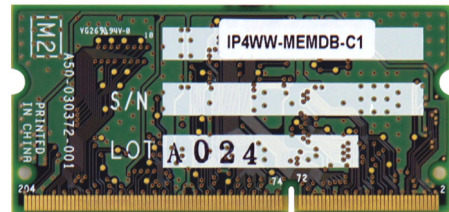

2.3.2 IP4WW-VOIPDB-C1

The VOIPDB-C1 card provides the RTP/RTCP voice processing function.

- Mount this card onto the CPU card (VoIPDB slot) at Main KSU.
- Max. 16 channels.

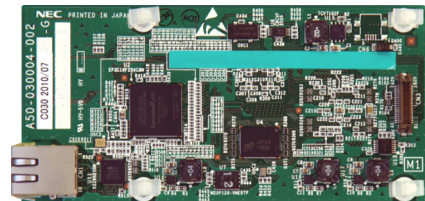

2.3.3 PZ-VM21

The PZ-VM21 daughter board provides additional Voice Response and Voice Mail functionality using a Compact Flash (CF) interface and a single channel V.34 modem.

- Mount this card onto the CPU card (VMDB slot) at Main KSU.
- V.34 (33.6kbps) analogue modem is initially mounted (for remote maintenance).
- VRS/VM CF card is optional.

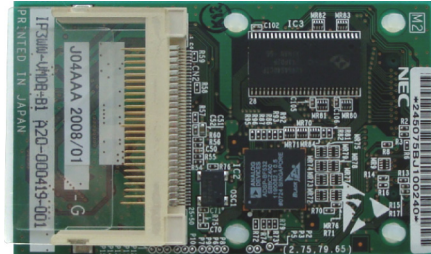

2.3.4 IP4WW-CFVMS-C1

VRS/VM CF card is available:

- Install into the PZ-VM21 mounted on the CPU card at Main KSU.
- CFVMS: 4-channel VRS and 2-channel VM as default. (Approx. 15 hours)



2.4 Multiline Telephones and Optional Equipment

2.4.1 IP4WW-12TXH-B TEL

The 12TXH-B TEL is a 2-wire digital multiline telephone featuring:

- Programmable keys: 12
- Soft Keys: 4
- LCD: 24 digits x 3 lines with Backlit
- Handsfree: Full-duplex
- Backlit dial pad: Yes
- Angle Adjustment: 2-steps
- Wall-Mounting kit: Built-in
- Headset Port: Yes



2.4.2 IP4WW-24TXH-B TEL

The 24TXH-B TEL is a 2-wire digital multiline telephone featuring:

- Programmable keys: 24
- Soft Keys: 4
- LCD: 24 digits x 3 lines with Backlit
- Handsfree: Full-duplex
- Backlit dial pad: Yes
- Angle Adjustment: 2-steps
- Wall-Mounting kit: Built-in
- Headset Port: Yes



2.4.3 IP4[J]-24TIXH-C TEL

The 24TIXH-C TEL is an IP multiline telephone featuring:

- Programmable keys: 24
- Soft Keys: 4
- LCD: 24 digits x 3 lines with Backlit
- Handsfree: Full-duplex
- Interface: 2 x RJ45 Ethernet Ports (10Base-T/100Base-TX) for LAN and PC
- Power Feeding: AC Adapter (optional) or PoE (IEEE802.3af)
- Support CODEC: G.711/G.729a/G.722
- Backlit dial pad: Yes
- Angle Adjustment: 2-steps
- Wall-Mounting kit: IP4WW-WALL MOUNT UNIT (Optional)
- Headset Port: Yes



2.4.4 IP4WW-60D DSS-B

The DSS console gives a multiline terminal user a Busy Lamp Field (BLF) and one-button access to extensions, trunks and system features. Mainly designed for operator use, the 60-button DSS console provides an additional 60 programmable keys.

- Connect this console to digital extension port at 084M/080E of KSU.
- Programmable keys: 60
- Angle Adjustment: 2-steps
- Wall-Mounting kit: Built-in



2.4.5 DP-D-1D

This is the Doorphone Box.

- Connects to analogue port number 3 or 4 on the 084M of KSU.



SECTION 3 SYSTEM CAPACITY

3.1 System Capacity

Table 1-2 System Capacity

Items		1 KSU (1228)	Description	Note
Expansion Slot		2		
System Maximum Port		58	1KSU: 084M+PRI+080E+4COIDBx2	
Trunk Port Max.		38	1KSU: PRIx1+4COIDB/BRIx2	
Trunk Port	Analogue Trunks (COT)	12	1KSU: 4COIDBx3 on 084M/080E/008E/000E	
	BRI (T-Point)	12	1KSU: 2BRIx3 on 084M/080E/008E/000E	
	PRI (30B)	30	Max. one PRI	
	IP Trunk (SIP)	16	When MEMDB is Installed	
Station Port Max.		40	1KSU: 084M+080Ex2+BRIx3	
Station Port	2W Key Set	24	Max. 24/KSU 084M+080Ex2	
	SLT (-28V)	20	1KSU: 084M+008Ex2	
	BRI (S-Point)	12	1KSU: BRIx3 on 084M/080E/008E/000E	
	2W DSS Console	12	Connect to digital extension Port at 084M/080E	
	Doorphone	2	2DPH I/F on 084M (analogue extension port 3, 4) Alternative use with SLT	
	SIP-MLT/ SIP Std. terminal	16	When MEMDB is Installed	
	VM/VRS Channels	2 VM ports/ 4 VRS ports (default) (Total Max.8 w/o MEMDB or 16 w/MEMDB)	CFVMS-C1 VM Port increased by license.	
Virtual Extension		50		
Relay		2	2 circuits on 084M	
Power Failure Transfer		3	1 PFT circuit on 4COIDB (COI port 1 and PF port)	
External Paging (Audio Out)		1	1 audio-In/Out and 2 audio-In circuits on 084M.	
External MOH (Audio In)		1	Select one of 084M for MOH/BGM.	
External BGM (Audio In)		1		
Ethernet Port		1	1 circuit on CPU	
VoIP Channels		16	When MEMDB is Installed	
V.34 Modem		1	1 circuit on PZ-VM21	
Conference Circuits		32 (Max. 16 parties per Conference)		
DSP Resource ¹		16	For 1228M KSU (DSP on CPU)	
		16	When PZ-VM21 is installed	
DSP Sender ²		128		

¹ Service Tone receiver, DTMF receiver, Caller ID sender / receiver, MF receiver, MFC receiver

² Service Tone sender, DTMF sender, MF sender, MFC sender

3.2 KSU Capacity

System image of KSU capacity (ISDN, Trunk, Extension) is shown as below.

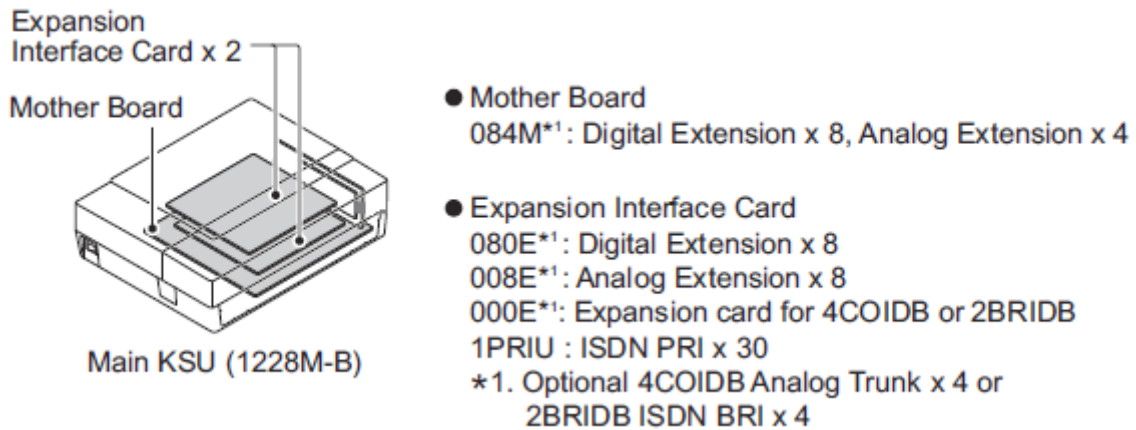

Figure 1-2 System Image

3.2.1 Expandability of Trunk and Extension (without PRI)

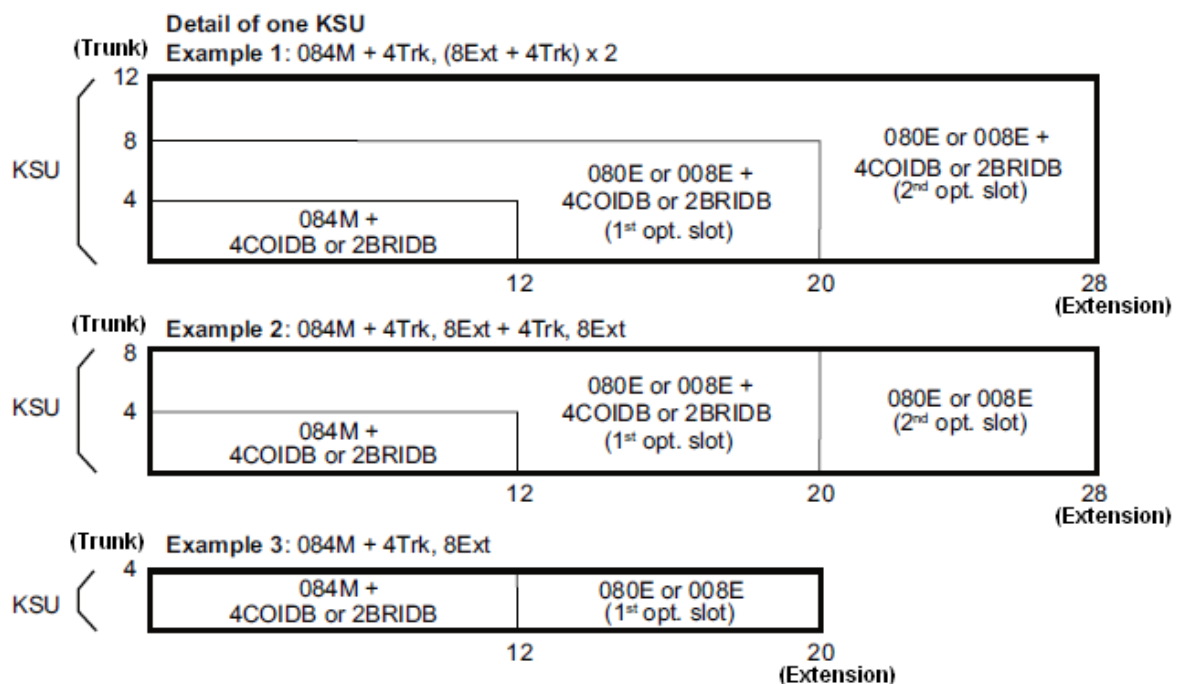

Figure 1-3 Maximum KSU Capacity - Expandability of Trunk and Extension (without PRI)

3.2.2 Expandability of Trunk and Extension (with PRI)

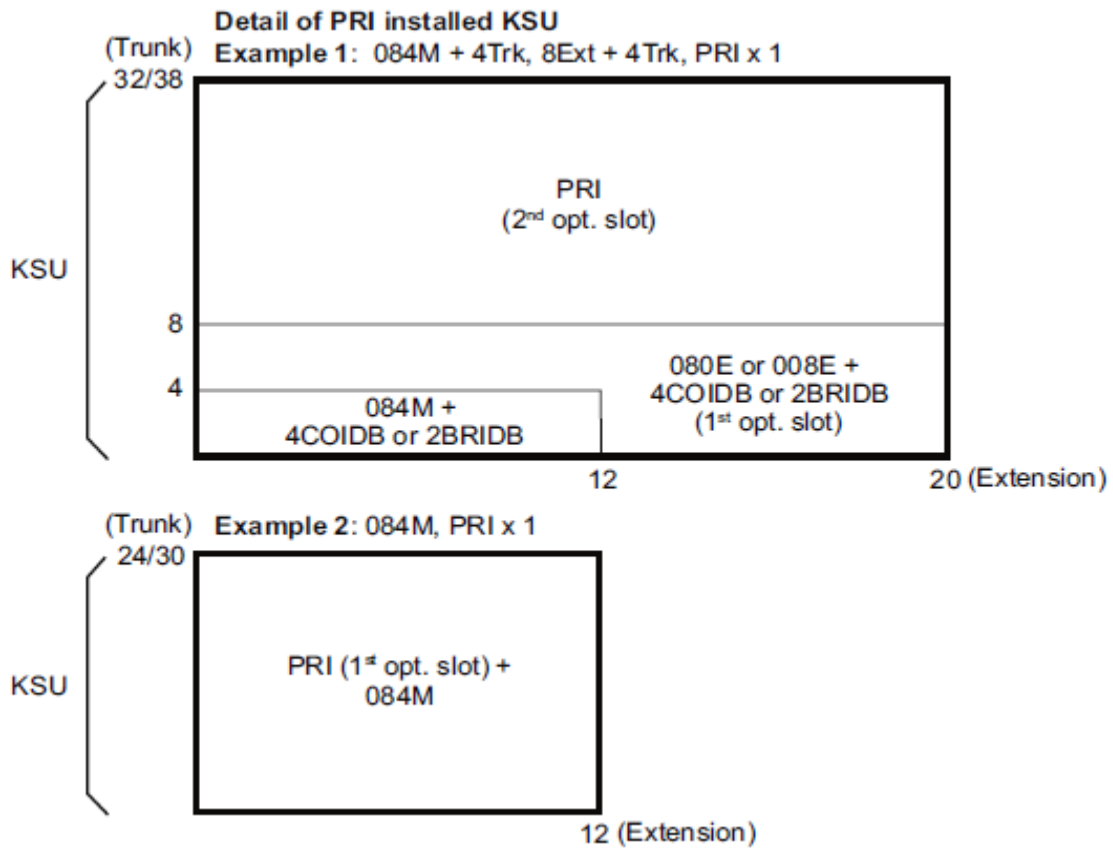

Figure 1-4 Maximum KSU Capacity - Expandability of Trunk and Extension (with PRI)

Installation

SECTION 1 INSTALLING THE MAIN KSU

1.1 Before Installing the KSU

1.1.1 General Precautions

- To avoid shock or equipment damage, do not plug in or turn the system power on before completing the installation process.
- Avoid working with the Equipment during electrical storms.
- Use only commercial AC power to prevent shock or fire.
- Use the power cord supplied with the KSU.
- Install batteries with the correct polarity to prevent damaging equipment.
- Never install telephone wiring during a lightning storm.
- Never install telephone jacks in wet locations unless the jack is specifically designed for wet locations.
- Never touch uninsulated telephone wires or terminals unless the telephone line is disconnected at the network interface.
- To avoid damage, the KSU should not be placed on unstable surfaces.
- To prevent overheating, do not bundle AC power cords together.
- Make sure the KSU has proper Earth ground.

1.1.2 Preparations

- Make sure the necessary tools (screw driver set, pliers set, etc) are available.
- Make sure you have a building plan showing common equipment, extensions, the telecom demarcation, and earth ground location. The installation site must meet the following site / environmental requirements.

1.1.3 Site Requirements

Main KSU can have the optional Battery Box connected, before deciding on the mounting location refer to 1.3 Wall-Mounting the KSU and Section 2 INSTALLING THE EXTERNAL BACKUP BATTERY.

- The system without the IP4WW-Battery Box should be wall-mounted only. The system with the IP4WW-Battery Box can be installed on either the floor or wall (horizontally). Ensure enough space exists to allow the installation of KSU and/or battery box.
- A dedicated 100V-120V/220V/230V/240VAC circuit located within two meters of the KSU is required. A separate dedicated AC outlet is necessary for the KSU.

1.1.4 Environmental Requirements

Meeting established environmental standards maximizes the life of the system. Make sure that the site is not:

- In direct sunlight or in hot, cold or humid places.
- In dusty areas or in areas where sulfuric gases are produced.
- In places where shocks or vibrations are frequent or strong.
- In places where water or other fluids comes in contact with the equipment.
- In areas near high-frequency machines or electric welders.
- Near computers, telexes, microwaves, air conditioners, etc.
- Near radio antennas (including shortwave).

1.1.5 Unpacking

Unpack the KSU and check it against the following list. Inspect for physical damage.

Table 2-1 KSU Packing List

Items	List of Contents	QTY
1228M-B KSU	1228M-B KSU	1
	AC Power Cord	1
	Screws (M4.1x25)	4
	Wall-Mounting Template	1
	End User License Agreement (EULA)	1

1.2 Installing the Main KSU (1228M-B KSU)

The Main KSU has a CPU-B card, an eight digital and four analogue extension Interface, a control relay circuit for External devices, and two mounting spaces for optional cards (080E-B1/008E-B1/000E-B1/1PRIU-C1).

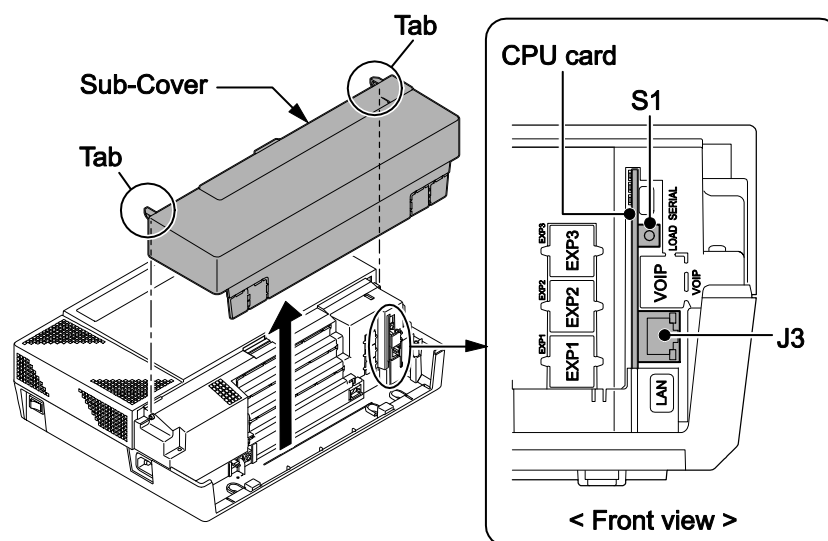

Figure 2-1 CPU Card Location

Table 2-2 Items on the CPU card

Item	Description	
S1 (LOAD)	Switch for System Restart/System Reset (Cold start occurs)/Upload Software	
<p>J3 (RJ45) 87654321</p>	Ethernet Cable Connection (for SMDR (PC, Printer), PCPro or WebPro....etc)	
	Pin No.	Connection
	1	Tx+
	2	Tx-
	3	Rx+
	4	-
	5	-
	6	Rx-
	7	-
8	-	

For the detail of LED (D1 - D5), refer to Inserting the CF Card and CPU LED Indications.

1.3 Wall-Mounting the KSU

1.3.1 KSU Dimensions

For Dimensions of the 1228M-B KSU, refer to Figure 2-2 Dimension of the Main KSU.

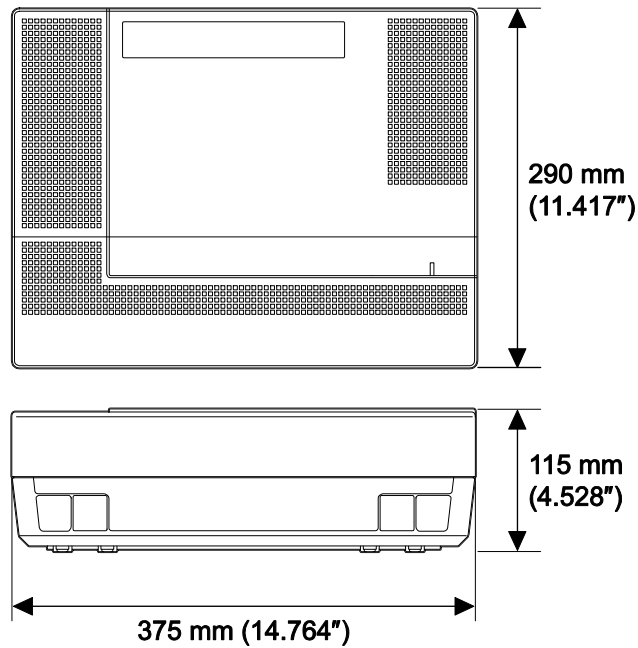

Figure 2-2 Dimension of the Main KSU

1.3.2 Wall Installation of KSU

The Main KSU (1228M-B) can be mounted on the wall. Before installing, ensure the appropriate spacing exists as shown below.

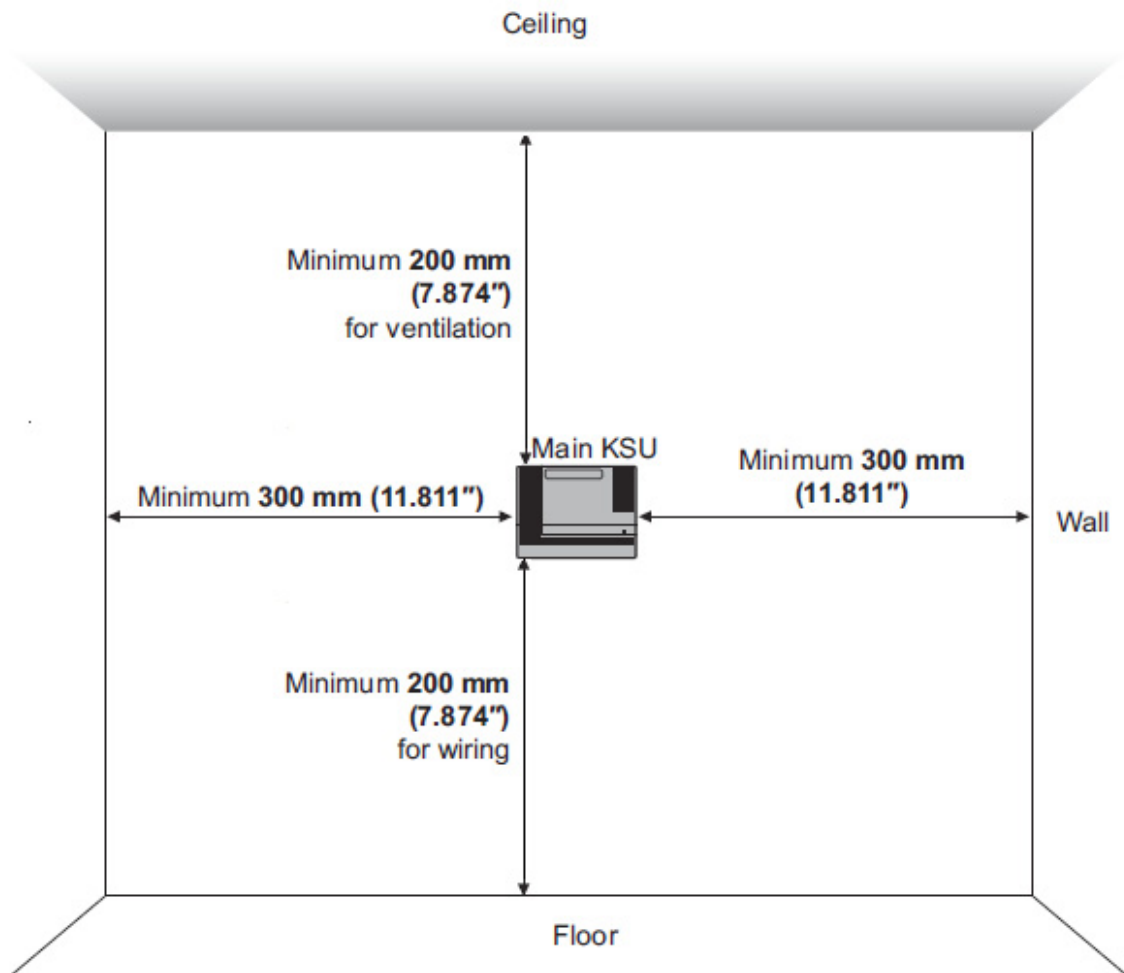

Figure 2-3 Wall Mount of KSU



In the case, the KSU is mounted on Battery Box, refer to 2.6.2 Wall-Mounting the IP4WW-Battery Box.

1.3.3 Mounting Procedure of KSU



One Main KSU can be mounted per IP4WW-Battery Box. For the mounting, refer to 2.6.3 Mounting One KSU on the Battery Box.

1. Place the attached template on the wall to mark the four screw positions.

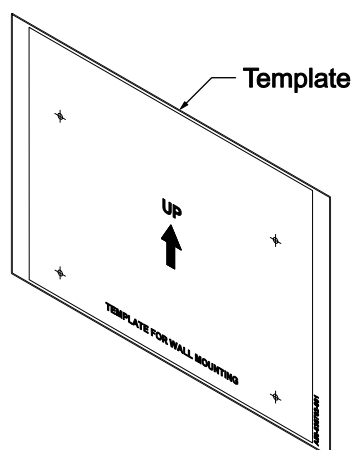

Figure 2-4 Wall-Mounting Template

2. Install four screws into the wall. The screw heads must stand off from the wall about 2.5 mm (0.098") to 3.5 mm (0.138").

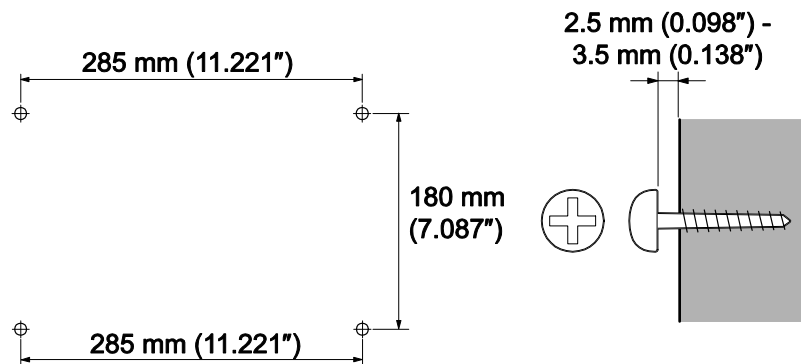

Figure 2-5 Screw Positions

- Wall-Mounting Screws (M4.1x 25: 4 pcs) are attached to the KSU.
 - The screw diameter is 4 mm (0.158") to 4.5 mm (0.177").
3. Push the center of the Sub-Cover and slide it outward.

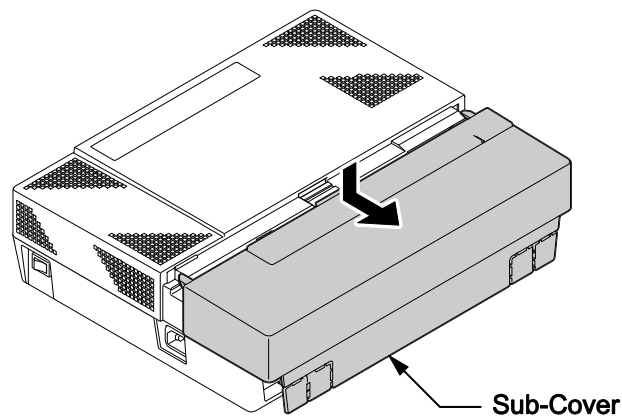

Figure 2-6 Sub-Cover Slide-out

4. Pull out the Sub-Cover by pushing out the tabs.

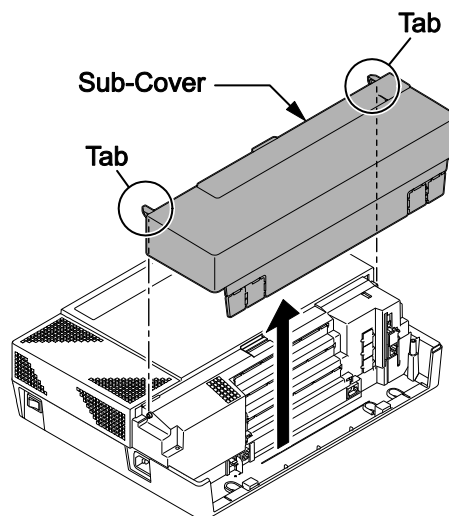

Figure 2-7 Removing the Sub-Cover

- The Sub-Cover can be opened and held in the open position.

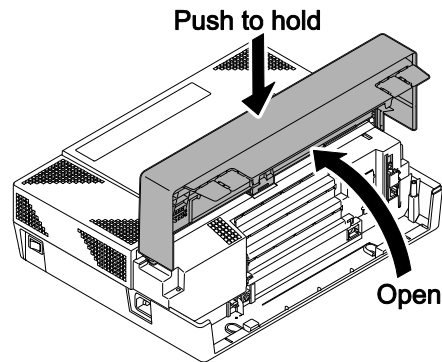

Figure 2-8 Sub-Cover Open Position

5. Align the four holes on the back of the KSU with the four screws installed in the wall.

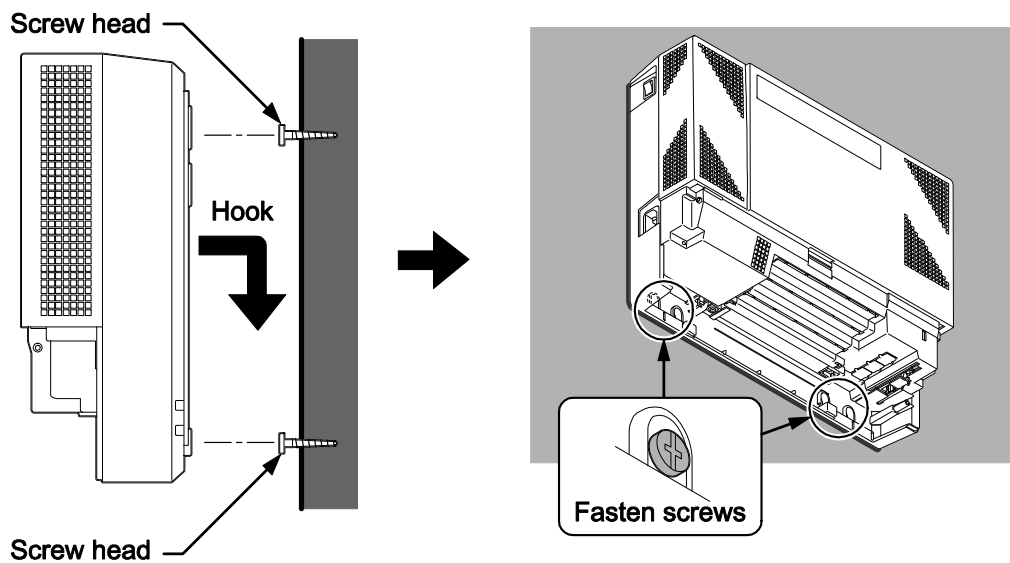

Figure 2-9 Mounting the KSU

6. Slide the KSU into position and tighten the lower two screws.

1.4 Grounding and AC Cabling

The ETH (Earth Ground Lug) is located near the power supply on the KSU. The Sub-Cover must be opened in order to access to it.

1.4.1 Grounding the KSU



Ensure Main KSU are powered off and unplug the AC cord.

In the KSU, connect the ETH lug to the verified grounding point using a minimum cable size of 14AWG ($\Phi 2.0$ mm) wire.

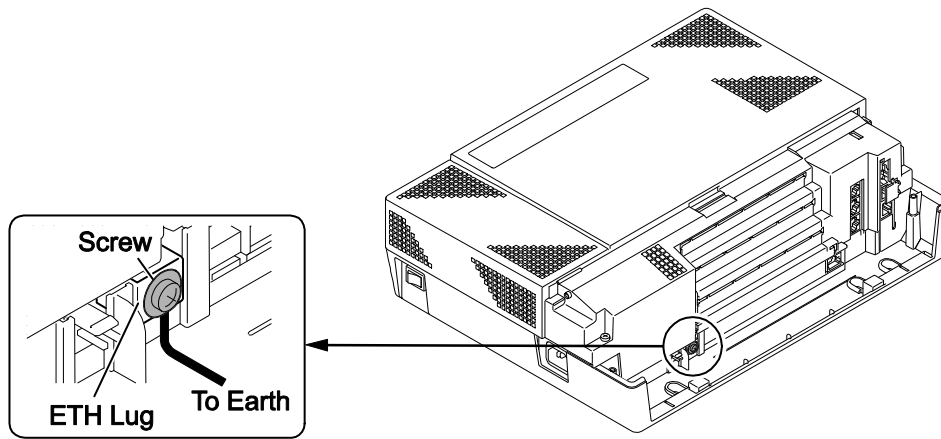

Figure 2-10 ETH Lug

- The grounding cable is supplier-provided.(not attached to the system)

 1. Loosen the screw.
 2. Insert a grounding wire (user supplied).
 3. Tighten the screw.
 4. Connect the grounding wire to earth ground.

! *Proper grounding is very important to protect the system from external noise and to reduce the risk of electrocution in the event of a lightning strike.*

1.4.2 AC Power Requirement

A dedicated 100V-120V/220V/230V/240V 50/60Hz circuit located within two meters of the KSU is required. A separate dedicated AC outlet is necessary for the KSU.

! *Double Pole/Neutral Fusing
(Power supply fuses are located at both the L and N side.)*

Table 2-3 Power Requirement

	110VAC	120VAC	220VAC	230VAC	240VAC
Power Requirement	110 VAC@15 A	120 VAC@15 A	220 VAC@15 A	230 VAC@15 A	240 VAC@15 A
Power Consumption	Main KSU = 128 VA	Main KSU = 130 VA	Main KSU = 154 VA	Main KSU = 154 VA	Main KSU = 156 VA
Input Voltage (Rated Voltage)	90 VAC to 264 VAC (100VAC/120VAC/220VAC/230VAC/240VAC)				
Frequency	47 Hz - 63 Hz (Rated Frequency: 50/60 Hz)				
Phase and Wire	Single Phase, 2 Line + PE Type				
Ground Requirement	No.14 AWG Copper Wire				
Feeding Voltage	SLT: 20 mA/ -27 V				
AC Input I	Main KSU = 1.16 A	Main KSU = 1.08 A	Main KSU = 0.70 A	Main KSU = 0.67 A	Main KSU = 0.65 A
KWh	Main KSU = 0.128 KWh	Main KSU = 0.130 KWh	Main KSU = 0.154 KWh	Main KSU = 0.154 KWh	Main KSU = 0.156 KWh
BTU (KWh x 3413)	Main KSU = 437 BTU	Main KSU = 444 BTU	Main KSU = 526 BTU	Main KSU = 526 BTU	Main KSU = 532 BTU

1.4.3 AC Power Cord

The AC power switch and AC power inlet are located at the left side of the KSU. The AC power cord is connected to the AC inlet and the commercial AC power socket.

! *Do not plug-in AC power cord if the KSU Cover is removed.*



Before connecting the AC power cord, make sure:

- *The power switch at the left side of the KSU is turned **OFF**.*
- *The power switch at the commercial AC power socket is turned **OFF**.*
- *The AC plug fits the commercial AC power socket. The plug adapter is necessary if it does not fit.*

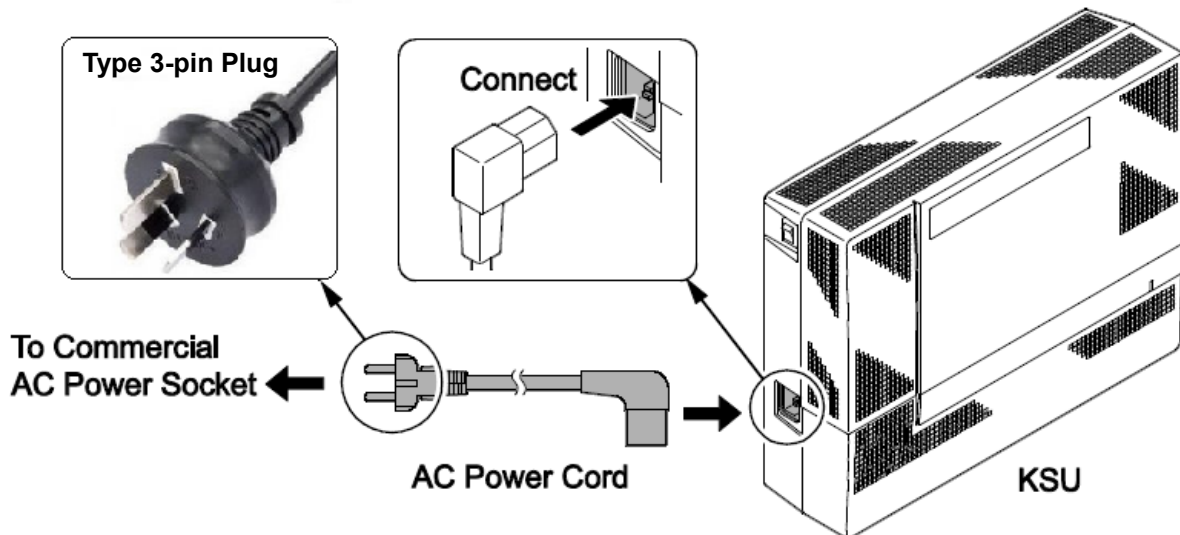

Figure 2-11 AC Power Cord



KSU must have its own commercial AC power socket.



***DO NOT POWER ON** until KSU installation has been completed.*

1.5 Trunk/Extension Cabling

1.5.1 General

The system provides RJ61 modular jacks for analogue/digital extension connections.

1.5.2 Precautions for Cabling

- Do not wire the cable with an AC cable, computer, etc.
- Do not run the cable near a high frequency generating device.
- Use cable protectors in case the cables are run on the floor.
- Aerial distribution wiring is not allowed.
- Trunks must be installed with lightning protectors.
- Do not install the Topaz Terminal in the SL1100 system, it does not work properly.

1.5.3 Trunk Cabling



Trunk cabling is required for the 4COIDB, 2BRIDB or 1PRIU PCBs.

*Refer to **INSTALLING THE EXPANSION INTERFACE CARDS** for mounting and cabling 4COIDB, 2BRIDB and 1PRIU PCBs.*

1.5.4 Extension Cabling

The 084M-B1 PCB within the KSU provides two "RJ61" modular jacks for digital extension (8ports) and one for analogue extensions (4ports).

! *Before plugging in the Multiline Telephone, DSS Console, Single line Telephone or Doorphone, ensure Main KSU is powered off.*

! *Only SL1100 terminals (12TXH, 24TXH) may be connected to a SL1100 digital port. Do not connect any other terminal as damage may result.*

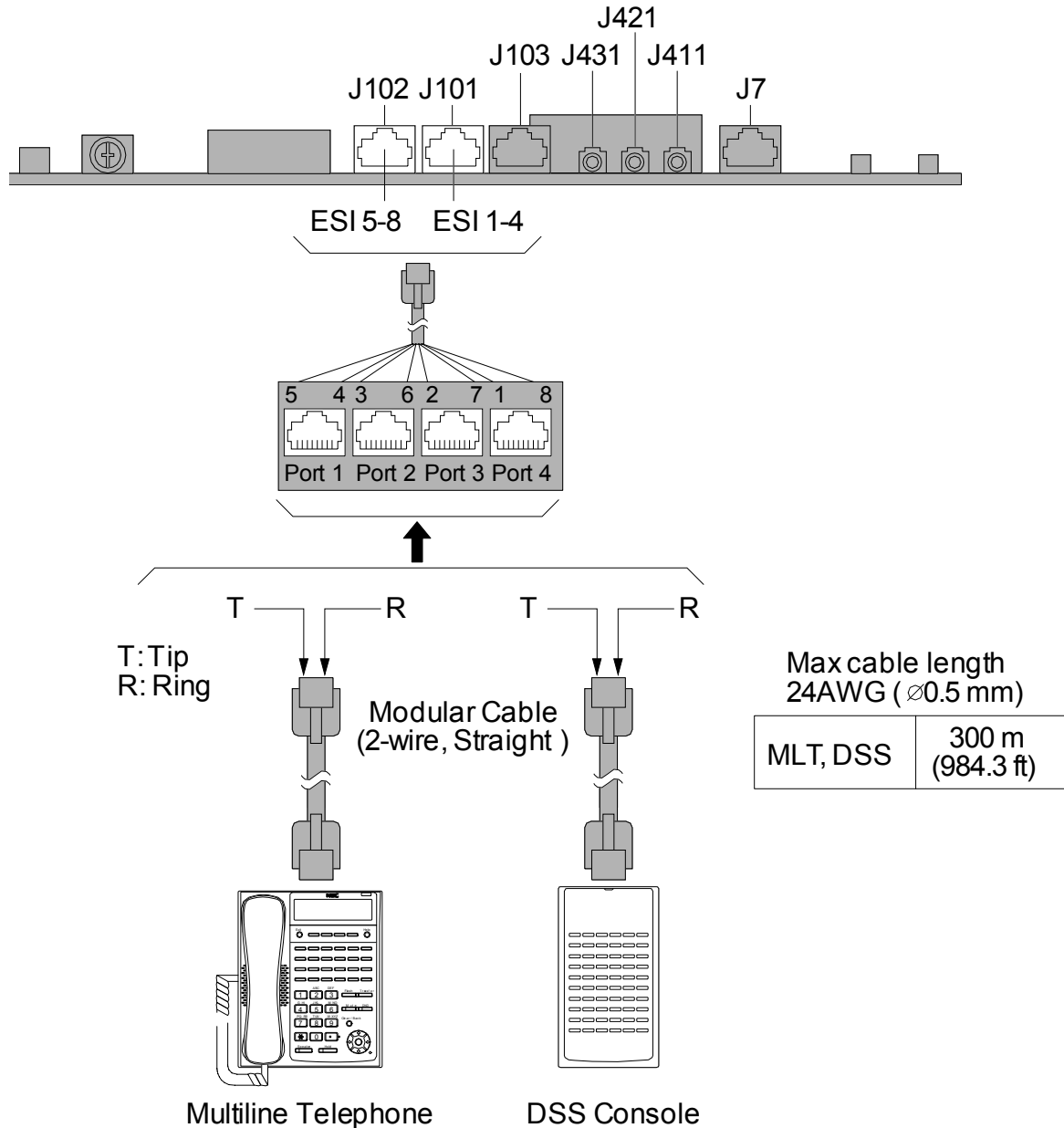

Figure 2-12 Digital Extension Cabling

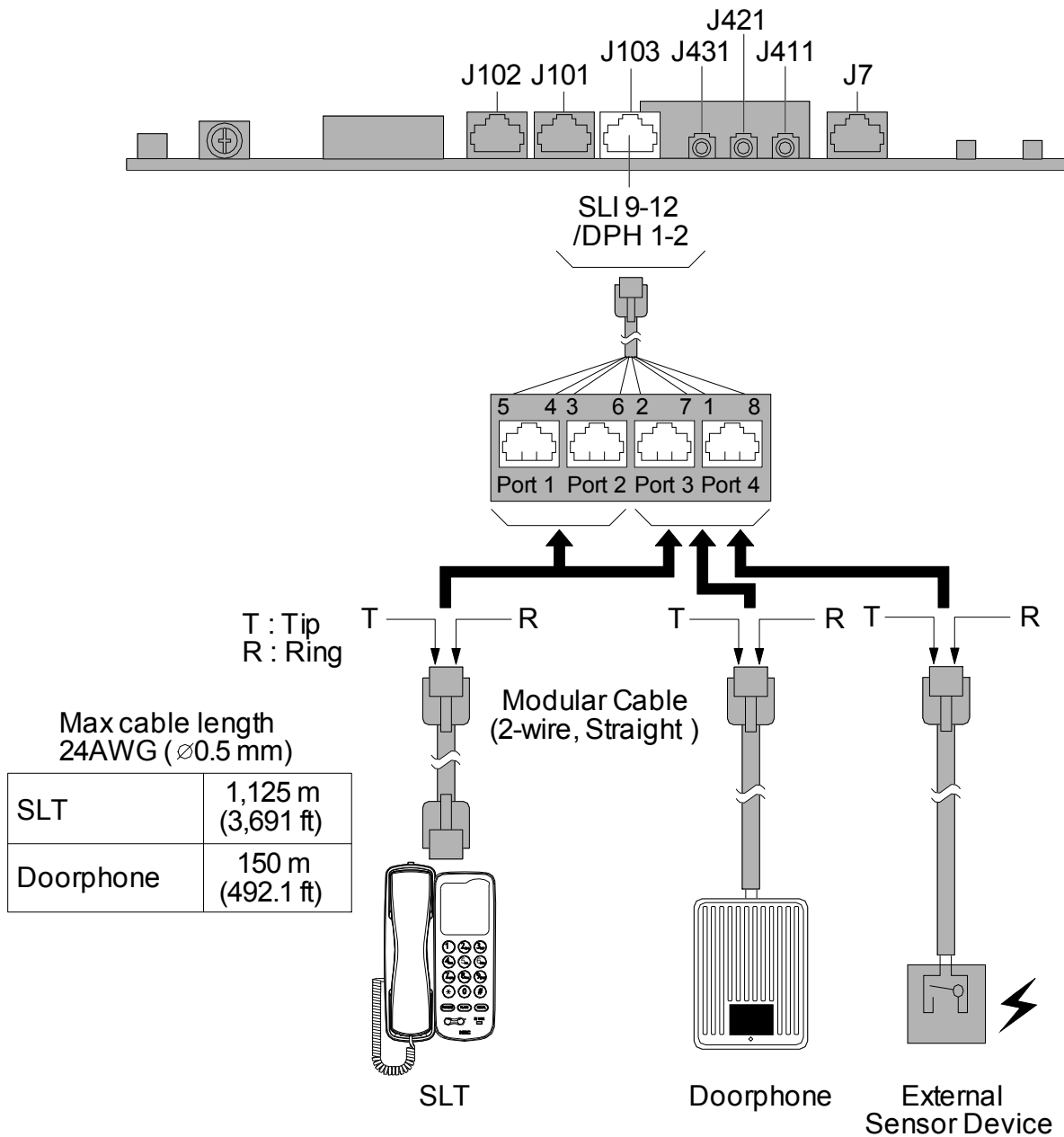

Figure 2-13 Analogue Extension Cabling



While a Digital/Analogue Telephone (port) is ringing or MW-lamp is flashing on a Digital/Analogue Phone (port), do not disconnect the phone from the port or connect another type of the terminal to this port.



Doorphone/External Sensor Device must be connected to the No. 3 or 4 PORT of the RJ61 connector for Analogue extensions on each 084M-B1.



Setting program 10-03 to "Door Phone" is required when connecting a Door phone Box or Sensor device.

1.5.4.1 Connectors

The following table shows the pin-outs for the RJ-61 cable connector for Digital/Analogue extension connections.

Table 2-4 RJ61 Cable Connector Pin-Outs (J101-J103)

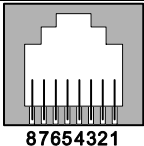
	Pin No.	ESI 1-4 (J101), ESI 5-8 (J102): 2-Wire Digital Extension Port Connector (RJ-61)	SLI 9-12/DPH 1-2 (J103): Analogue Extension Port Connector (RJ-61)
 <p>87654321</p>	1	T4 (Tip for port 4)	T4 (Tip for port 4)
	2	T3 (Tip for port 3)	T3 (Tip for port 3)
	3	T2 (Tip for port 2)	T2 (Tip for port 2)
	4	R1 (Ring for port 1)	R1 (Ring for port 1)
	5	T1 (Tip for port 1)	T1 (Tip for port 1)
	6	R2 (Ring for port 2)	R2 (Ring for port 2)
	7	R3 (Ring for port 3)	R3 (Ring for port 3)
	8	R4 (Ring for port 4)	R4 (Ring for port 4)

1.5.5 Cable Routing and Clamping

1. Depending on cabling requirement, select either a right or left route. Clamp and route cable to outside.

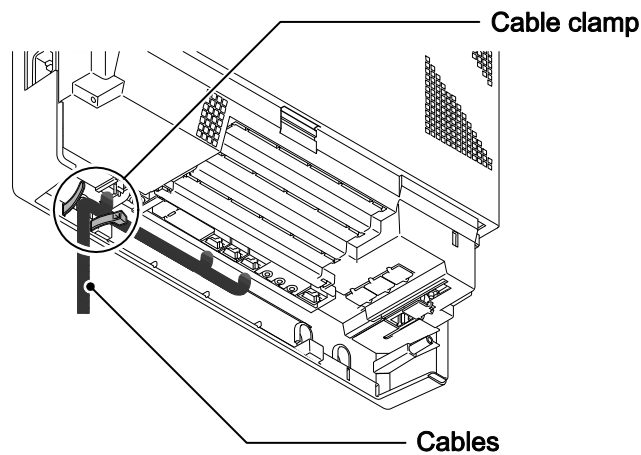

Figure 2-14 Cabling

2. Cut and remove the Plastic Knockouts as needed from the Sub-Cover.

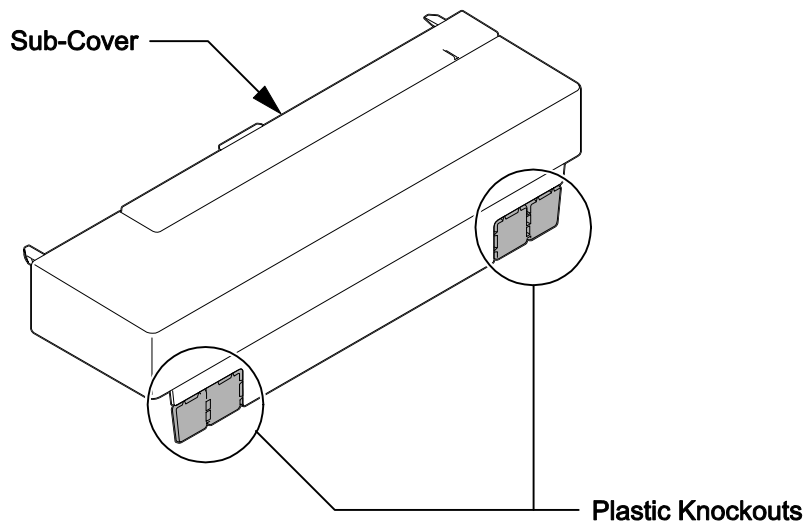

Figure 2-15 Sub-Cover

3. Replace the Sub-Cover.

SECTION 2 INSTALLING THE EXTERNAL BACKUP BATTERY

2.1 General

The external backup battery box (IP4WW-Battery Box) with batteries provides power to the system when AC power fails. It is connected to the power supply of the KSU.



An optional (locally procured), external battery source can be used to provide power during a power failure.



One KSU must have own IP4WW-Battery Box.



***Do not connect the DX2E-32i/NX7E Topaz Battery Box to the SL1100 system.
Damage to equipment or property may result.***

2.2 Unpacking

Unpack the IP4WW-Battery Box and check it against the following list. Inspect for physical damage.

Table 2-5 IP4WW-Battery Box Packing List

Items	List of Contents	QTY
IP4WW-Battery Box	Battery Box	1
	Battery Connection Cable (Black & Red)	1
	Battery Connection Cable (Blue)	1
	Screws: M4 x 8	10
	M3 x 6 with Washer	1
	Screws: M4.1 x 16	6
	Battery Box FM/WM Base-F	1
	Battery Box FM/WM Base-R	1
	Battery Box WM Support	1
	Battery Box WM Hook	1

2.3 Battery Box Dimensions

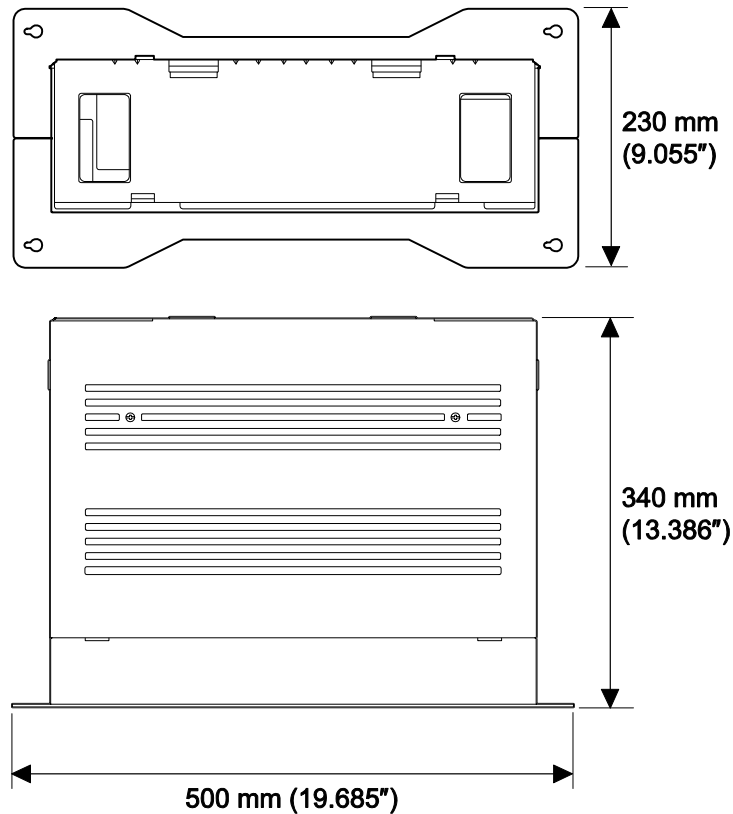

Figure 2-16 Dimension of the IP4WW-Battery Box

2.4 Battery Specifications

Table 2-6 Battery Specifications

Item	Data
Capacity	12 V, 7.0 Am/H or equivalent (Voltage must be 12 V)
Recommended Battery	GS Yuasa NP7-12 (151 x 65 x 97.5 mm / 2.7 kg) <GS Yuasa International LTD.> The Battery must be UL recognized product.
Number of Batteries (per Box)	2
Backup Duration (Estimated)	1 hour

2.5 Battery Installation

Before floor-mounting or wall-mounting the IP4WW-Battery Box, the batteries must be installed into the IP4WW-Battery Box.

1. Loosen two screws and remove the Front Cover.

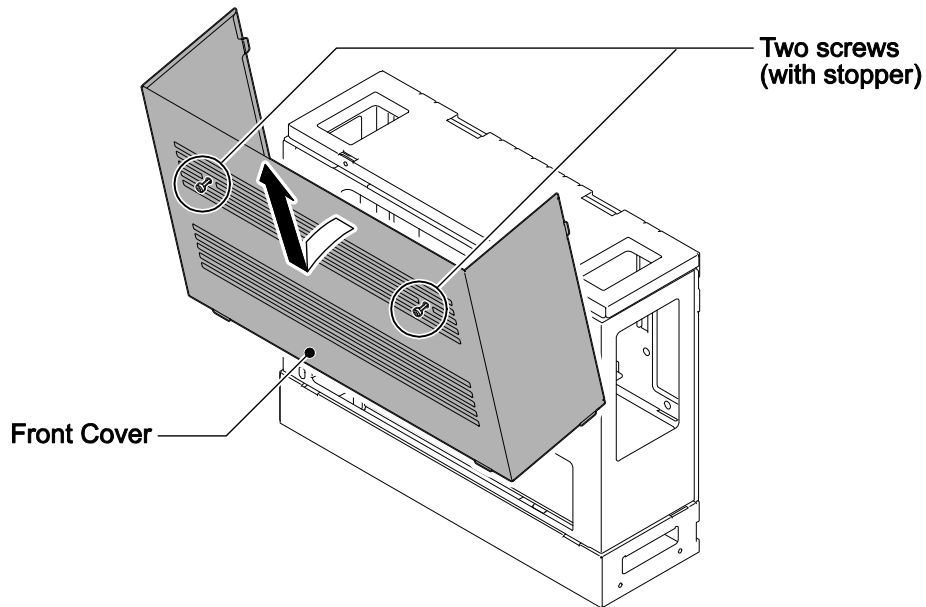

Figure 2-17 Removing the Front Cover

2. Disconnect the Battery Connection Cable from the Fuse Unit if the cable is plugged already.

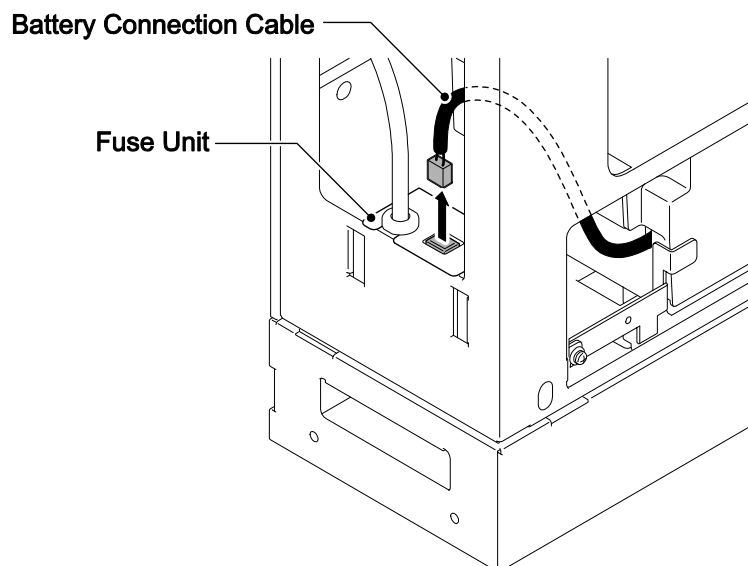

Figure 2-18 Disconnect Battery Connection Cable

3. Loosen the screw and lift the Batt Stopper.

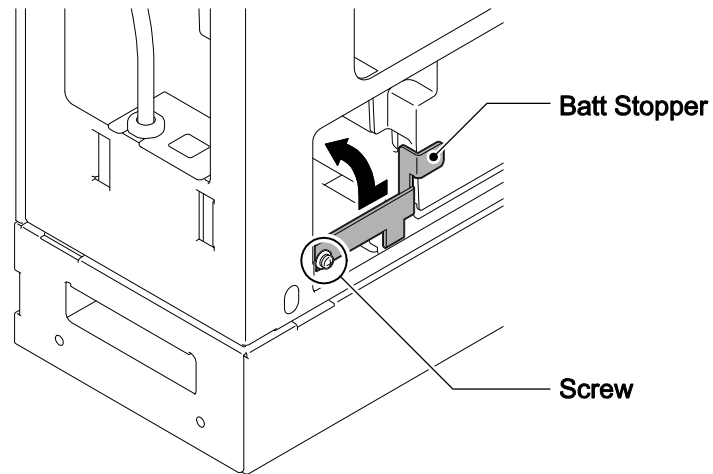

Figure 2-19 Batt Stopper

4. Pull out the Battery tray.

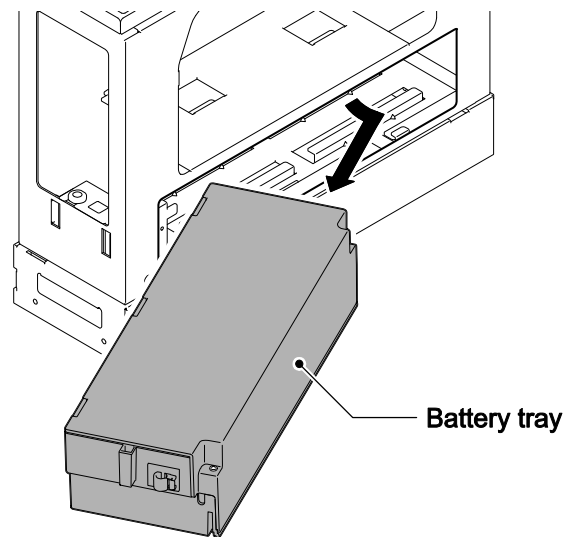

Figure 2-20 Pulling out the Battery Tray

5. Loosen two screws and remove the Battery tray cover.
6. Remove two screws and remove the Battery tray bracket.

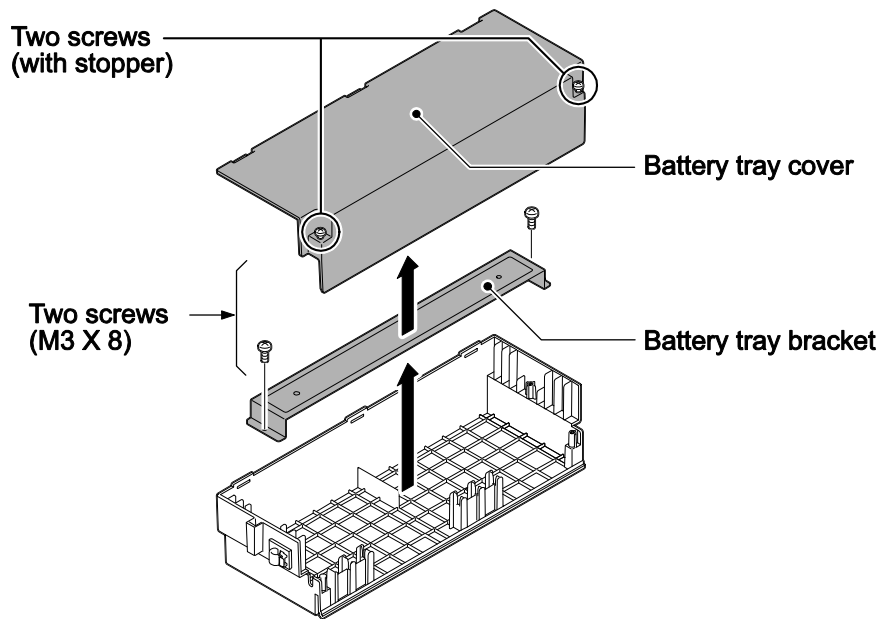

Figure 2-21 Remove the Battery Tray Bracket

7. Install two batteries into the Battery tray.

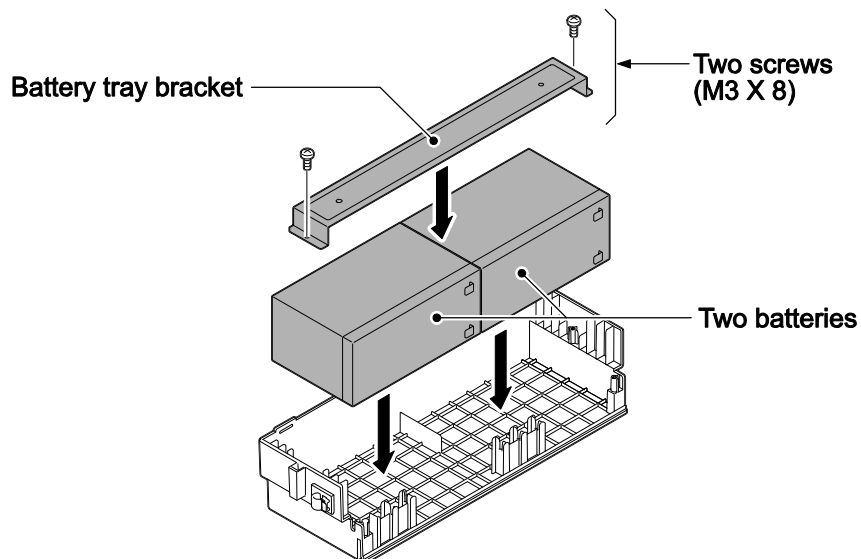

Figure 2-22 Battery Installation

8. Connect the battery cables.

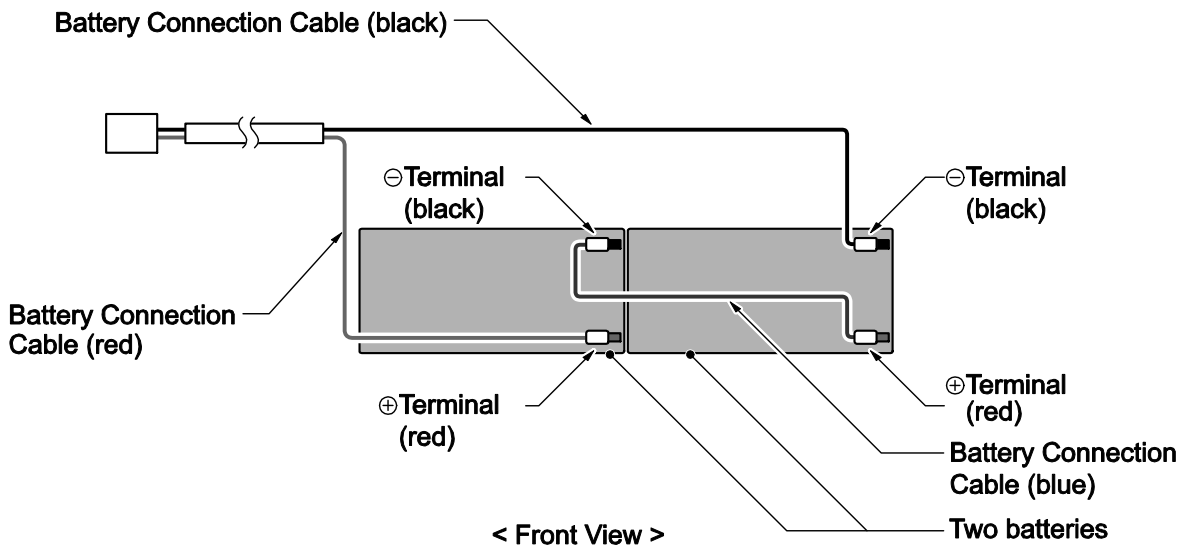

Figure 2-23 Connecting the Battery Cables



Incorrect installation of batteries may damage the Fuse Unit or cause possible fire.

9. Insert Battery Connection Cable into the Cable guides as shown in the next diagram.
10. Install the Battery tray cover aligning the three tabs and tightening the two screws.

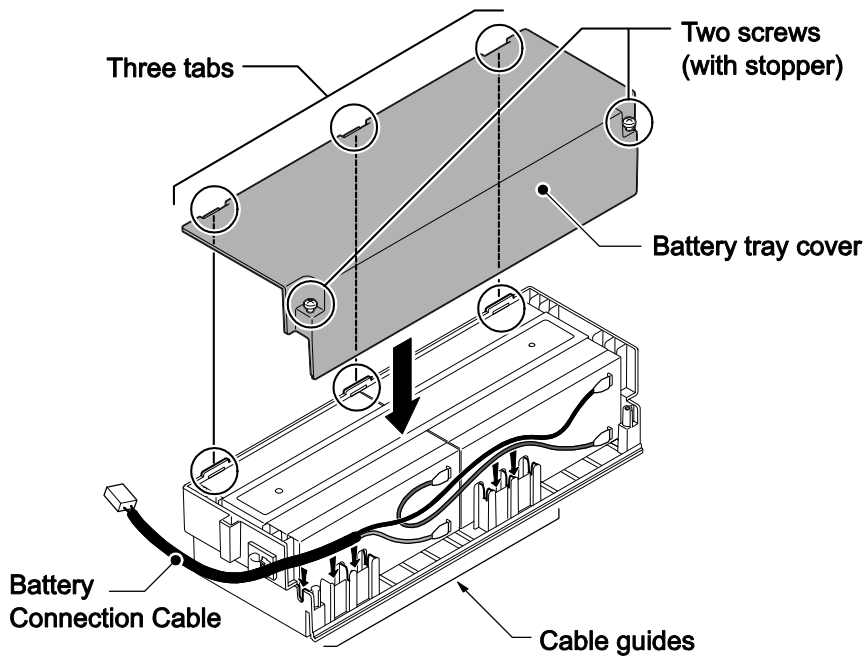

Figure 2-24 Installation of Battery Tray Cover



Do not pull the Battery connection cable strongly.



Be careful not to catch the Battery Connection Cable when installing the Battery tray cover.



Write down the year and month of the next battery replacement in the label on Front cover.

11. Insert the Battery tray into the Battery Box.

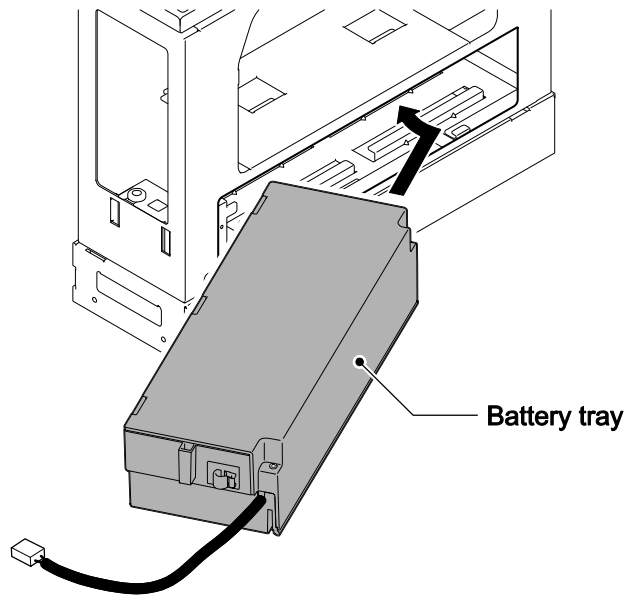

Figure 2-25 Inserting the Battery Tray

12. Set the Batt Stopper bracket in place and secure with screw.

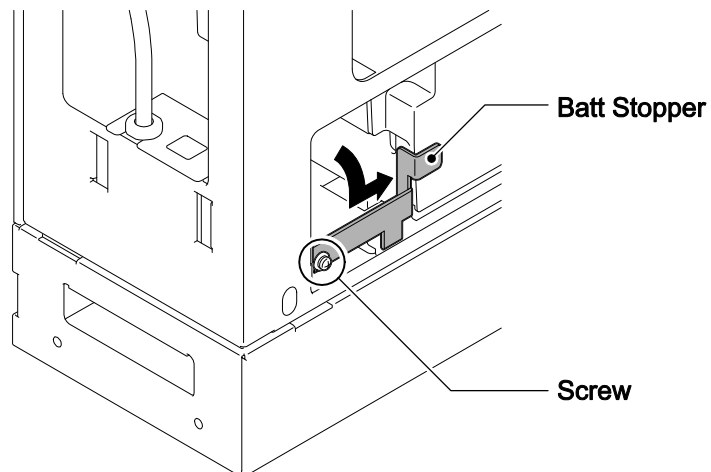

Figure 2-26 Secure Batt Stopper Bracket

13. Plug the Battery Connection Cable into the Fuse unit.

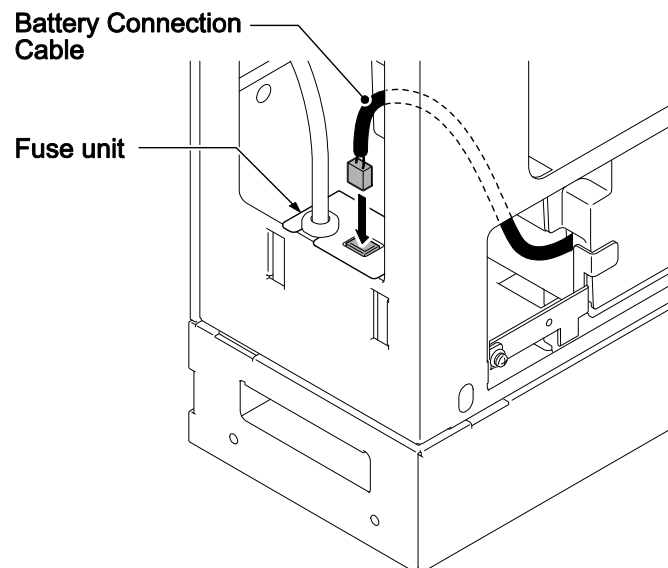

Figure 2-27 Connecting the Battery Connection Cable

- Align tabs a to f to holes A to F on Battery Box. Slide the Front cover and tighten the two screws.

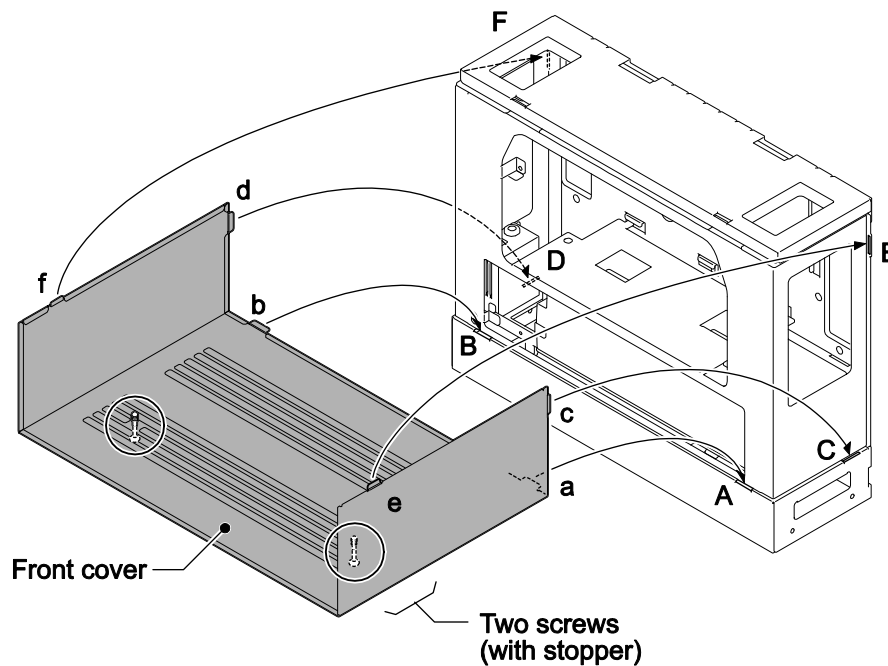

Figure 2-28 Installation of Front Cover

2.6 Mounting the IP4WW-Battery Box

The IP4WW-Battery Box can be installed on either the floor or wall. One KSU can be mounted on an IP4WW-Battery Box.

2.6.1 Floor-Mounting the IP4WW-Battery Box

Battery box can be mounted on the floor using the FM/WM Base-F, FM/WM Base-R and WM Support. (Note: FM = Floor-Mount and WM = Wall-Mount)

- Assemble the FM/WM Base-F, Base-R and WM Support.

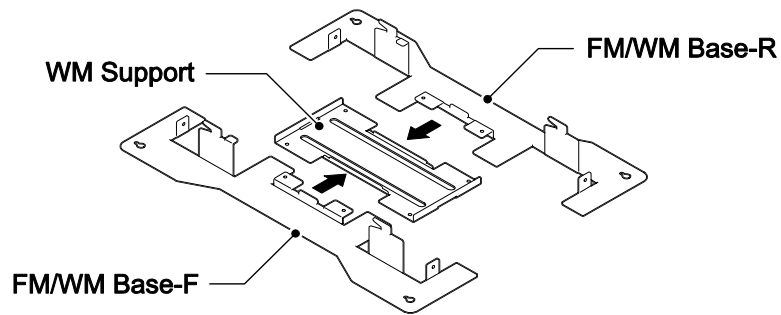

Figure 2-29 Bases and Support of the Battery Box

2. Refer to Floor-Mount Spacing Guide for required spacing before drilling holes for 10 mm (0.394") anchor bolts (locally procured). Mark and drill the four holes required to install the FM/WM Base.
3. Using anchor bolts, secure the FM/WM Base to the floor.

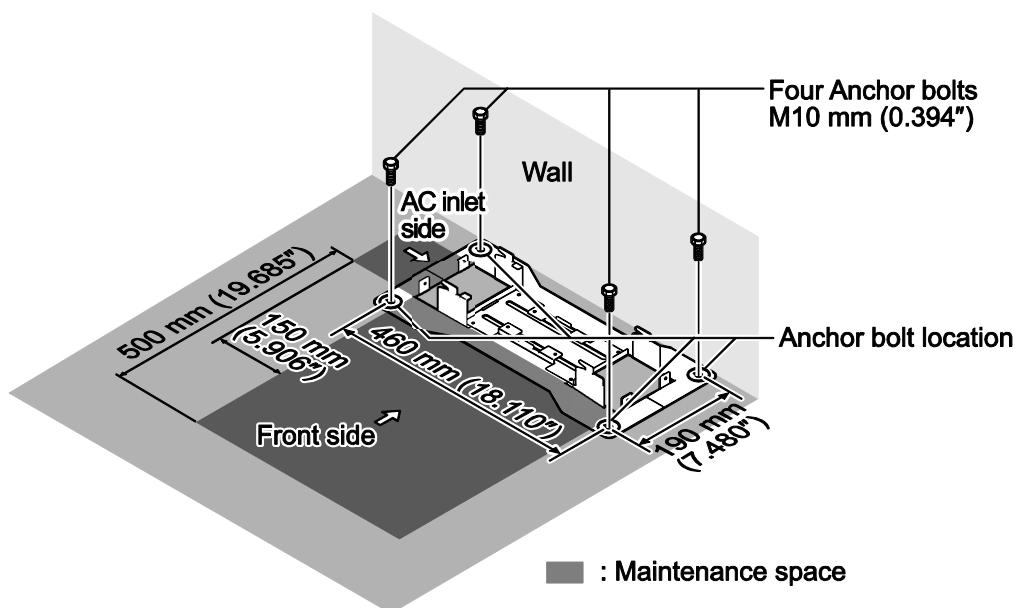

Figure 2-30 Floor-Mount Spacing Guide

4. Using the four hooks on the FM/WM Base mount the IP4WW-Battery Box on the Base.

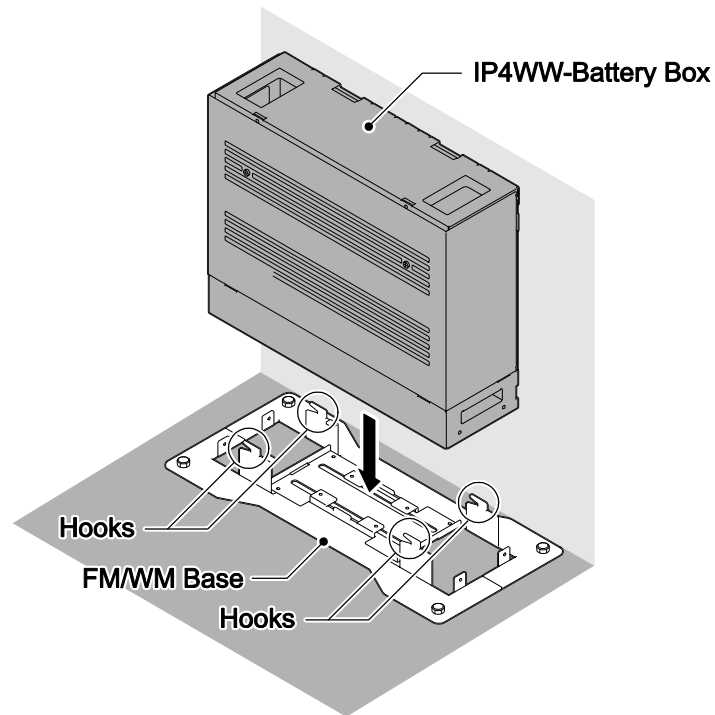

Figure 2-31 Mounting the Battery Box

5. Using four supplied screws, secure the IP4WW-Battery Box to the FM/WM Base.

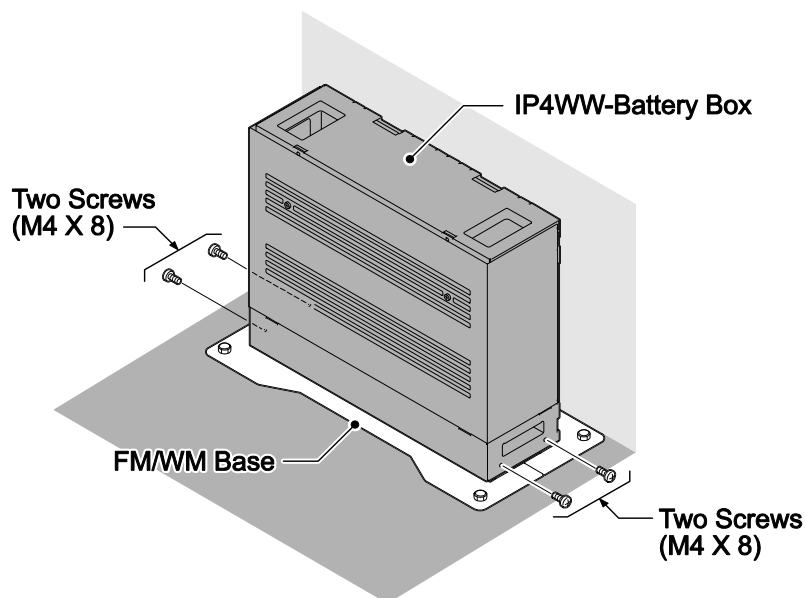

Figure 2-32 Securing the Battery Box

2.6.2 Wall-Mounting the IP4WW-Battery Box



When wall-mounting the IP4WW-Battery Box, ensure the wall can support the weight of the Battery Box (Total weight=17.6 kg (620.75 oz) - Including 2-batteries, cord, KSU, etc). The Battery Box is secured to the wall using the FM/WM BASE. Ensure that enough space is available to allow the installation of additional KSU.



Plywood should first be installed on the wall where the Battery Box will be positioned. This allows secure anchoring of the screws which support the weight of the Battery Box.

1. Using four supplied screws, secure the WM Support to the FM/WM Base-F and Base-R.

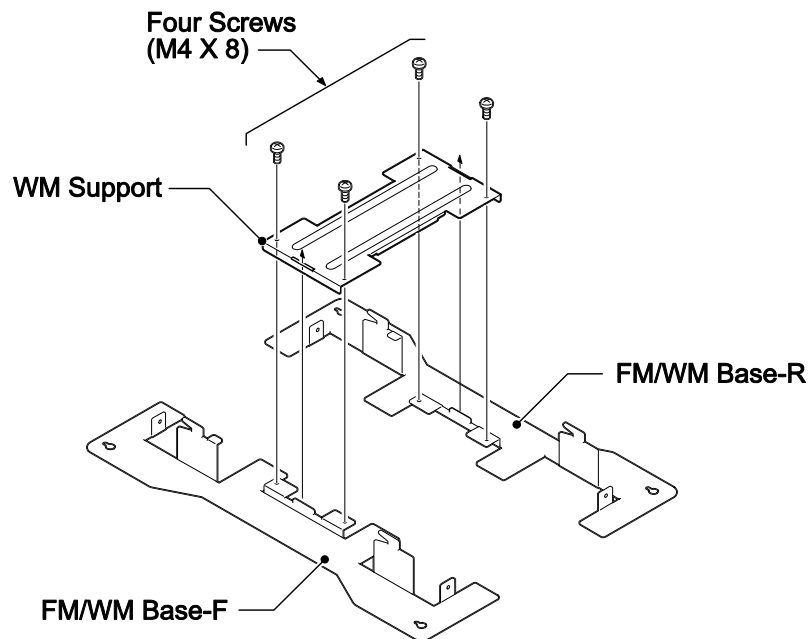

Figure 2-33 Assemble Battery Box Base

2. Refer to Wall-Mount Spacing Guide for required spacing before drilling holes for 10 mm anchor bolts (locally procured).
Mark and drill the four holes required to install the FM/WM Base.
3. Using anchor bolts, secure the FM/WM Base to the wall.

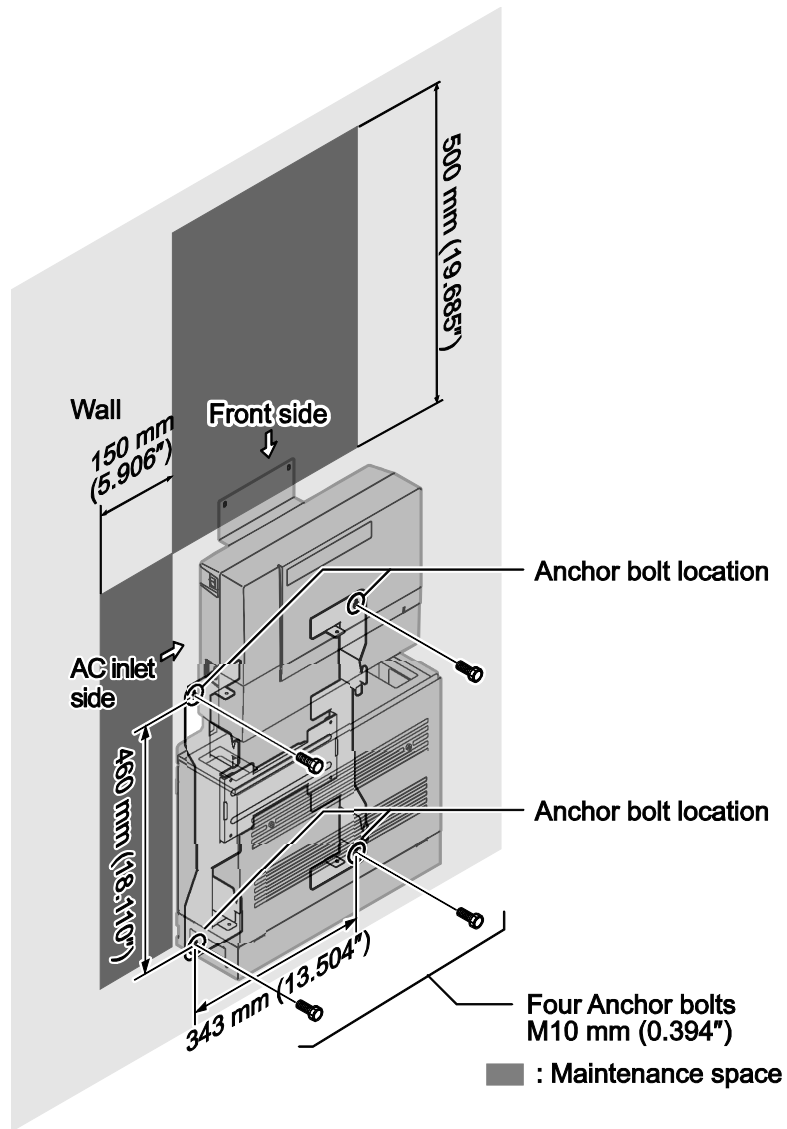

Figure 2-34 Wall-Mount Spacing Guide

4. Loosen two screws and remove the Front Cover.

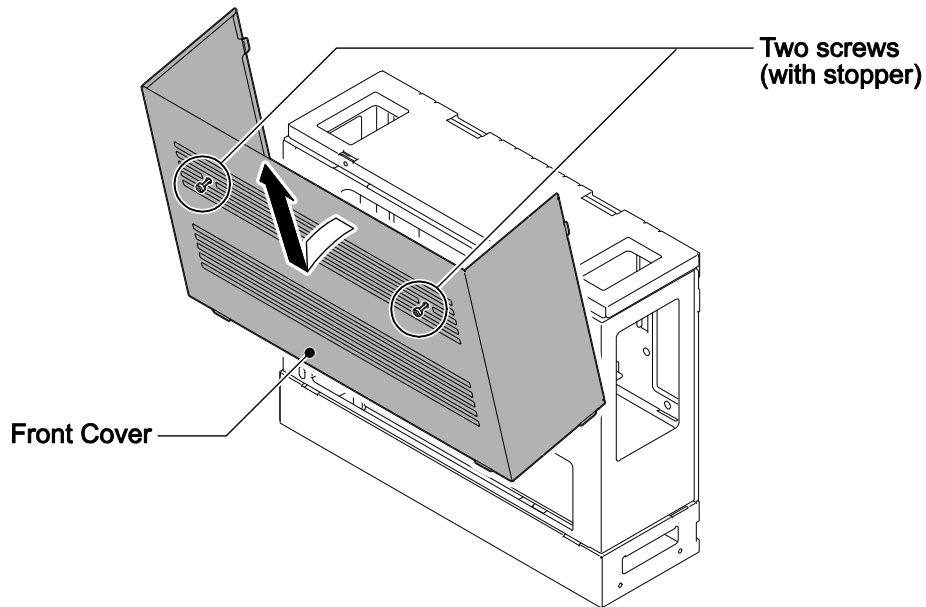

Figure 2-35 Removing the Front Cover

5. Using the four hooks on the FM/WM Base mount the IP4WW-Battery Box to the Base.

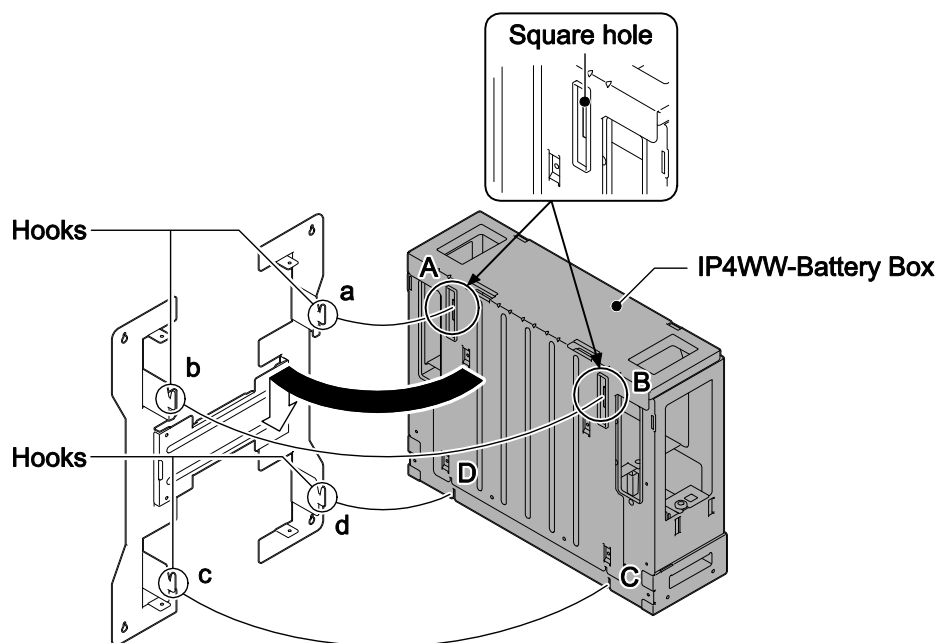

Figure 2-36 Mounting the Battery Box

6. Using one supplied screw (M3x6 with washer), secure the back plane of the Battery Box to the FM/WM Base.

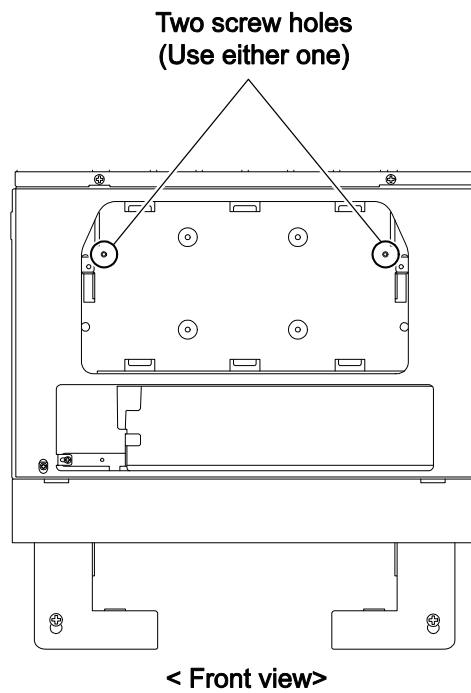

Figure 2-37 Securing the Battery Box

2.6.3 Mounting One KSU on the Battery Box

Before wall-mounting or floor-mounting the IP4WW-Battery Box, a single KSU can be mounted on the Battery Box.

1. Loosen two screws and remove the Front Cover of the Battery Box.

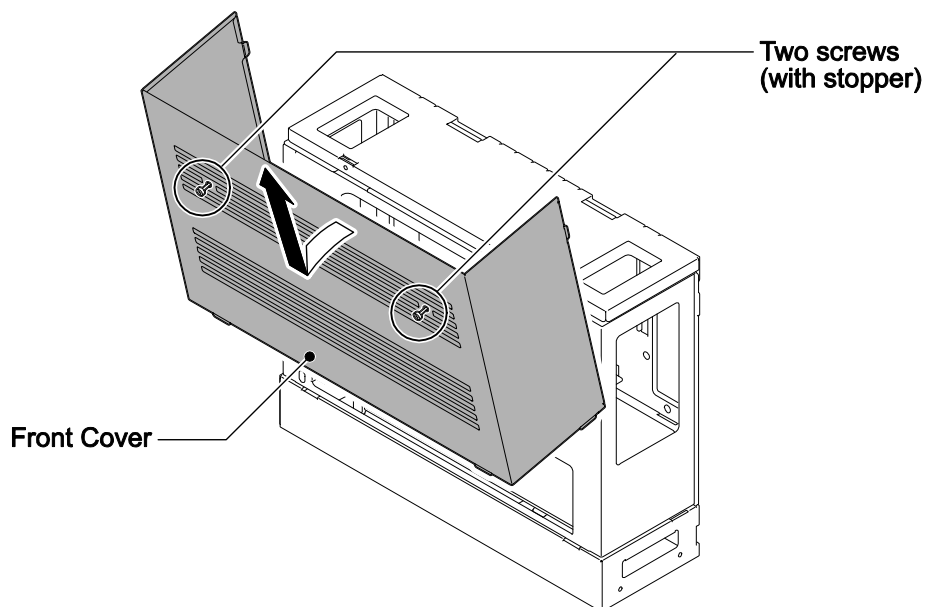

Figure 2-38 Removing the Front Cover

2. Loosen two screws and remove the L-Bracket.

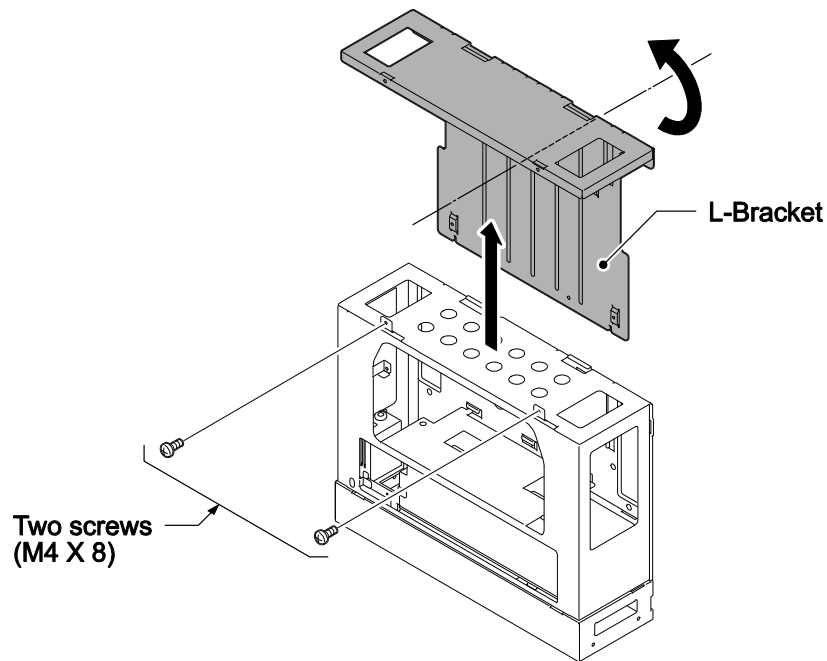

Figure 2-39 Removing the L-Bracket

3. Turn the L-Bracket upside down.
Rotate the L-Bracket 180 degrees so that the upper FACE as shown in Removing the L-Bracket is located at the bottom as shown in Securing the L-Bracket and WM Hook.
4. Insert tabs on Battery Box into holes on L-Bracket.
Secure the L-Bracket to the Battery Box using two screws.
5. Using two screws (M4x8), secure the WM Hook to the L-Bracket.
6. Using two anchor bolts (locally procured), secure the WM Hook to the wall.



The WM Hook is required for securing both Floor-mount and Wall-mount cases.

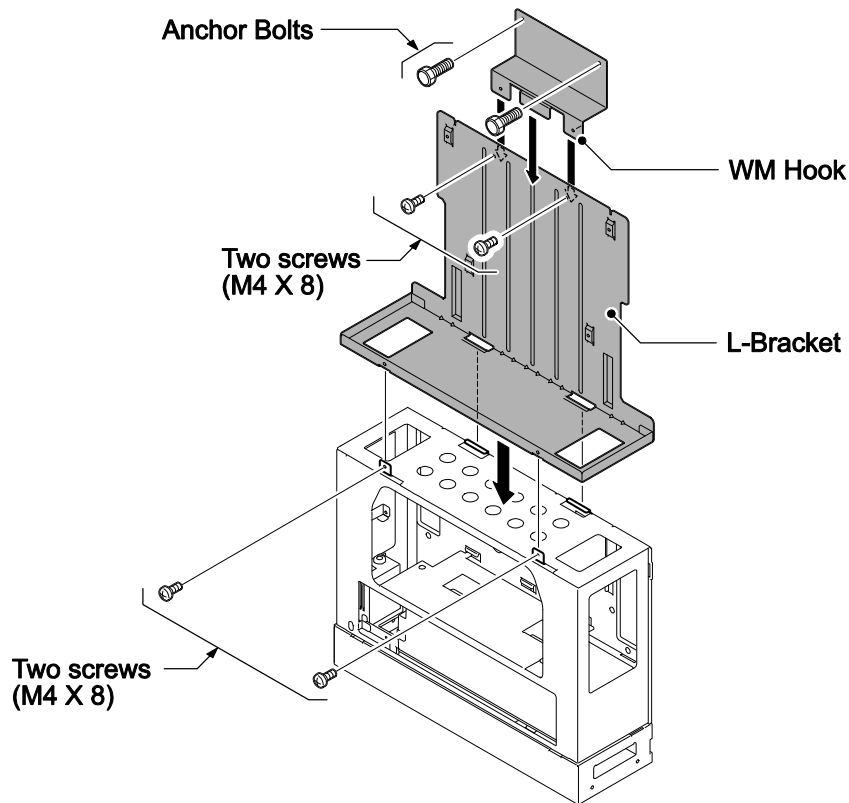

Figure 2-40 Securing the L-Bracket and WM Hook

7. Install four screws into the L-Bracket (Do not tighten). A space of 2.5 mm (0.098") to 3.5 mm (0.138") for KSU mounting is required. Mount the KSU on the screw heads.

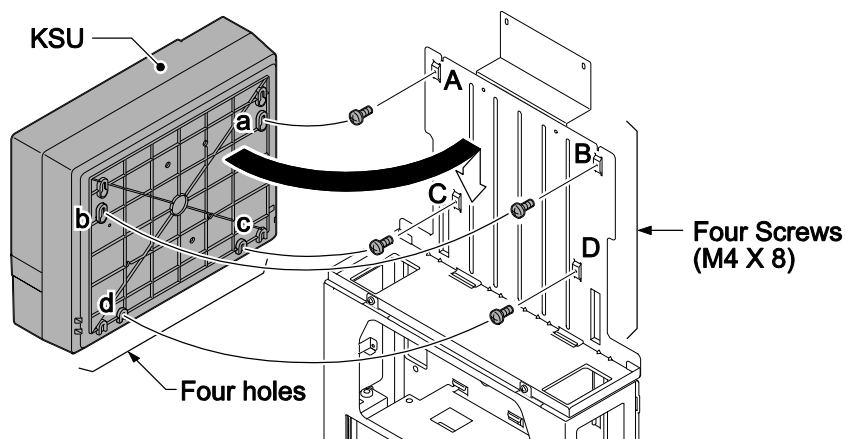

Figure 2-41 Attaching the KSU

8. Hold open the Sub-Cover of the KSU, and fasten two screws to mount the KSU.

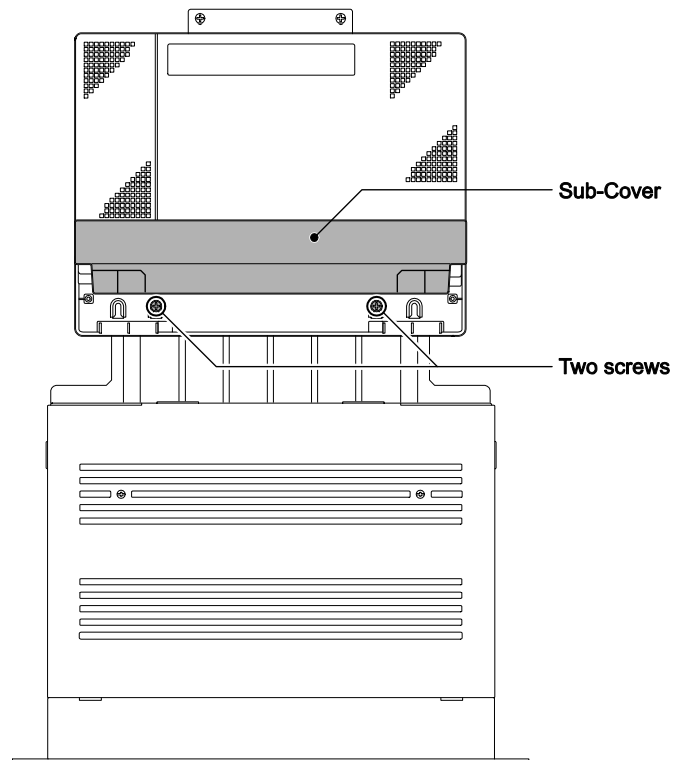

Figure 2-42 KSU Mounting on Battery Box

2.7 IP4WW-Battery Box to KSU Connection



Do not connect the DX2E-32i/NX7E Topaz Battery Box to the SL1100 system. Damage to equipment or property may result.



Make sure the system power is off.

1. Power off the KSU and disconnect AC cord.
2. Open the Sub-Cover of the KSU.

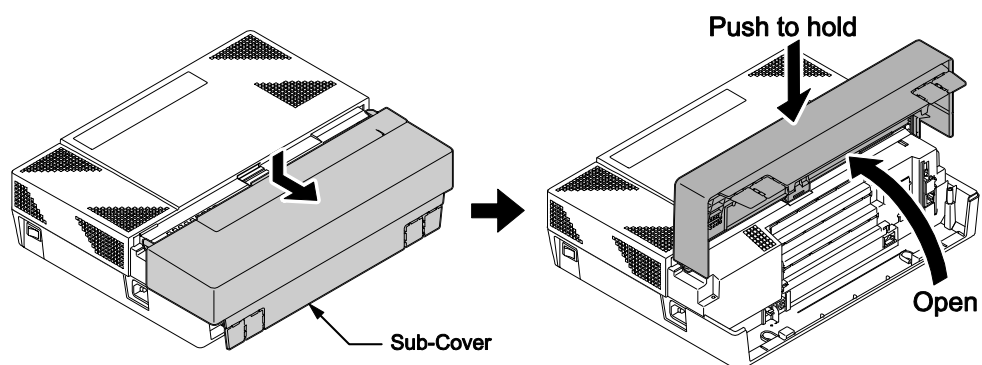

Figure 2-43 Sub-Cover Open and Hold

3. Cut and remove Plastic Knockout from the Sub-Cover to connect Battery cable.

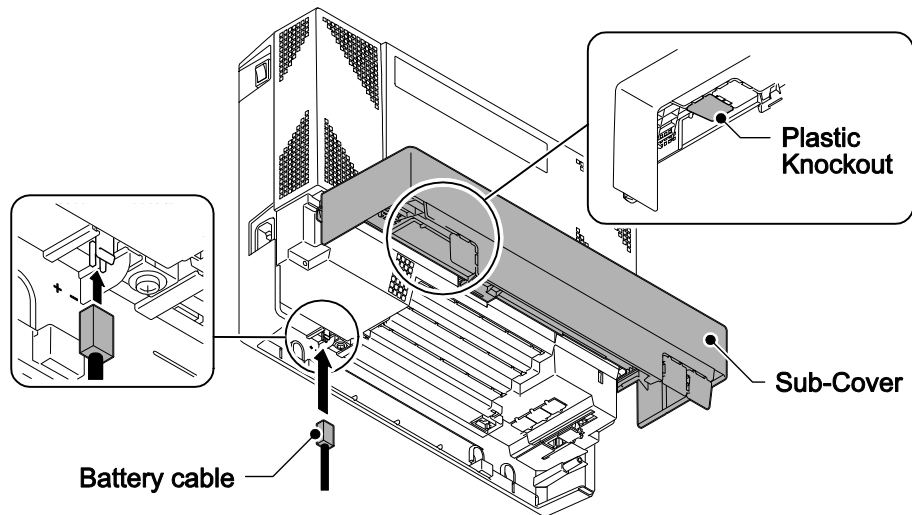

Figure 2-44 Connecting Battery Cable

4. Connect Battery cable from the Battery box to Battery connector on the KSU.

2.8 IP4WW-Battery Box Fuse Replacement



In the event of a blown fuse correct the fault causing the fuse to blow before replacing the fuse; otherwise you may cause fire or electrical hazards.



Be sure to use only the specified fuse (250VT8AL).



Be sure to install the fuse into the correct location.



Be careful not to burn yourself on the heated fuse. The blown fuse may be heated soon after blowing.

1. Power off the KSU and disconnect AC cord.
2. Loosen two screws and remove the Front Cover.

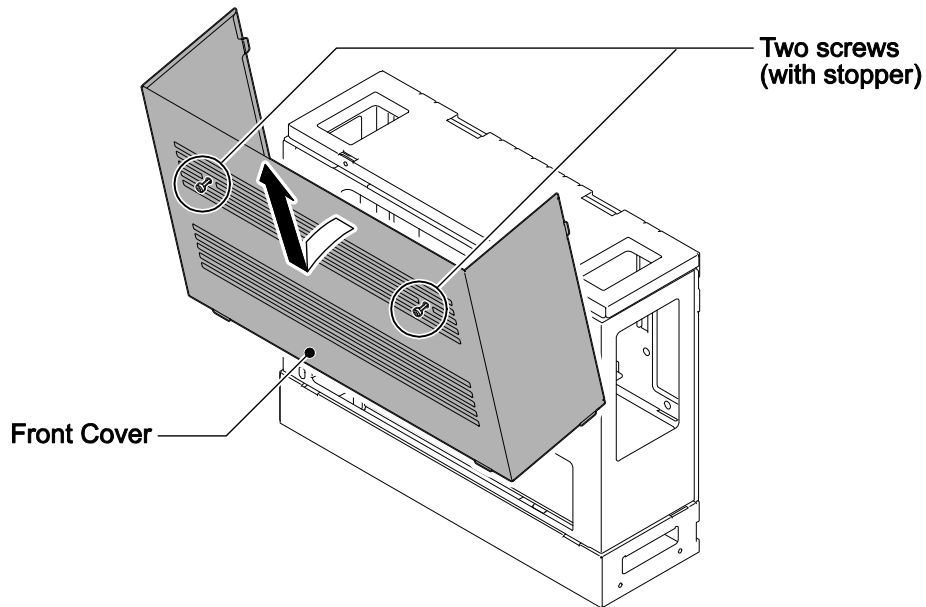

Figure 2-45 Removing the Front Cover

3. Disconnect the Battery connection cable from the Fuse Unit.

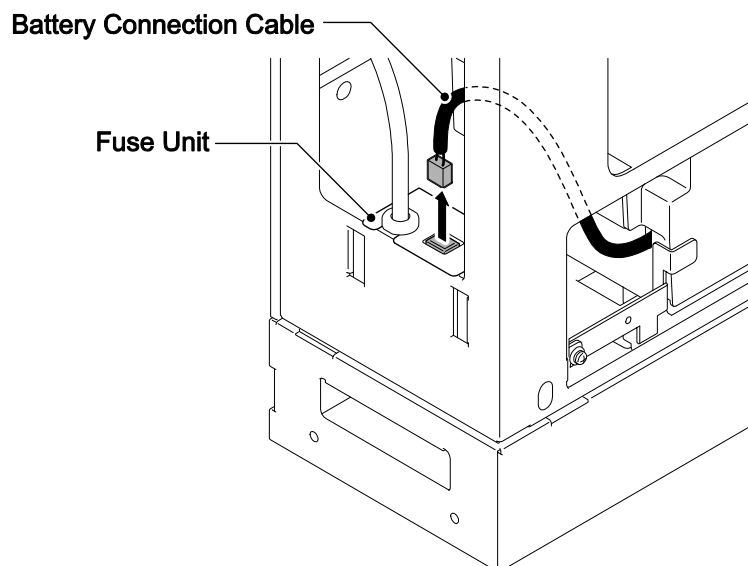

Figure 2-46 Disconnecting the Battery Connection Cable

4. Loosen the screw from the Fuse Unit.

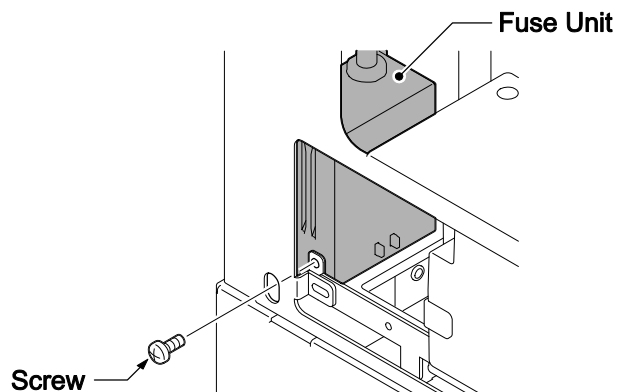

Figure 2-47 Loosen the Fuse Unit Screw

5. Slide Fuse Unit out of the Battery box.
6. Replace the fuse (250VT8AL).

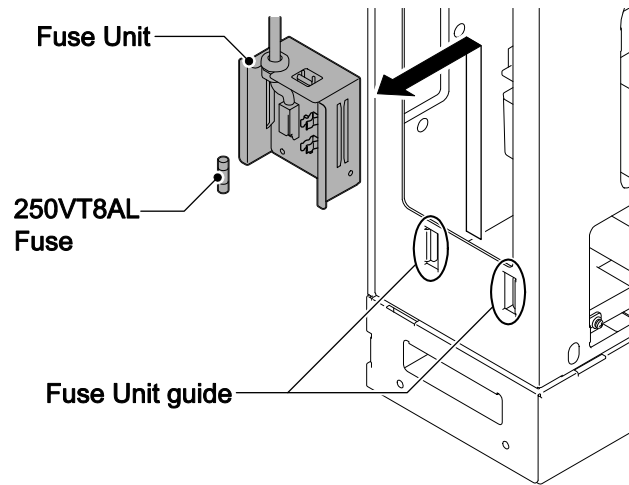

Figure 2-48 Replacing the Fuse

7. Using the Fuse Unit guides, slide the Fuse Unit into the Battery Box.

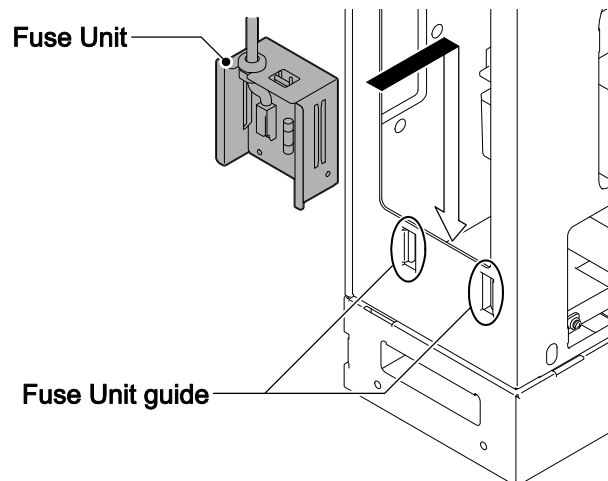

Figure 2-49 Install the Fuse Unit

8. Secure the Fuse Unit by tightening the screw.

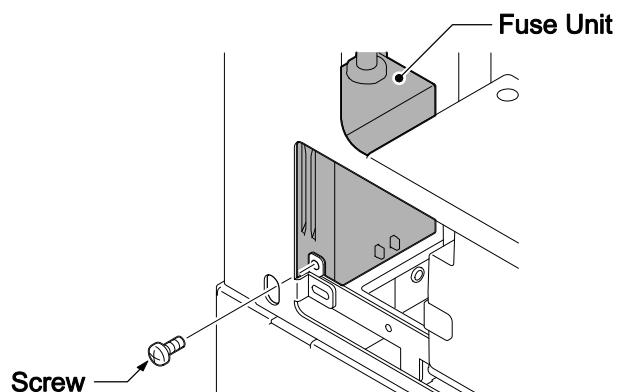

Figure 2-50 Securing the Fuse Unit

9. Reconnect the Battery Connection Cable to the Fuse Unit.

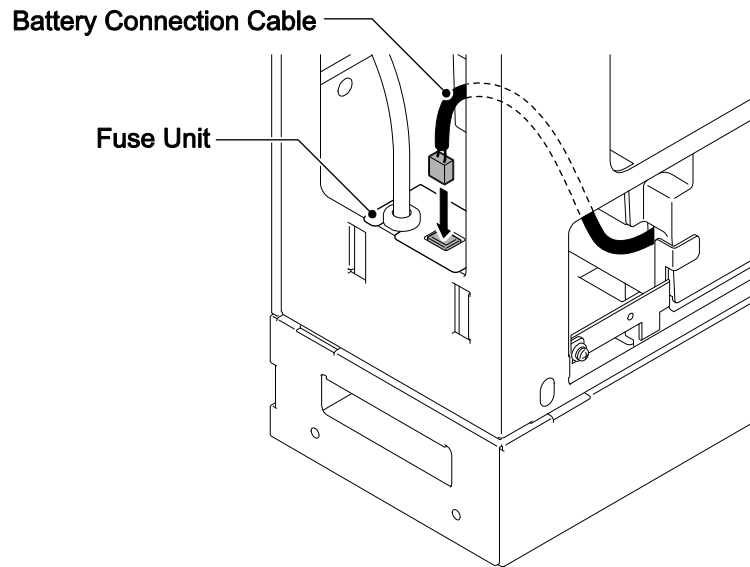

Figure 2-51 Connect Battery Connection Cable

10. Align tabs a to f to holes A to F on Battery Box. Slide the Front Cover into position and tighten the two screws.

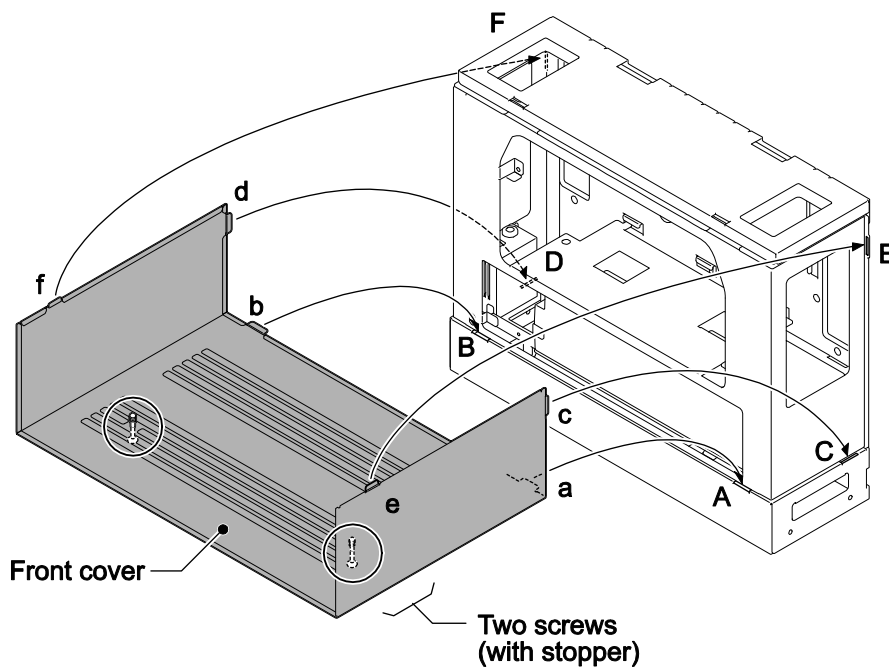

Figure 2-52 Installation of the Front Cover

SECTION 3 INSTALLING THE EXPANSION INTERFACE CARDS

3.1 General

Up to two expansion interface cards can be installed per KSU.

Table 2-7 Expansion Cards

Expansion Interface Card	Description	Note
IP4WW-080E-B1	8 digital extensions card	
IP4[]-008E-B1	8 analogue extensions card	
IP4WW-000E-B1	0 trunk/extension card for ISDN BRI or Analogue Trunk	
IP4WW-4COIDB-B1	4 analogue trunk daughter board (Mount on the 084M-B1/080E-B1/008E-B1/000E-B1)	
IP4WW-2BRIDB-C1	2 Euro-ISDN BRI daughter board (Mount on the 084M-B1/080E-B1/008E-B1/000E-B1)	
IP4WW-1PRIU-C1	1 ISDN PRI card	



The function of IP4WW-000E-B1 card is just a mounting card for the 4COIDB or 2BRIDB.

The 4COIDB-B1 and 2BRIDB-C1 can be installed in following combinations;

Daughter Board	Option Unit			
	084M-B1	080E-B1	008E-B1	000E-B1
4COIDB-B1	Yes	Yes	Yes	Yes
2BRIDB-C1	Yes	Yes	Yes	Yes

3.2 Unpacking

Unpack the 080E-B1/008E-B1/000E-B1/4COIDB-B1/2BRIDB-C1/1PRIU-C1 and check it against the following list. Inspect for physical damage.

Table 2-8 Expansion Card Packing List

Items	List of Contents	QTY	Note
IP4WW-080E-B1	080E-B1 PCB (with PKG Spacer)	1	
	Nylon Spacers	2	
	Metal Spacers	2	
	Screws (with circular washer)	2	
IP4[]-008E-B1	008E-B1 PCB (with PKG Spacer)	1	
	Nylon Spacers	2	
	Metal Spacers	2	
	Screws (with circular washer)	2	
IP4WW-4COIDB-B1	4COIDB-B1 PCB	1	
	Nylon Spacers	2	
	4COIDB Label	1	
	Metal Spacers	1	
	Screws (with circular washer)	2	
IP4WW-000E-B1	000E-B1 PCB (with PKG Spacer)	1	
	Nylon Spacers	2	
	Metal Spacers	2	
	Screws (with circular washer)	2	
IP4WW-2BRIDB-C1	2BRIDB-C1 PCB	1	
	Nylon Spacers	2	
	2BRI Label	1	
	Metal Spacers	1	
	Screws (with circular washer)	2	
IP4WW-1PRIU-C1	1PRIU-C1 PCB (with PKG Spacer)	1	
	Nylon Spacers	2	
	Metal Spacers	2	
	Screws (with circular washer)	2	

3.3 Mounting the Expansion Interface Card



DO NOT POWER ON until all installation has been completed.

Fit the optional 4COIDB-B1/2BRIDB-C1 daughter boards before installing the 084M-B1/080E-B1/008E-B1/000E-B1 PCBs.

Set the switches on the 2BRIDB-C1 board before mounting it onto the 084M-B1/080E-B1/008E-B1/000E-B1 PCB.

3.3.1 Mounting the 080E-B1/008E-B1/000E-B1 /1PRIU-C1 PCBs

The procedure for mounting the expansion interface cards is as follows;



Do Not Power on until all installation have been completed.

1. Turn off the system power and disconnect the AC cord from KSU.
2. Open and remove the Sub-Cover.

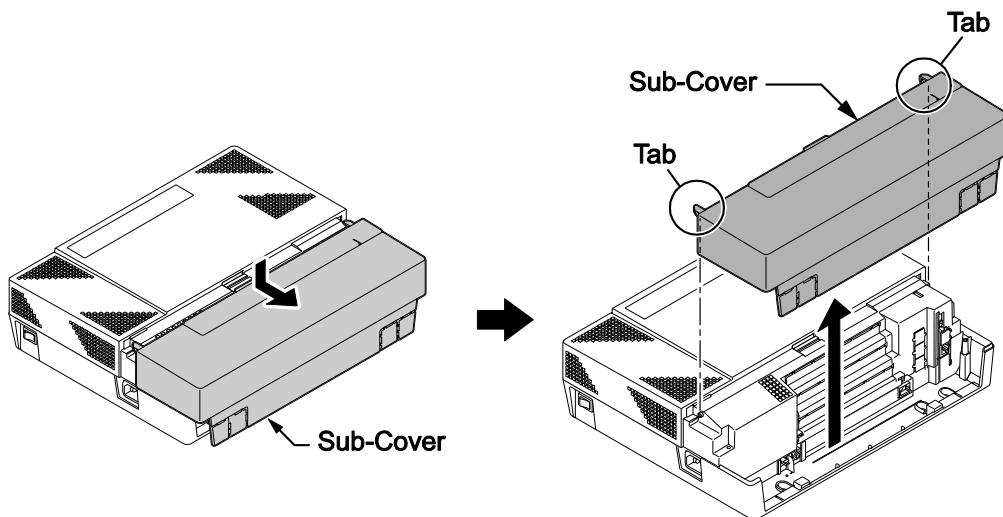

Figure 2-53 Removing the Sub-Cover

3. Loosen two screws and remove the Main-Cover.

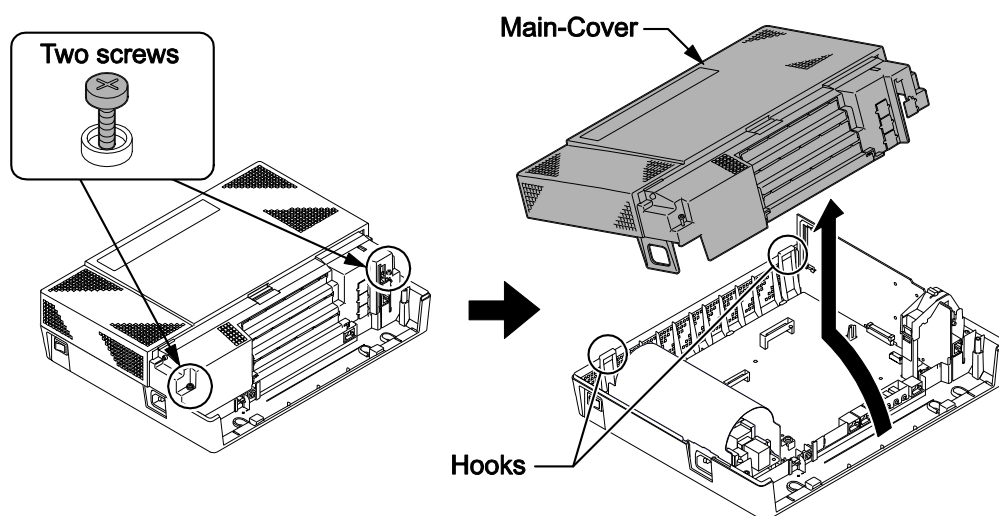

Figure 2-54 Removing the Main-Cover

4. Insert two Nylon-spacers into the specified holes, and fasten two Metal-spacers into the specified holes. (Both Nylon and Metal spacers are provided with 080E/008E/000E/1PRIU)
If no more Expansion Interface cards are to be mounted on the 1st PCB, fasten two screws to secure the 1st PCB on the top of the 080E/008E/000E/1PRIU.

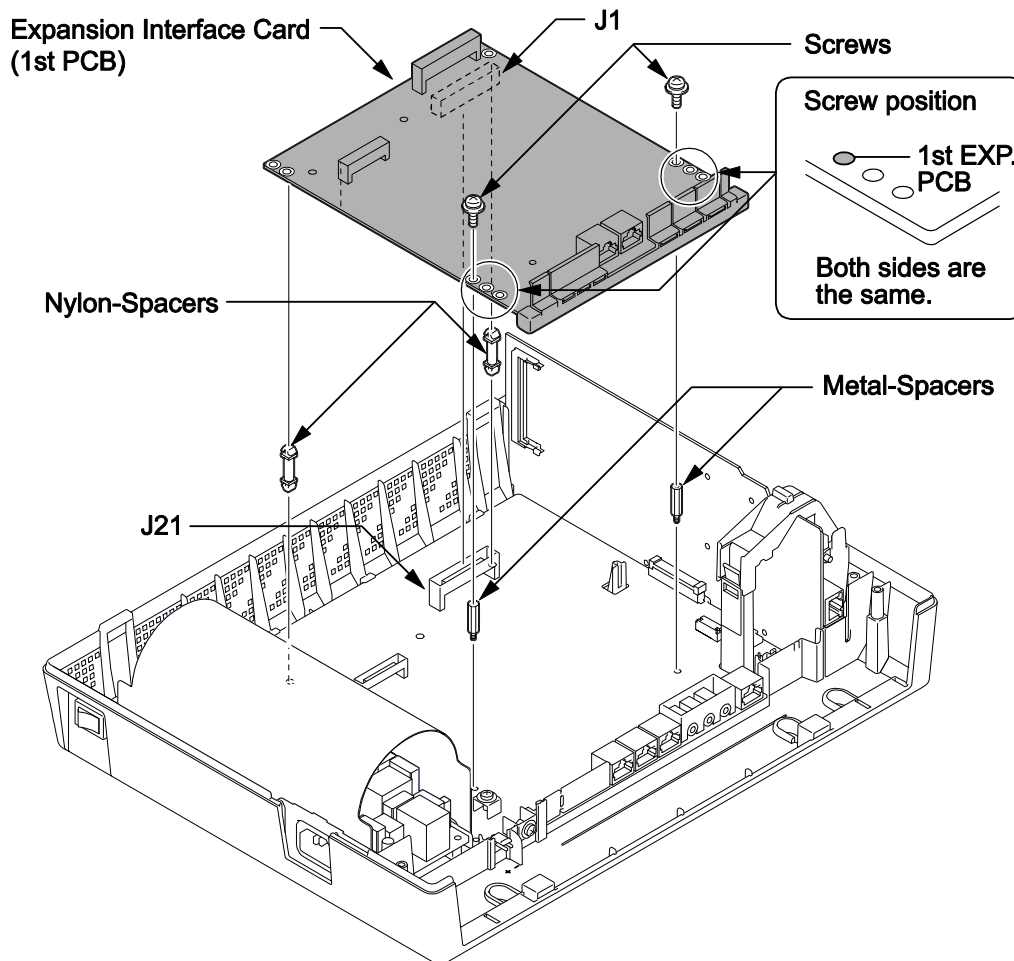

Figure 2-55 Mounting the 1st Expansion Interface Card

5. In case a 2nd PCB is mounted, insert two Nylon-spacers into the specified holes, and fasten two Metal-spacers into the specified holes. (Both Nylon and Metal spacers are provided with 080E/008E/000E/1PRIU)
Fasten two screws to secure the 2nd PCB to the top of the 080E/008E/000E/1PRIU.

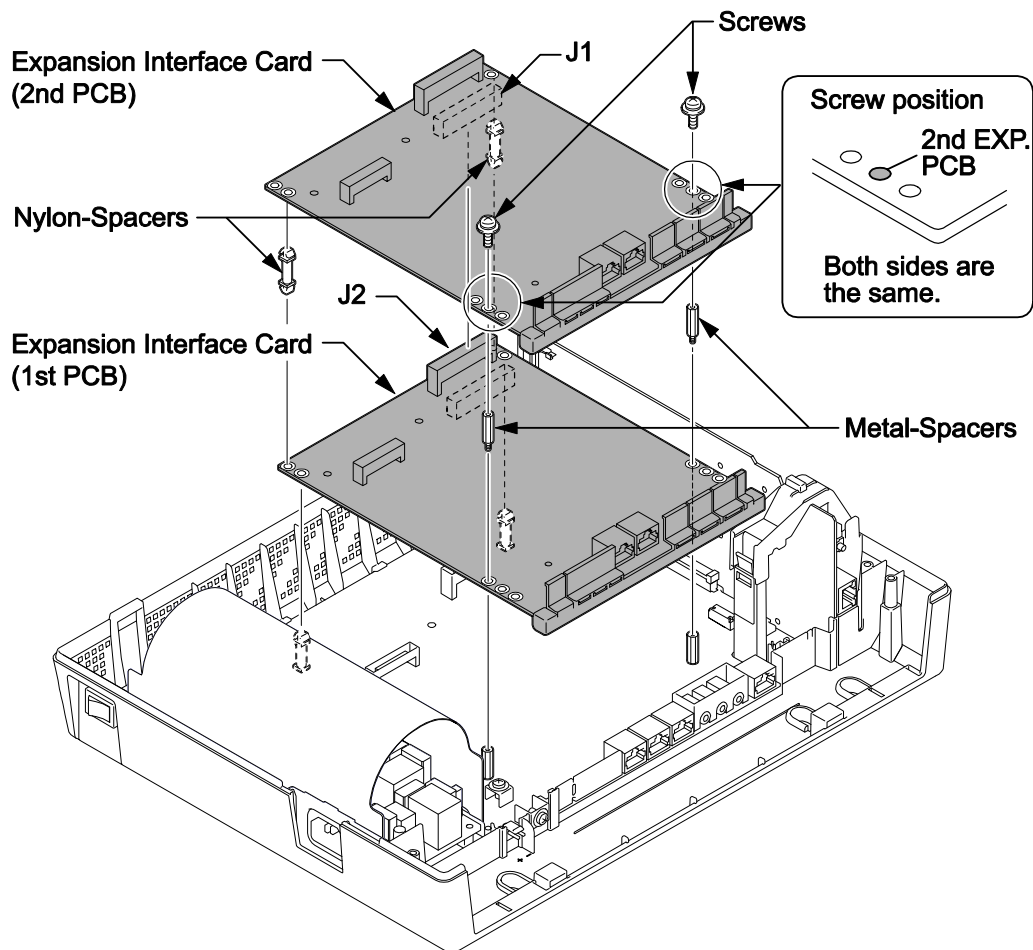

Figure 2-56 Mounting the 2nd Expansion Interface Card

6. Following illustration shows an example for installing two expansion PCBs onto the KSU.

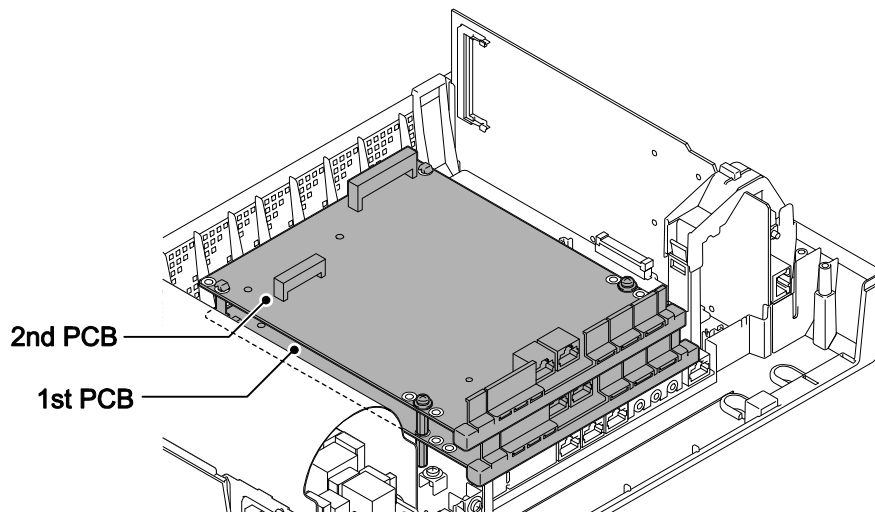

Figure 2-57 Mounting Two Expansion Interface Cards

7. Cut and remove the Plastic Knockouts as required for each Expansion interface card.

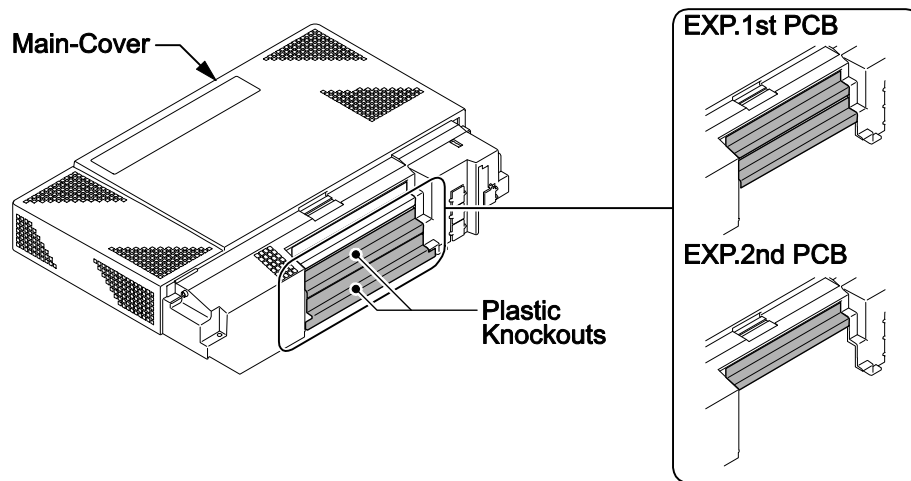

Figure 2-58 Plastic Knockouts

8. Replace the Main-Cover and fasten two screws.

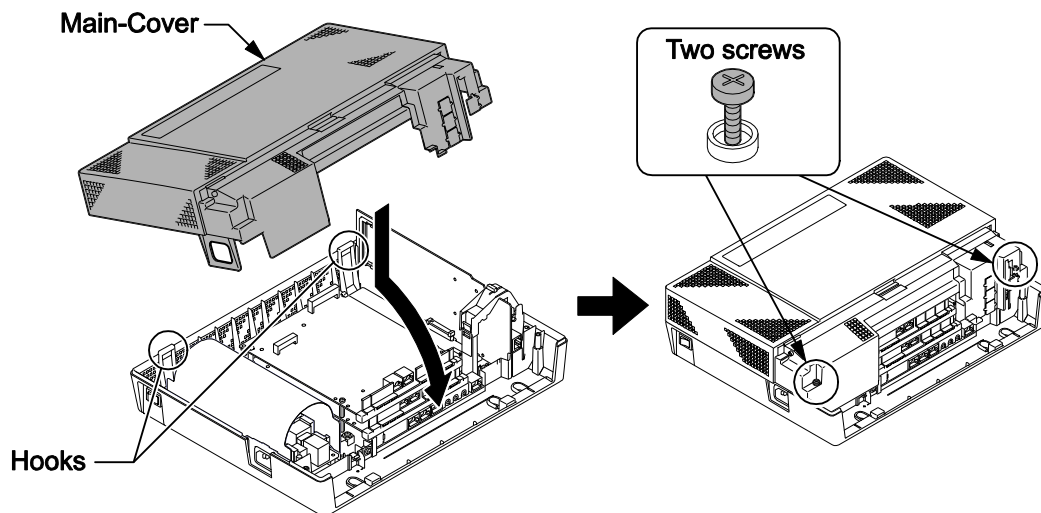

Figure 2-59 Replacing the Main-Cover

3.3.2 Mounting the 4COIDB PCB

1. Cut and remove specified Plastic Knockouts on the 084M-B1/080E-B1/008E-B1/000E-B1 PCB.

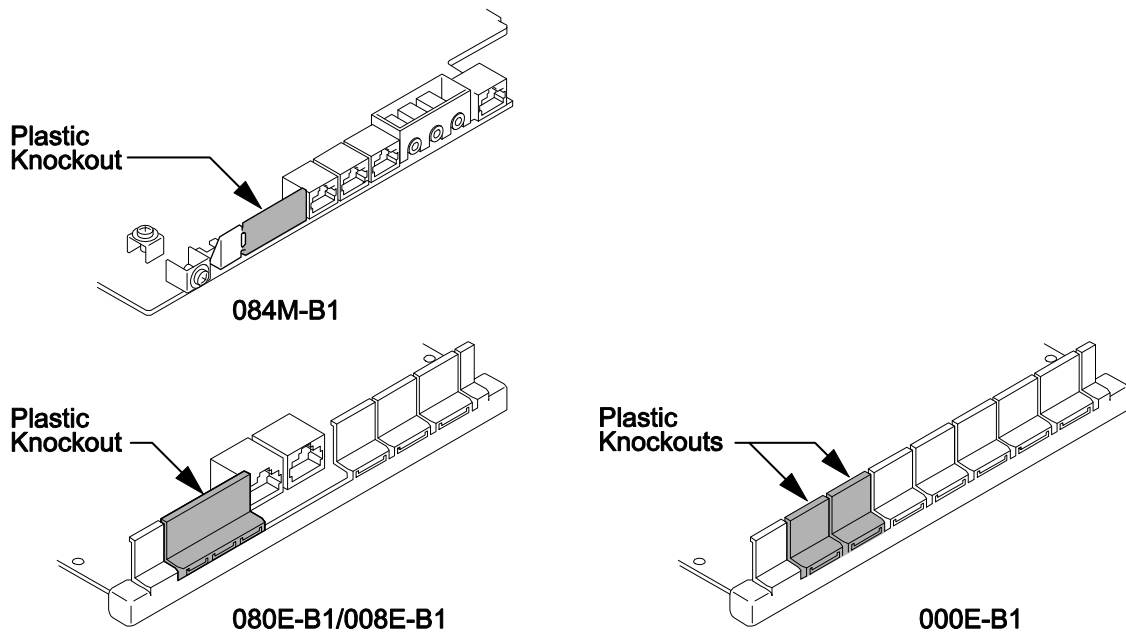

Figure 2-60 Plastic Knockouts on 084M-B1/080E-B1/008E-B1/000E-B1

2. Insert two Nylon-spacers into the specified holes. Using supplied screw, fasten Metal Spacer to 4COIDB-B1 PCB.
3. Mount the 4COIDB-B1 PCB onto the 084M-B1/080E-B1/008E-B1/000E-B1 PCB using two Nylon-spacers and one screw. (Refer to Installing the 4COIDB-B1)
4. Attach the 4COIDB Label to the specified position on the 084M-B1/080E-B1/008E-B1/000E-B1 PCB.

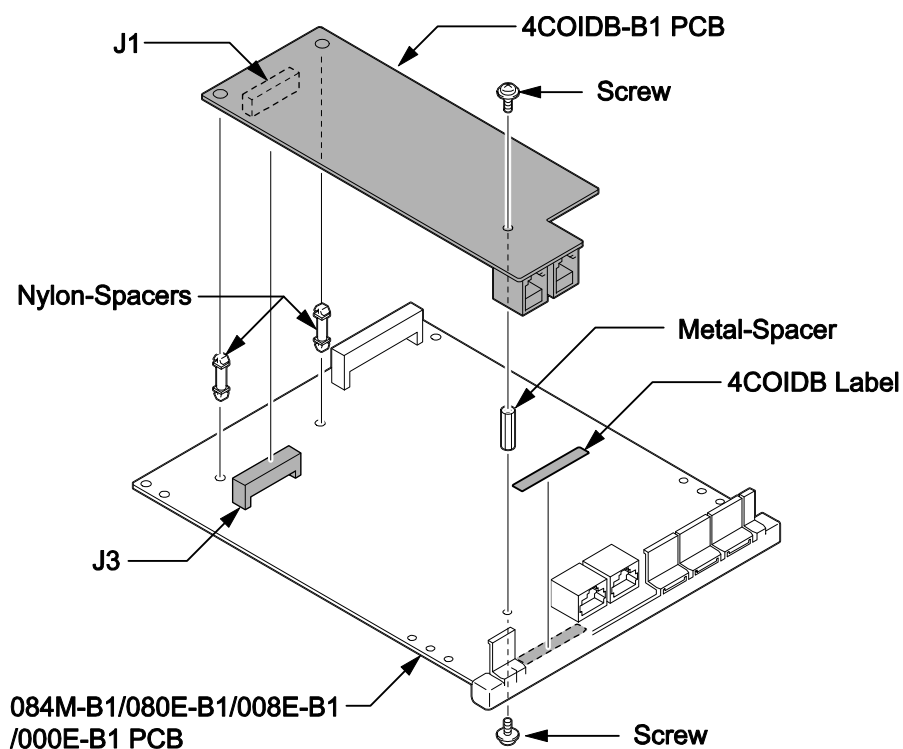

Figure 2-61 Installing the 4COIDB-B1



The 4COIDB-B1 cannot be mounted on the 1PRIU-C1 PCB.

5. Mount the 4COIDB-B1 with 084M-B1/080E-B1/008E-B1/000E-B1 PCB into the KSU.

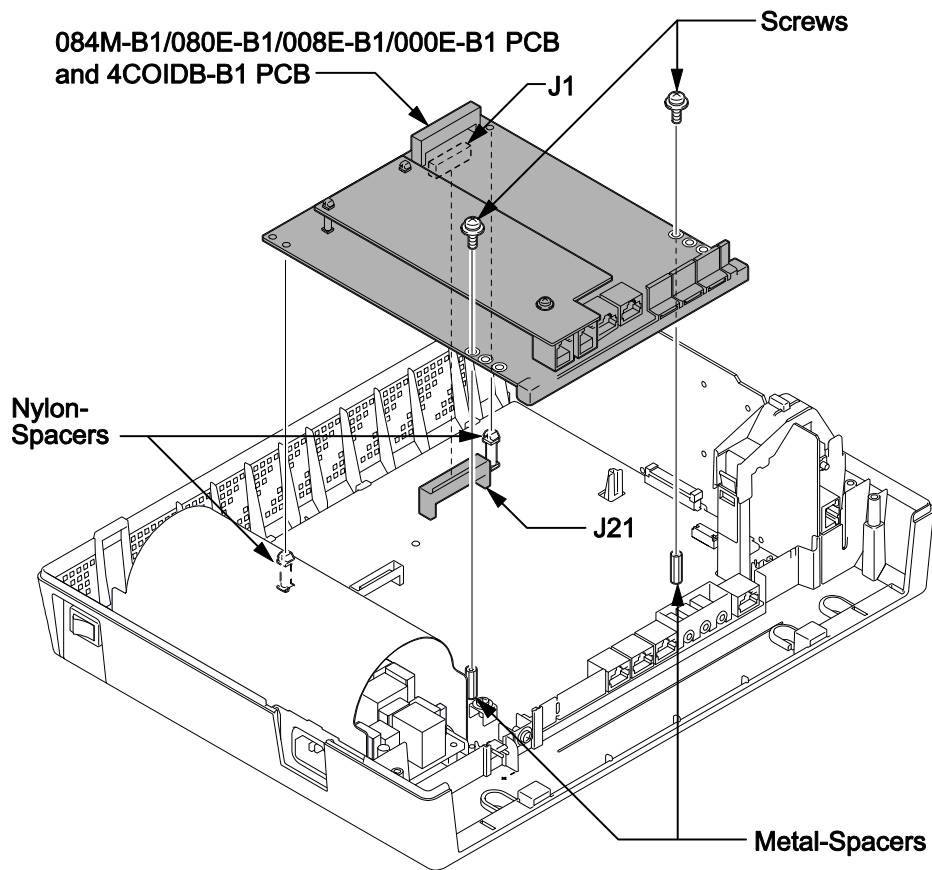

Figure 2-62 Mounting the 4COIDB-B1 into the KSU

6. Replace the Main-Cover and fasten two screws.

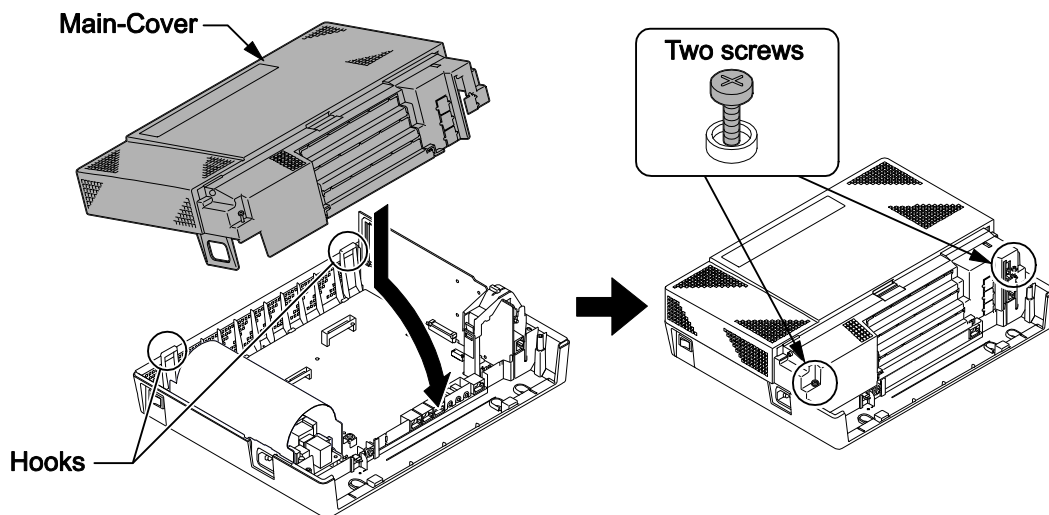

Figure 2-63 Replacing the Main-Cover

3.3.3 Mounting the 2BRIDB PCB



Set the switches on the 2BRIDB-C1 PCB before mounting onto the 084M-B1/080E-B1/008E-B1/000E-B1 PCB, refer to the Switch Setting.

1. Cut and remove specified Plastic Knockouts on the 084M-B1/080E-B1/008E-B1/000E-B1 PCB.

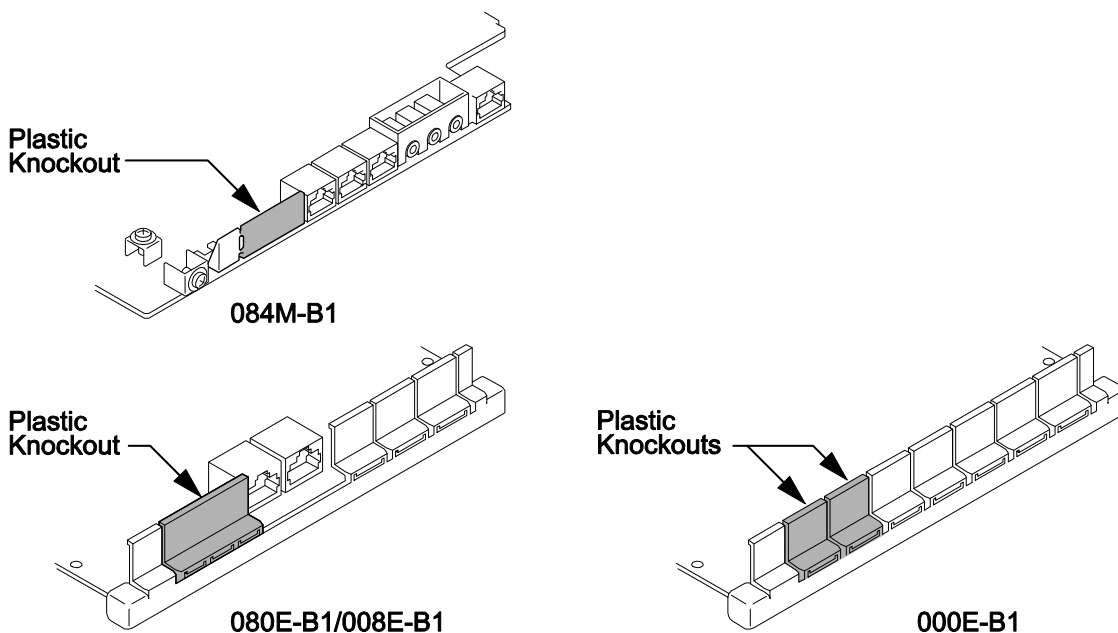

Figure 2-64 Plastic Knockouts on 084M-B1/080E-B1/008E-B1/000E-B1

2. Insert two Nylon-spacers into the specified holes. Using supplied screw, fasten Metal Spacer to 2BRIDB-C1 PCB.
3. Mount the 2BRIDB-C1 PCB onto the 084M-B1/080E-B1/008E-B1/000E-B1 PCB using two Nylon-spacers and one screw. (Refer to Installing the 2BRIDB-C1)
4. Attach the 2BRI Label to the specified position on the 084M-B1/080E-B1/008E-B1/000E-B1 PCB.

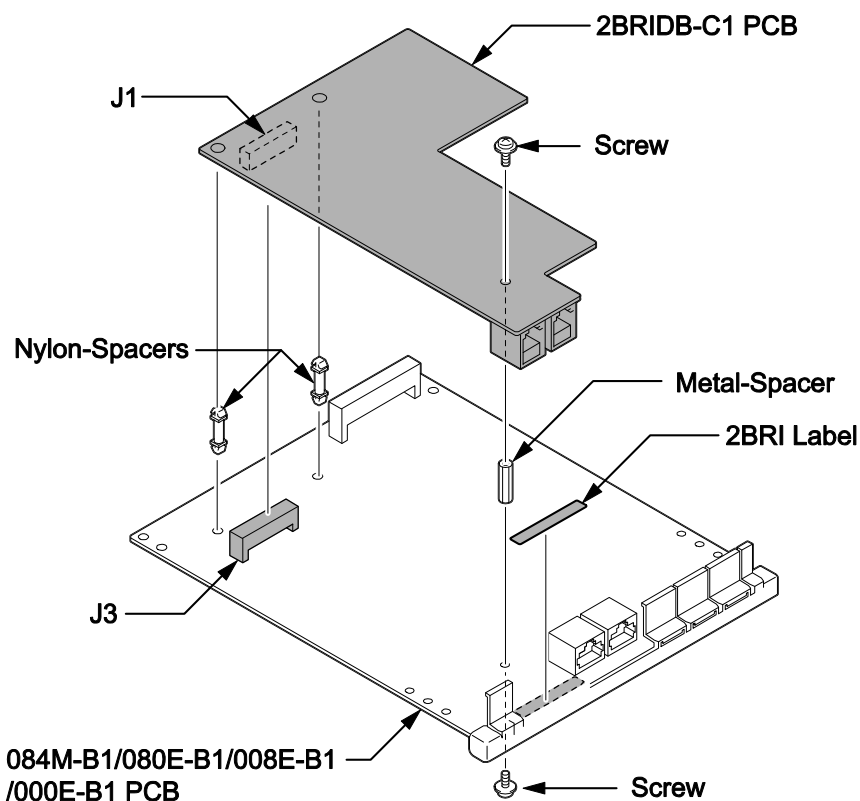

Figure 2-65 Installing the 2BRIDB-C1



The 2BRIDB-C1 cannot be mounted on the 1PRIU-C1 PCB.

5. Mount the 2BRIDB-C1 with 084M-B1/080E-B1/008E-B1/000E-B1 PCB into the KSU.

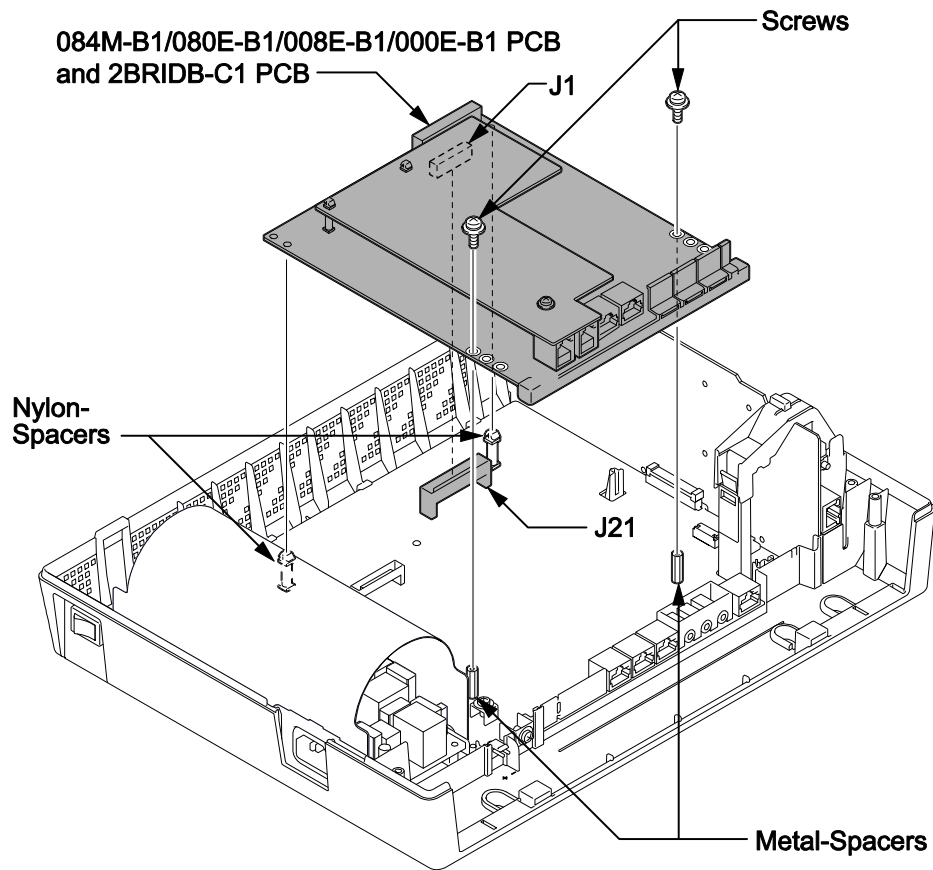

Figure 2-66 Mounting the 2BRIDB-C1 into the KSU

6. Replace the Main-Cover and fasten two screws.

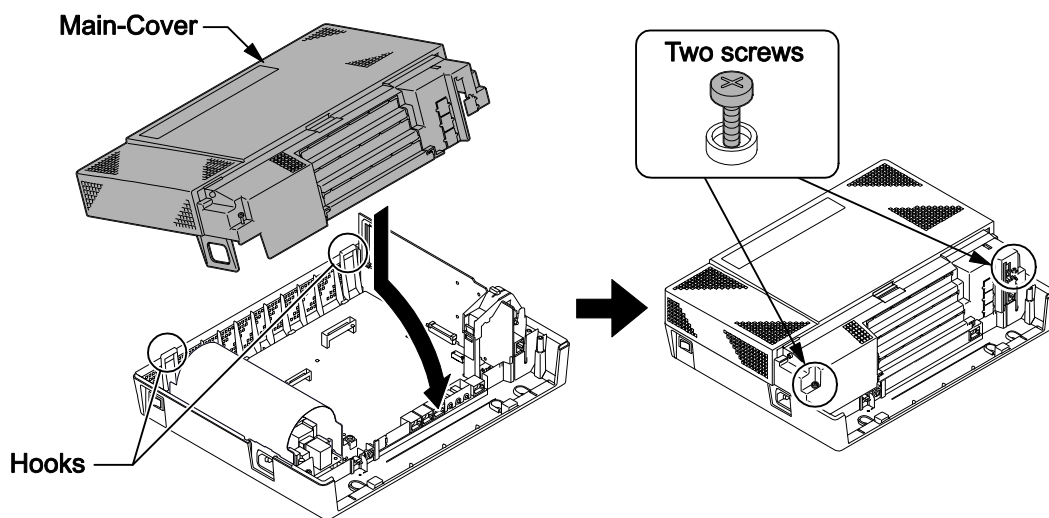

Figure 2-67 Replacing the Main-Cover

3.4 Cabling and Setting the Expansion Interface Card

Precautions for Cabling

- Do not wire the cable with an AC cable, computer, etc.
- Do not run the cable near the high frequency generating device.
- Use cable protectors in case the cables run on the floor.
- Aerial distribution wiring is not allowed.
- Trunks must be installed with lightning protectors.
- Only SL1100 terminals (12TXH, 24TXH) may be connected to a SL1100 digital port. Do not connect any other terminal as damage may result.

3.4.1 Cabling IP4WW-080E-B1

This IP4WW-080E-B1 PCB provides two RJ-61 connections for digital extensions.



Before plugging in the Multiline Telephone, DSS Console, Single line Telephone or Doorphone, ensure Main KSU is powered off.



Only SL1100 terminals (12TXH, 24TXH) may be connected to a SL1100 digital port. Do not connect any other terminal as damage may result.

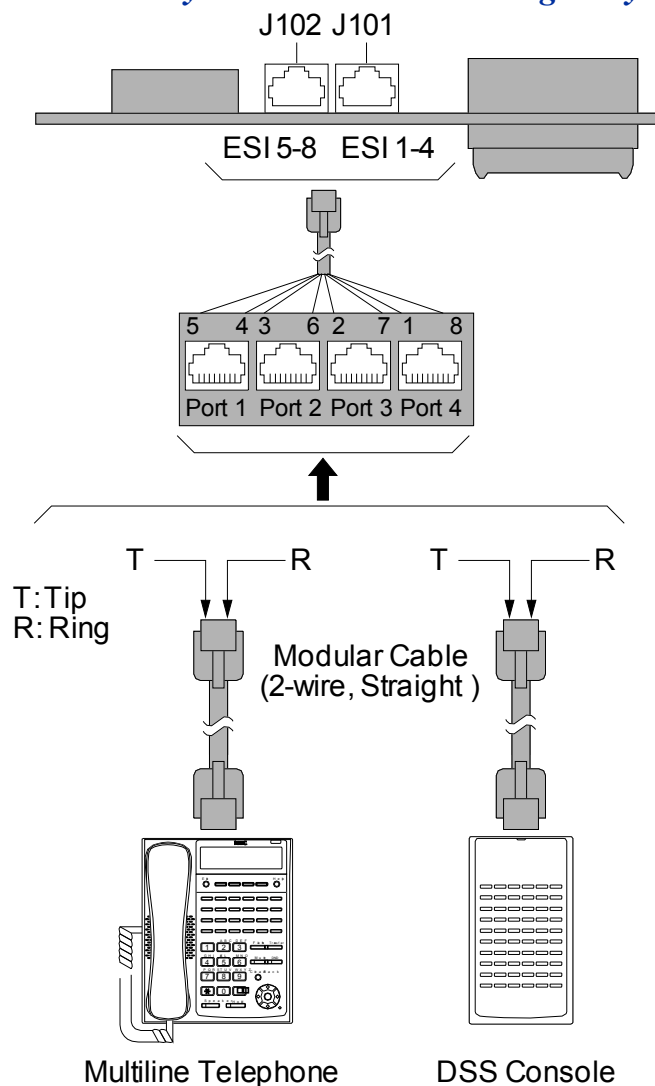
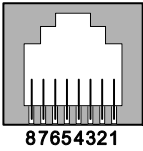

Figure 2-68 Connectors of 080E-B1

3.4.1.1 Connectors

The following table shows the pin-outs for the RJ-61 cable connector for Digital extension connections.

Table 2-9 RJ-61 Digital Connector Pin-Outs (J101, J102)

	Pin No.	ESI 1-4 (J101), ESI 5-8 (J102): 2-Wire Digital Extension Port Connector (RJ-61)
	1	T4 (Tip for port 4)
	2	T3 (Tip for port 3)
	3	T2 (Tip for port 2)
	4	R1 (Ring for port 1)
	5	T1 (Tip for port 1)
	6	R2 (Ring for port 2)
	7	R3 (Ring for port 3)
	8	R4 (Ring for port 4)

3.4.2 Cabling IP4[]-008E-B1

This IP4[]-008E-B1 PCB provides two RJ-61 connections for analogue extensions.



Before plugging in the Multiline Telephone, DSS Console, Single line Telephone or Doorphone, ensure Main KSU is powered off.



Only SL1100 terminals (12TXH, 24TXH) may be connected to a SL1100 digital port. Do not connect any other terminal as damage may result.

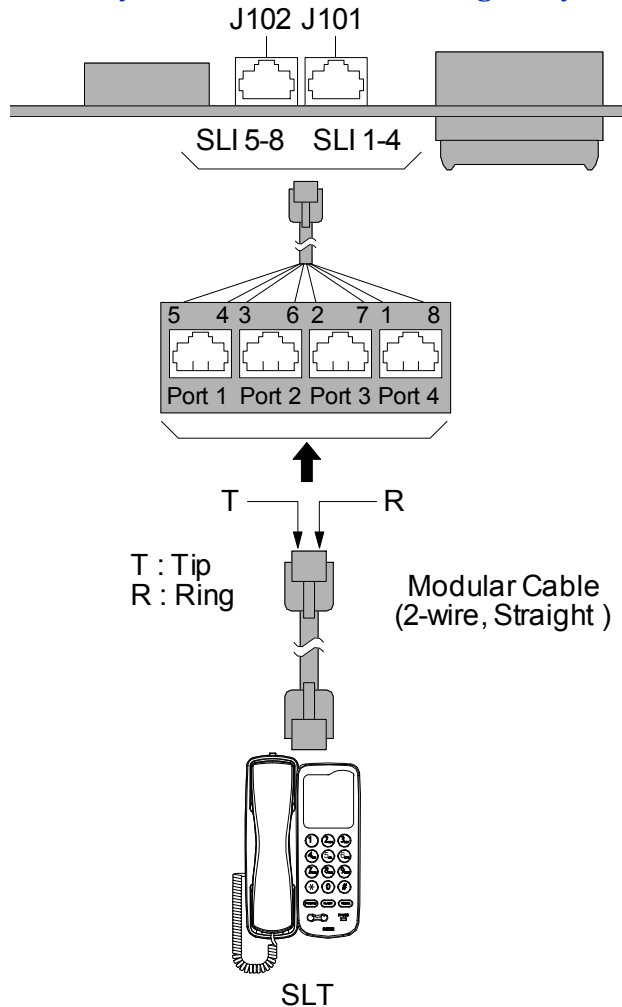

Figure 2-69 Connectors of 008E-B1



While an Analogue Telephone (port) is ringing or MW-lamp is flashing on an Analogue Phone (port), do not disconnect the phone from the port and or connect another type of the terminal to this port.

3.4.2.1 Connectors

The following table shows the pin-outs for the RJ-61 cable connector for Analogue extension connections.

Table 2-10 RJ-61 Analogue Pin-Outs (J101, J102)

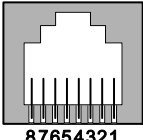
	Pin No.	SLI 1-4 (J101), SLI 5-8 (J102): 2-Wire Analogue Extension port Connector (RJ-61)
		1
	2	T3 (Tip for port 3)
	3	T2 (Tip for port 2)
	4	R1 (Ring for port 1)
	5	T1 (Tip for port 1)
	6	R2 (Ring for port 2)
	7	R3 (Ring for port 3)
	8	R4 (Ring for port 4)

3.4.3 Cabling IP4WW-000E-B1

This IP4WW-000E-B1 PCB does not have any connection for cabling.

3.4.4 Cabling and Setting IP4WW-4COIDB-B1

This IP4WW-4COIDB-B1 PCB provides two RJ-61 connections for CO lines (J2) and PFT TEL (J3).

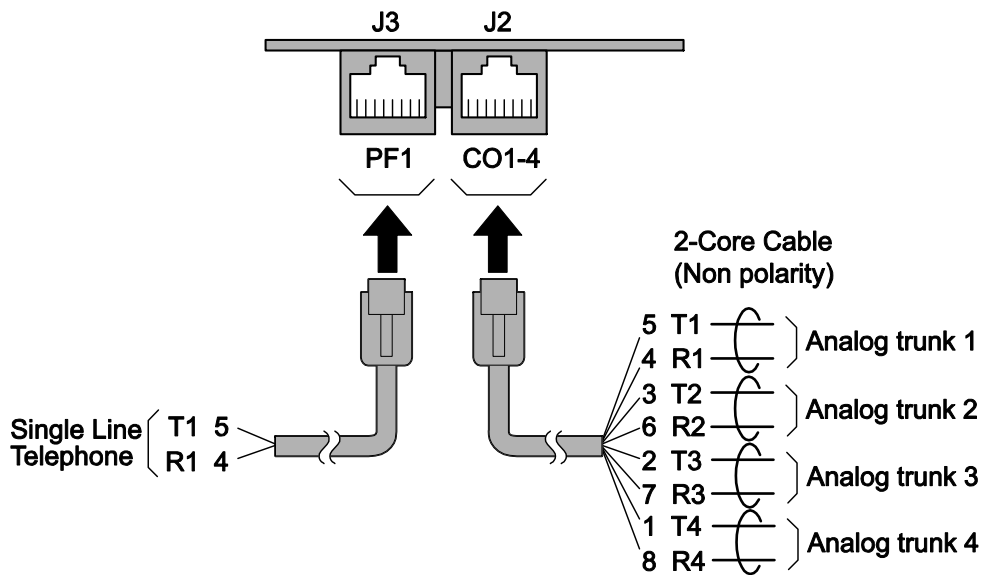
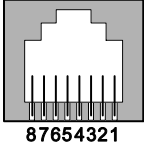

Figure 2-70 Connectors of 4COIDB-B1

3.4.4.1 Connectors

The following table shows the pin-outs for the RJ-61 cable connector for CO (J2) and PF (J3) connections.

Table 2-11 RJ-61 CO/PF Pin-Outs (J2, J3)

	Pin No.	CO1-4 (J2): CO Port Connector (RJ-61)	PF1 (J3): PF Tel Port Connector (RJ-61)
	1	T4 (Tip for port 4)	-
	2	T3 (Tip for port 3)	-
	3	T2 (Tip for port 2)	-
	4	R1 (Ring for port 1)	R1 (Ring for port 1)
	5	T1 (Tip for port 1)	T1 (Tip for port 1)
	6	R2 (Ring for port 2)	-
	7	R3 (Ring for port 3)	-
	8	R4 (Ring for port 4)	-

3.4.5 Cabling and Setting IP4WW-2BRIDB-C1

This IP4WW-2BRIDB-C1 PCB provides two RJ-61 BRI connections.

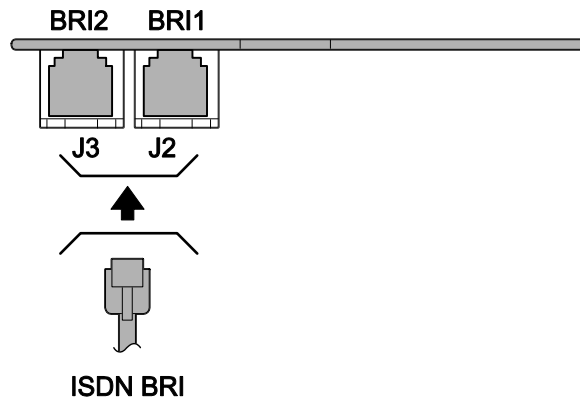
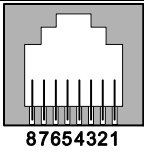

Figure 2-71 Connectors of 2BRIDB-C1

3.4.5.1 Connectors

The following table shows the pin-outs for the RJ-61 cable connector for S-Bus and T-Bus connections.

Table 2-12 RJ-61 BRI Pin-Outs (S-Bus, T-Bus)

	Pin No.	RJ-61 Cable Connector-2BRIDB-J2 (BRI1), J3 (BRI2) S-Bus Connection	RJ-61 Cable Connector-2BRIDB-J2 (BRI1), J3 (BRI2) T-Bus Connection
	1	-	-
	2	-	-
	3	RA	TA
	4	TA	RA
	5	TB	RB
	6	RB	TB
	7	-	-
	8	-	-

3.4.5.2 Switch Setting

Switches Location of 2BRIDB-C1 shows the location of the connectors and switches on the IP4WW-2BRIDB-C1.

1. Set the switches J12 to J17 according to the system, referring the Switch Setting of 2BRIDB-C1.

Table 2-13 Switch Setting of 2BRIDB-C1

Switch No.	Switch Position	Description
J12/J15	ON (default)	Termination register is ON. This SW should be ON in case: <ul style="list-style-type: none"> • T-Bus Point-to-Point connection is selected.

Switch No.	Switch Position	Description
		<ul style="list-style-type: none"> T-Bus Point-to-Multipoint is selected, and if the system is Terminal 8. (last device on the bus) S-Bus.
	OFF	P-MP (Terminal 7)
J13, J14/J16, J17	T (default)	T-Bus connection
	S	S-Bus connection



J12 & J15 do not configure the connection type on the system, they only add/remove the termination of the circuit.

J13, J14 & J16, J17 do not configure the connection type on the system, they only select the polarity of the connector J2/J3. The 2BRIDB-C1 circuits must also be setup within the system configuration.

- Connect the cables from the NT1 Network Termination cable to the J2 or J3 connector on the 2BRIDB-C1 daughter board.
Connector J2 - BRI1: Use switches J12, J13, J14
Connector J3 - BRI2: Use switches J15, J16, J17



Ensure that you set all switches correctly for each BRI circuit.

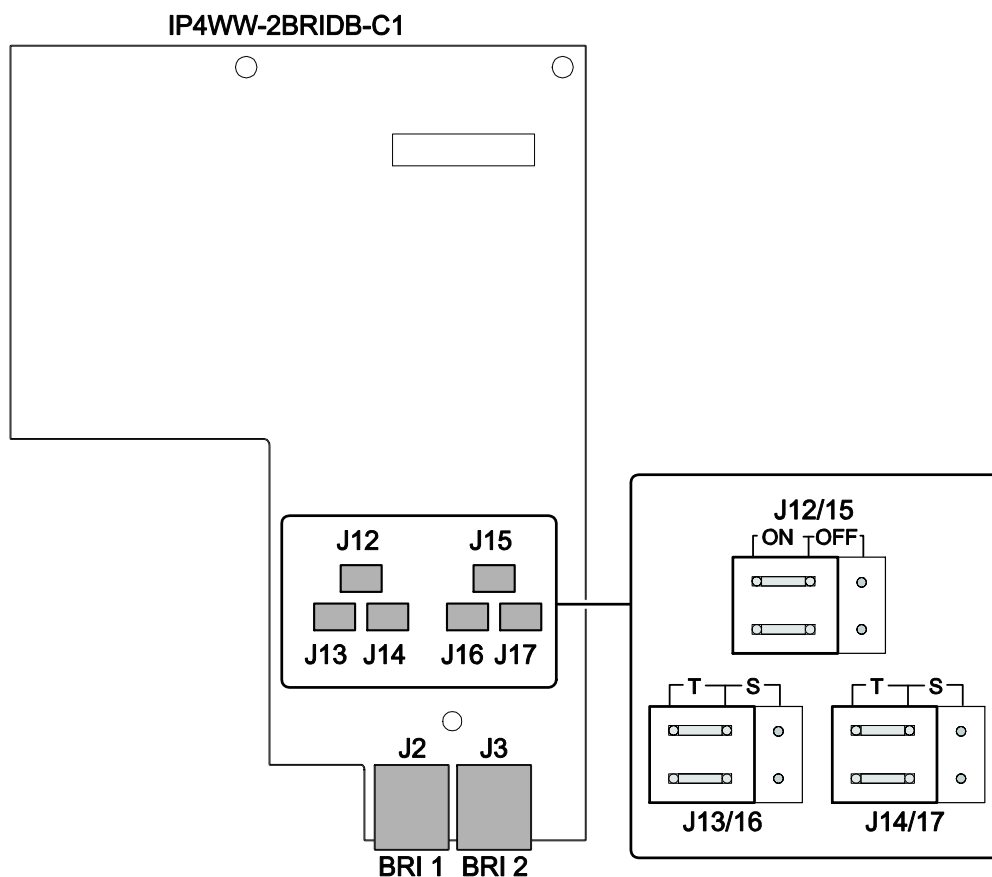

Figure 2-72 Switches Location of 2BRIDB-C1

3.4.6 Cabling and Setting IP4WW-1PRIU-C1

This IP4WW-1PRIU-C1 PCB provides one RJ-45 PRI connection.

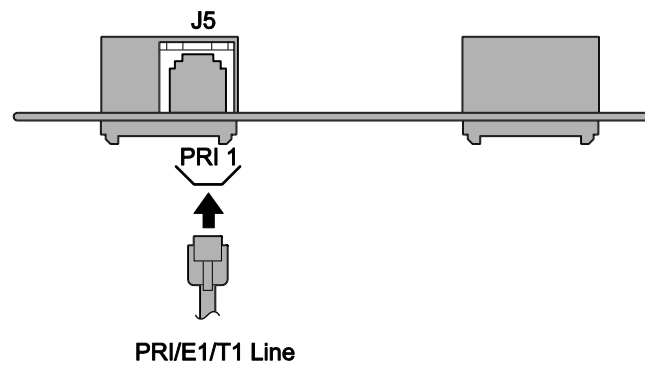
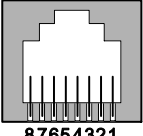

Figure 2-73 Connector of 1PRIU-C1

3.4.6.1 Connector

Following table shows the pin-outs for the RJ-45 cable connector for S-Bus and T-Bus RJ-45 connections.

Table 2-14 RJ-45 PRI Pin-Outs (S-Bus, T-Bus)

 87654321	Pin No.	RJ-45 Cable Connector- PRI 1 (J5) S-Bus Connection	RJ-45 Cable Connector- PRI 1 (J5) T-Bus Connection
		1	TA
	2	TB	RB
	3	-	-
	4	RA	TA
	5	RB	TB
	6	-	-
	7	-	-
	8	-	-

3.4.6.2 Switch Setting

The following figure shows the location of the switches and LEDs on the IP4WW-1PRIU-C1 Card.

1. Set the switches J6 to J9 according to the system, referring the Switch Setting of 1PRIU-C1.

Table 2-15 Switch Setting of 1PRIU-C1

Switch No.	Switch Position	Description
J6, J7	2M (default)	Connect PRI/E1 (2.048 Mb/s) line
	1.5M	Connect PRI/T1 (1.544 Mb/s) line
J8, J9	T (default)	T-Bus connection
	S	S-Bus connection

2. Connect the cables from the NT1 Network Termination cable to the J5 connector on the 1PRIU-C1 Card.
3. Assign whether the unit works as PRI/T1/E1 by PRG10-51-01.



With normal operation, D4 LED flashes green.

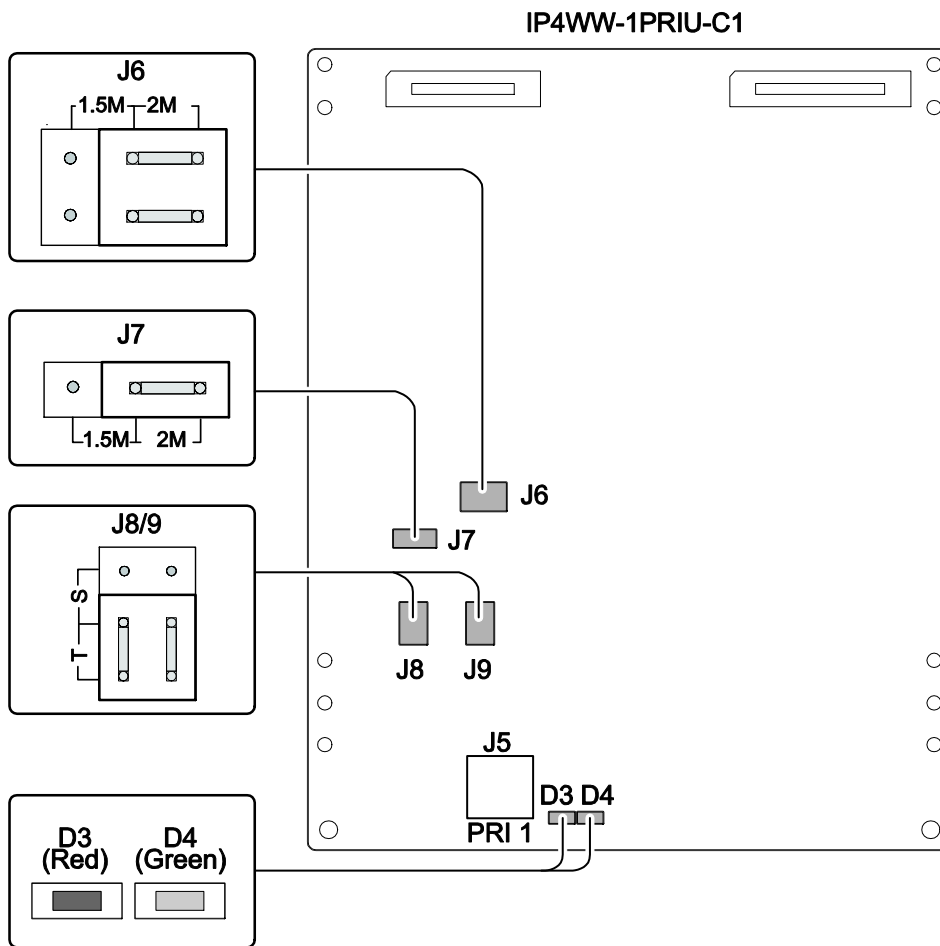

Figure 2-74 Switches and LEDs Location of 1PRIU-C1

3.4.6.3 LED Indication

LED indications for the IP4WW-1PRIU-C1 are listed in following table. Each LED is listed with its associated function and LED and operational status.

Table 2-16 LED Indication

LED Indication		Operation Status		Remarks
Live LED (D4) (Green)	Busy LED (D3) (Red)			
On	On	System Initializing		-
Flash (1s)	On	The assignment of the unit is refused		When you exceed the system capacity. When the main software version is not matched.
	Flash (1s)	Trouble found during self-diagnostics.		-
Flash (100ms)	On	Normal Operation	A Channel is busy (use another from Ch1 - Chx)	-
	Off		All channels are Idle.	-
Off	On	Unit Busy	A Channel is busy (use another from Ch1 - Chx)	-
	Off		All channels are Idle.	-
	Flash 80ms (On/Off) x3/ 400ms Off		Downloading firmware	-

3.5 Power Failure Transfer (4COIDB-B1 only)

3.5.1 General

In the event of AC power failure, the specified trunk is directly connected to the specified extension port as below. And SLT must be connected to the specified extension. The multiline telephone (2W) does not work when the specified trunk is connected to the specified extension port.

J2 (CO1-4): Trunk Port 1 → J3 (PF1): Extension Port 1

Refer to RJ-61 CO/PF Pin-Outs (J2, J3) for wiring of the power failure telephone.



The connected extension must be SLT (Single Line Telephone).

SECTION 4 INSTALLING THE OPTIONAL INTERFACE CARDS

4.1 Installing the Expansion Memory Card (MEMDB-C1)

4.1.1 General

The Memory expansion daughter board (IP4[]-MEMDB-C1) provides additional memory for the system to use following features;

- To use VoIP Card (IP4WW-VOIPDB-C1)
- E-Mail Notification (InMail)
- VRS/InMail channel increase from 8 to 16 channels
- Virtual Loopback

This daughter board is mounted on the CPU card and provides the SDRAM and flash memories.

4.1.2 Unpacking

Table 2-17 MEMDB-C1 Packing List

Items	List of Contents	QTY
IP4[]-MEMDB-C1	MEMDB-C1 PCB	1

4.1.3 Installing the MEMDB PCB



Do not remove or install the CPU card with power on.

1. Turn off the system power and disconnect AC cord.
2. Open and remove the Sub-Cover.

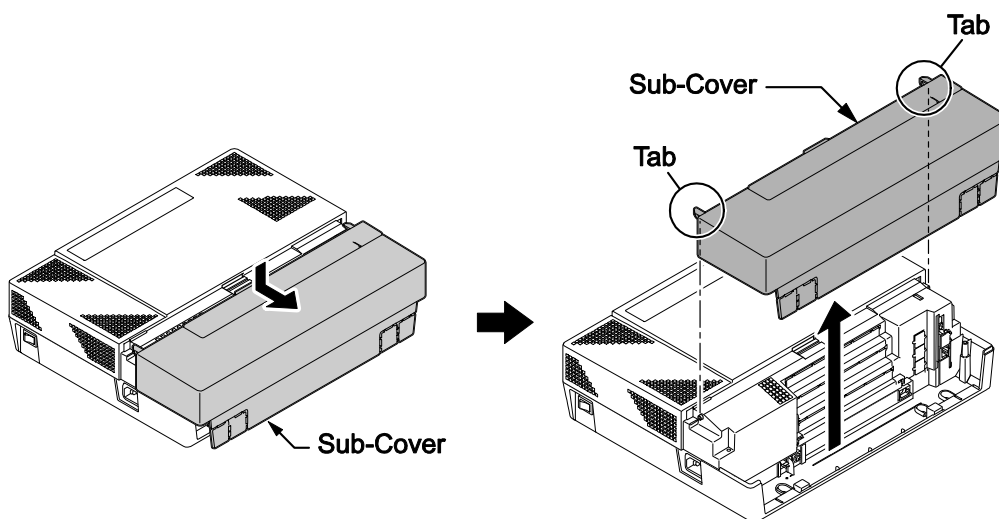

Figure 2-75 Removing the Sub-Cover

3. Loosen two screws and remove the Main-Cover.

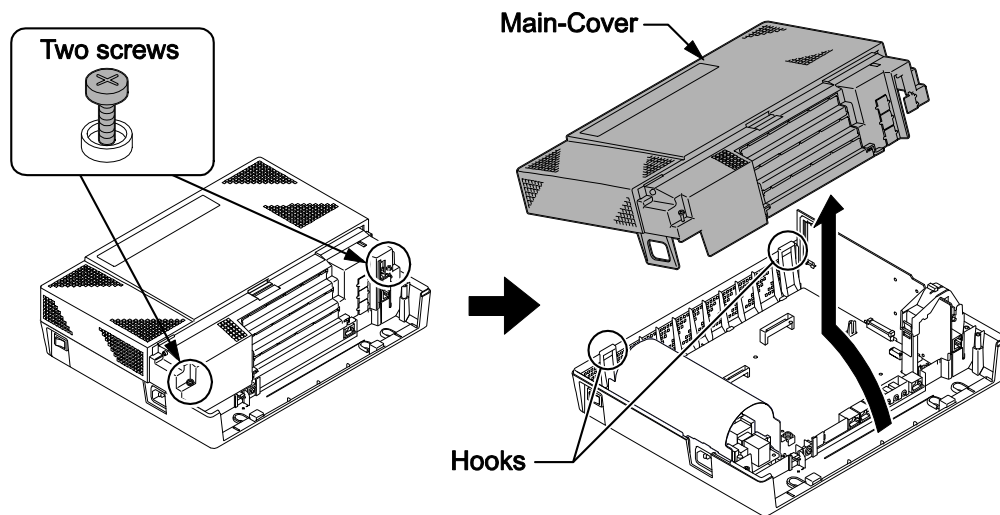

Figure 2-76 Removing the Main-Cover

4. Press tab A and lift the CPU support bracket. Remove the CPU card.

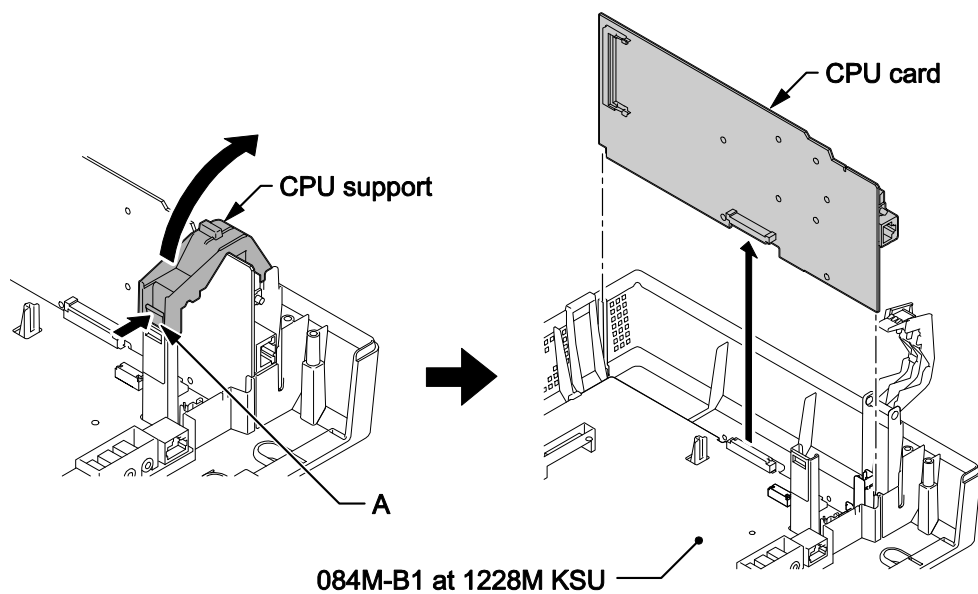

Figure 2-77 Removing the CPU Card

5. Insert the MEMDB-C1 daughter board to J4 socket on the CPU card and press down the MEMDB-C1 daughter board to secure.



Both levers must be secured to notch-A.

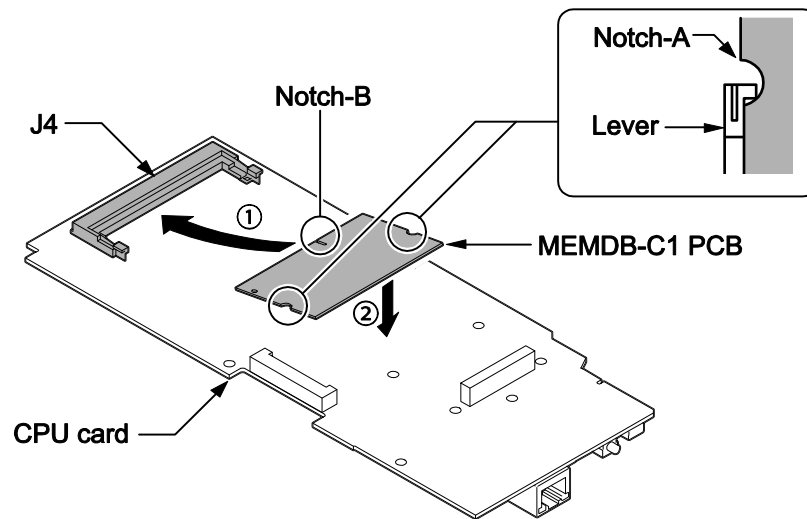

Figure 2-78 Installing the MEMDB PCB

6. Reinstall the CPU card into the 084M-B1 mother board, and close the CPU support making sure the tab A locks into place.

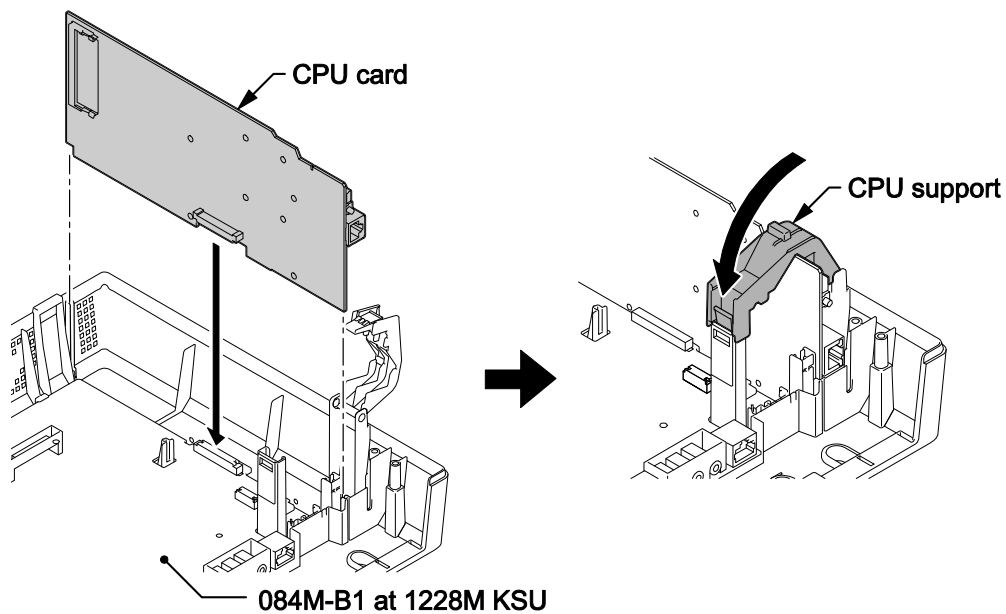

Figure 2-79 Installing the CPU Card

7. Replace the Main-Cover and fasten two screws.

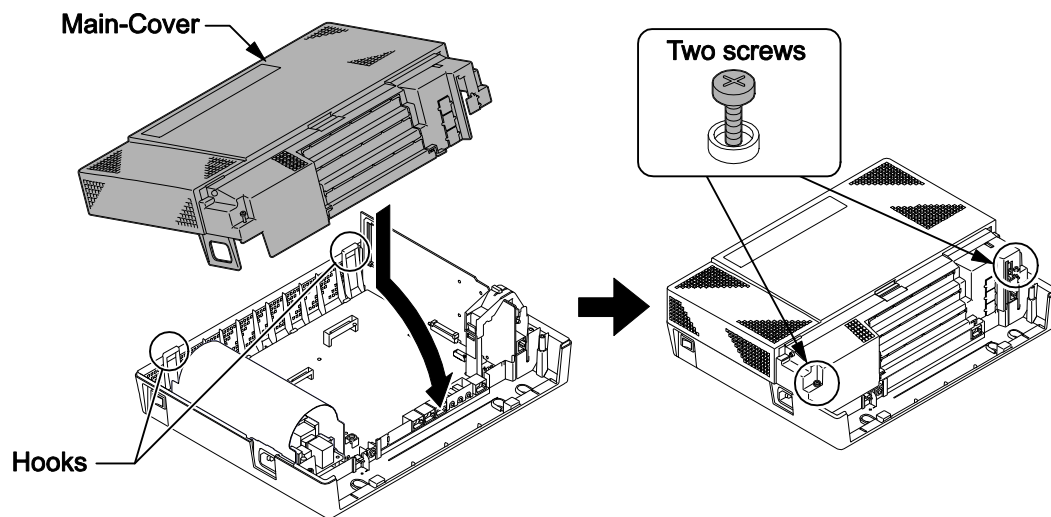

Figure 2-80 Replacing the Main-Cover

4.2 VoIP Card (VOIPDB-C1)

4.2.1 General

The IP4WW-VOIPDB-C1 daughter board is used to convert the RTP (Real Time Transfer Protocol) packets via the IP Network and PCM highway. The daughter board is installed on the CPU card.

4.2.2 Unpacking

Table 2-18 VOIPDB-C1 Packing List

Items	List of Contents	QTY
IP4WW-VOIPDB-C1	IP4WW-VOIPDB-C1	1
	Ferrite Core (for Ethernet Cable)	1

4.2.3 Installing the VOIPDB-C1 PCB



Do not remove or install the CPU Card with the power on.

1. Turn off the system power and disconnect AC cord.
2. Open and remove the Sub-Cover.

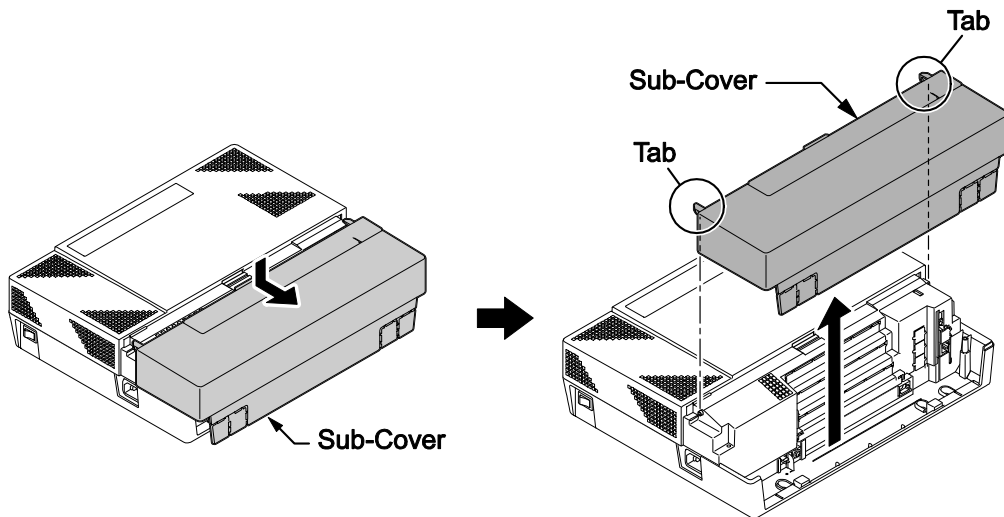

Figure 2-81 Removing the Sub-Cover

3. Loosen two screws and remove the Main-Cover.

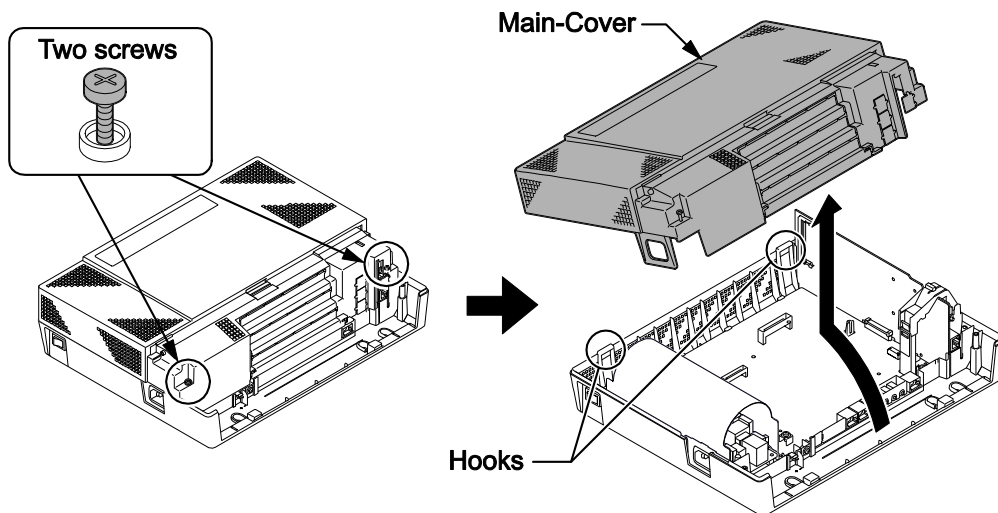

Figure 2-82 Removing the Main-Cover

4. Press tab A and lift the CPU support bracket. Remove the CPU card.

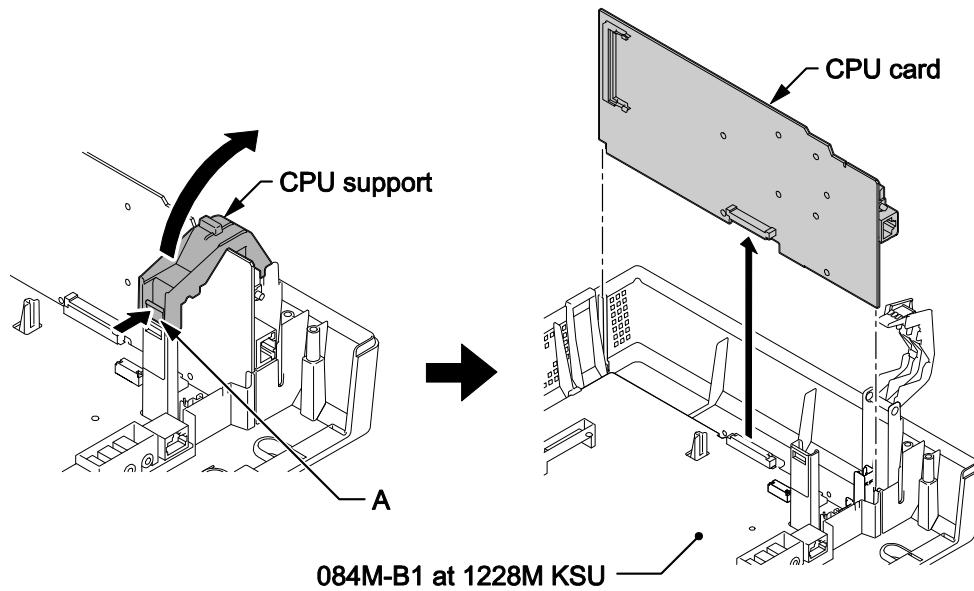

Figure 2-83 Removing the CPU Card

5. Install the VOIPDB-C1 daughter board to J5 connector on the CPU card.

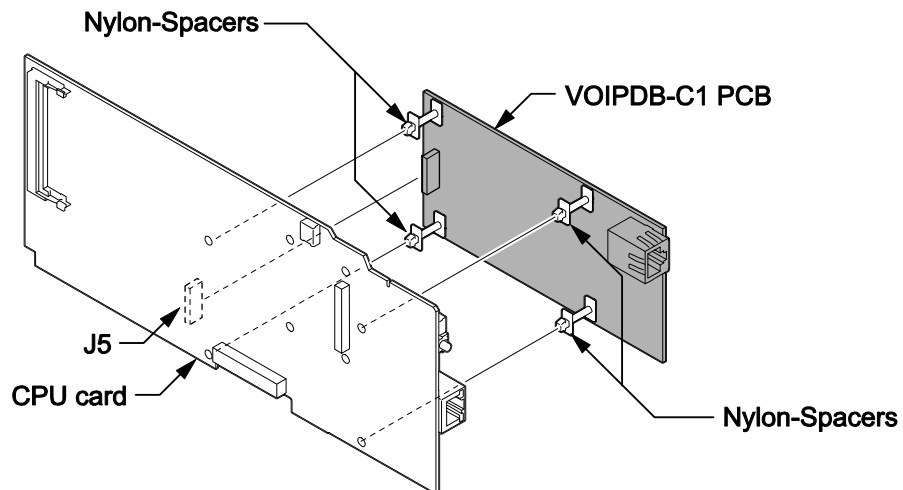

Figure 2-84 Installing the VOIPDB-C1 PCB

6. Reinstall the CPU card into the 084M-B1 mother board, and close the CPU Support making sure tab A locks into place.

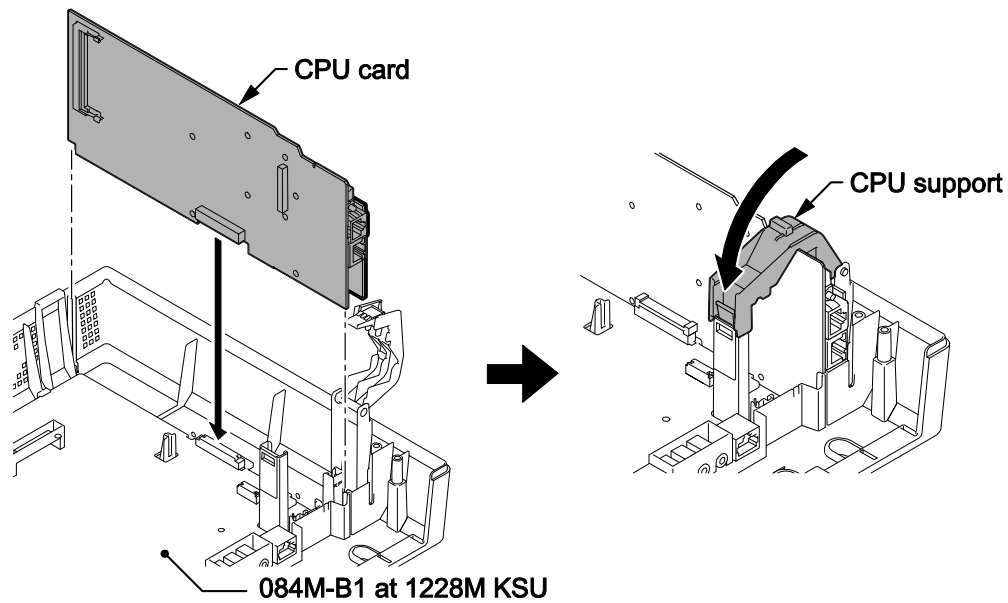

Figure 2-85 Installing the CPU Card

7. Cut and remove the Plastic Knockout for VoIP connector, then replace the Main-Cover and fasten two screws.

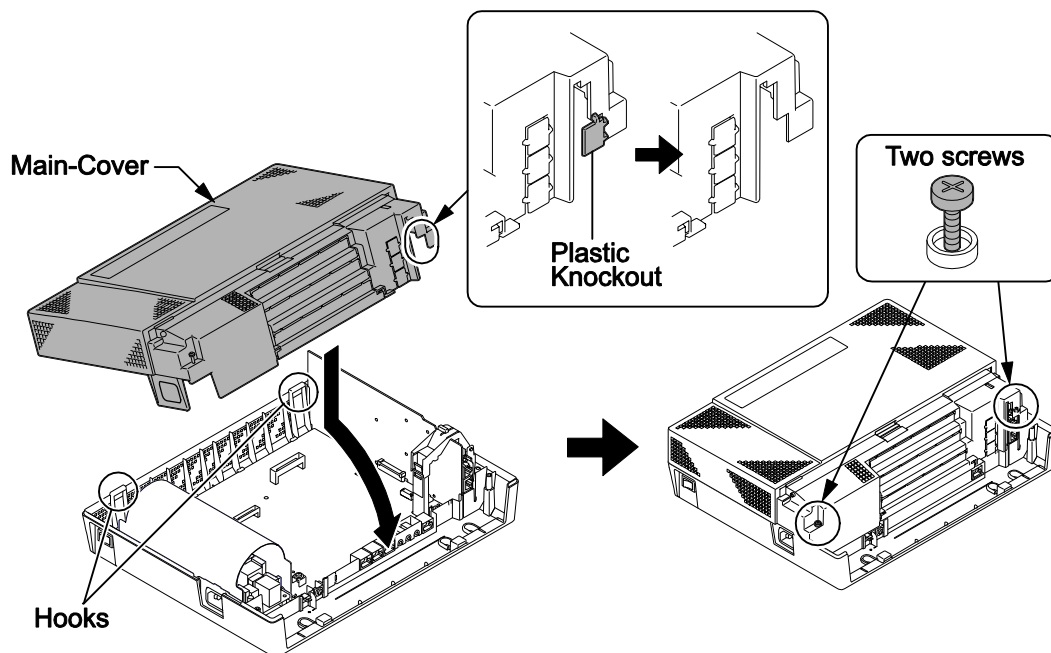

Figure 2-86 Removing the Plastic Knockout and Replacing the Main-Cover

8. Connect the VOIPDB-C1 to an Switching hub using an LAN Cable.

The LAN Cable must pass two times (two rounds) through the Ferrite Core as below. (Ferrite Core is attached with VOIPDB-C1)

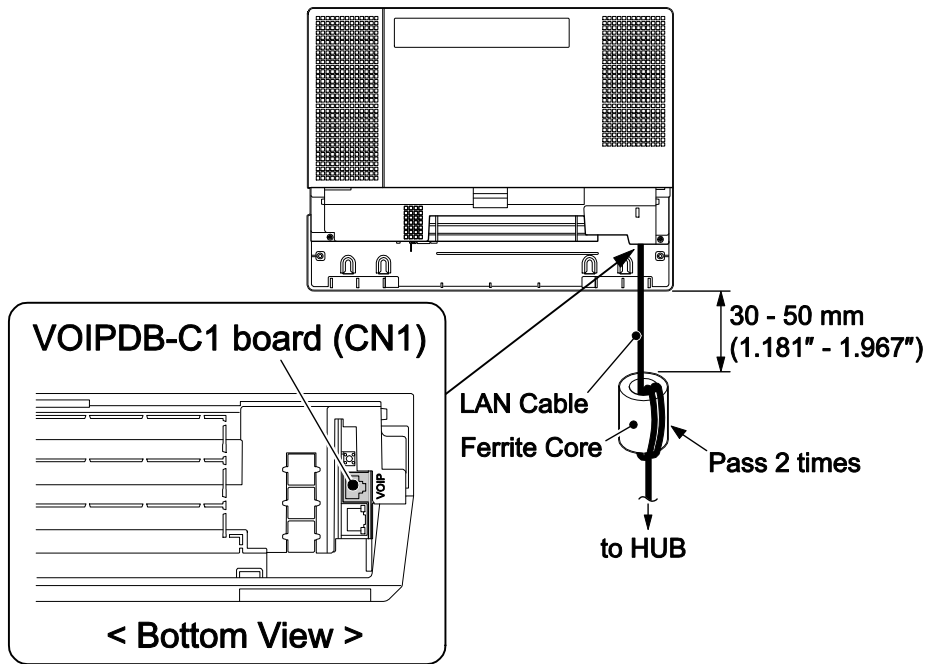

Figure 2-87 Connecting a LAN Cable

9. Refer to the SL1100 Programming Manual for detailed programming instructions.
The VoIP feature requires system configuration.

4.2.4 LED Indication

LED indications for the IP4WW-VOIPDB-C1 are listed VOIPDB LED Indications. Each LED is listed with its associated function and operational status.

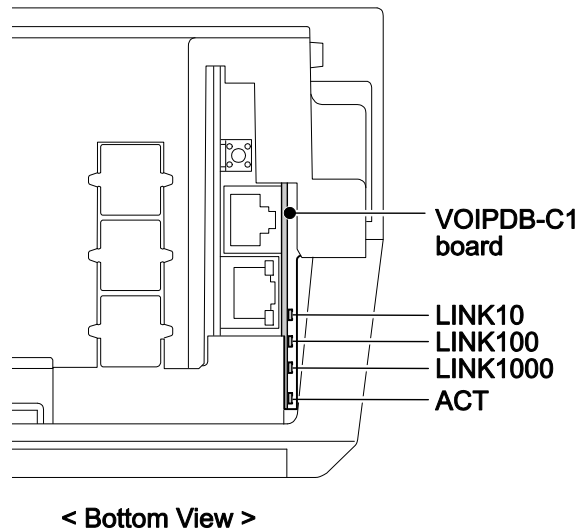

Figure 2-88 Location of LEDs

Table 2-19 VOIPDB LED Indications

LED	Function	LED Status	Operation status
ACT	Link activity or data transmission and reception.	On Green	LED lights when link up is completed. LED flash when data is transmitting or receiving.
LINK1000	1000Base-T link speed indicator	On Yellow	Lights up when 1000Base-T link up.
LINK100	100Base-TX link speed indicator.	On Red	Lights up when 100Base-TX link up.
LINK10	10Base-TX link speed indicator.	On Red	Lights up when 10Base-T link up.

Table 2-20 Operation of VOIPDB LED Indications

LED				Operation status
ACT	LINK1000	LINK100	LINK10	
Off	Off	Flash	Flash	Internal Error (Hardware Error)
Off	On	Flash	Flash	
On	On	Flash	Flash	
On	Off	Flash	Flash	State of half duplex transmission (Not support) Please change HUB etc. to full duplex transmission.
Flash	Blinking one by one			The firmware is being updated.

4.3 VRS/Voice Mail Card (PZ-VM21)

4.3.1 General

The PZ-VM21 daughter board provides additional DSP resource with 8/16 ch VRS (Voice Response system) and Voice Mail Service (a compact flash card (CFVMS) is required) and a Single Channel V.34 (33.6 kbps) modem for remote maintenance functions. The daughter board is installed onto the CPU card.

4.3.2 Unpacking

Table 2-21 PZ-VM21 Packing List

Items	List of Contents	QTY
PZ-VM21	PZ-VM21 PCB	1
	Nylon Spacers	4

4.3.3 Installing the PZ-VM21 PCB



Do not remove or install the CPU Card with the power on.

1. Turn off the system power and disconnect AC cord.
2. Open and remove the Sub-Cover.

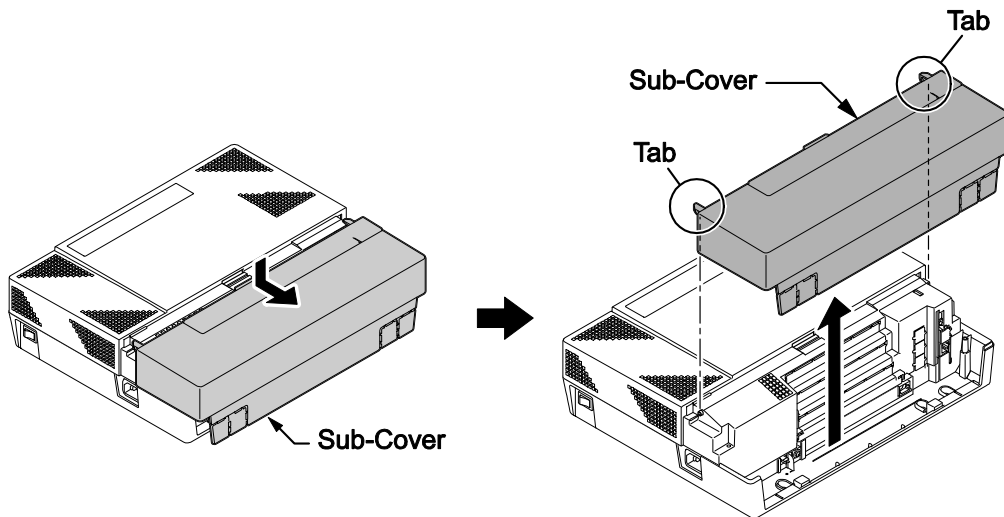

Figure 2-89 Removing the Sub-Cover

3. Loosen two screws and remove the Main-Cover.

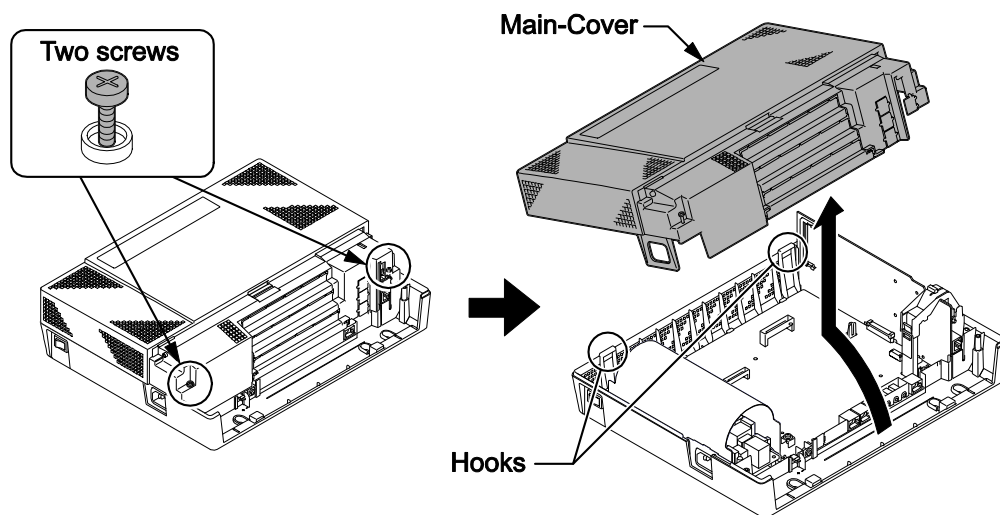

Figure 2-90 Removing the Main-Cover

4. Press tab A and lift the CPU support bracket. Remove the CPU card.

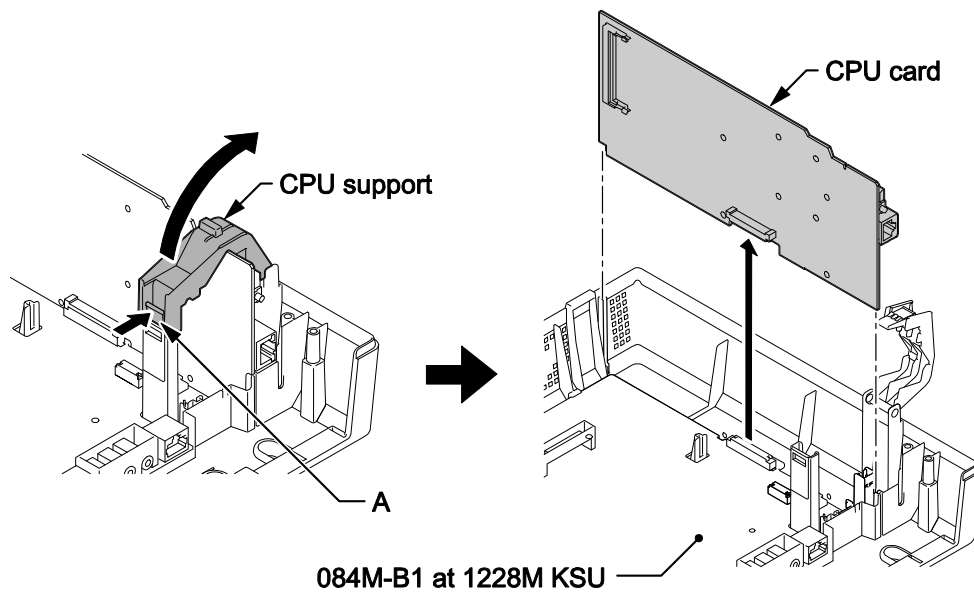

Figure 2-91 Removing the CPU Card

5. Connect the PZ-VM21 daughter board to the J6 connector using four Nylon-spacers on the CPU card.

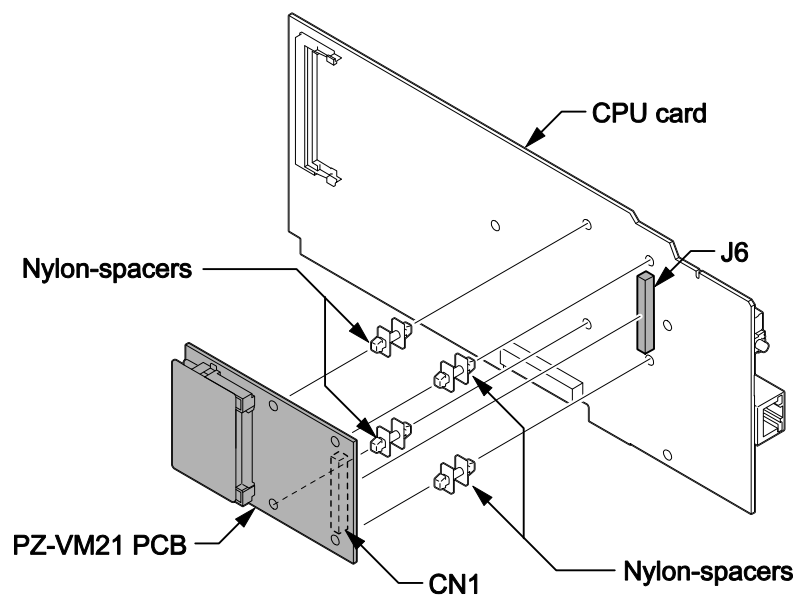

Figure 2-92 Installing the PZ-VM21 PCB

6. Reinstall the CPU card into the 084M-B1 mother board, and close the CPU Support making sure tab A locks into place.

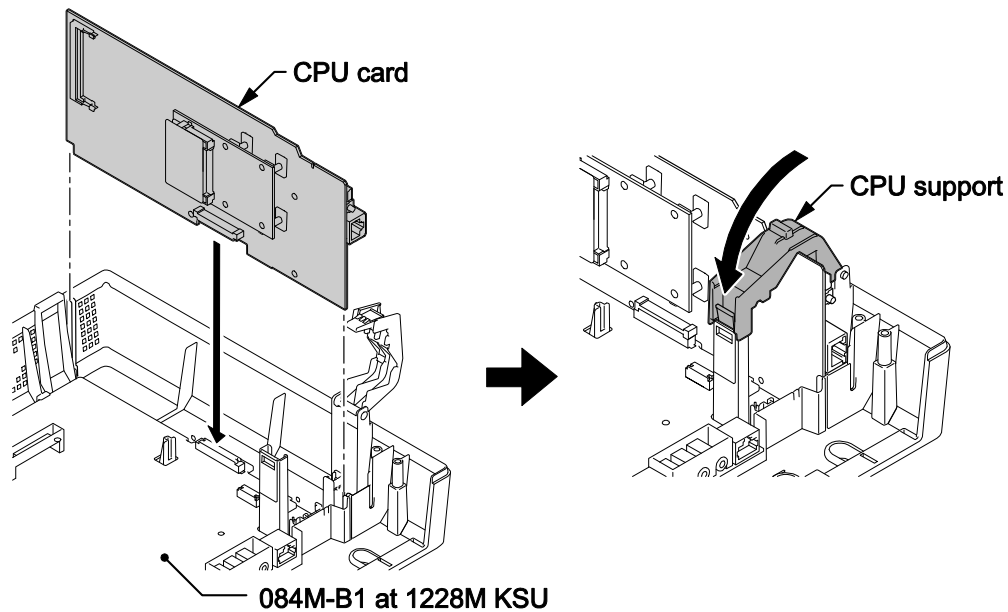

Figure 2-93 Installing the CPU Card

7. Replace the Main-Cover and fasten two screws.

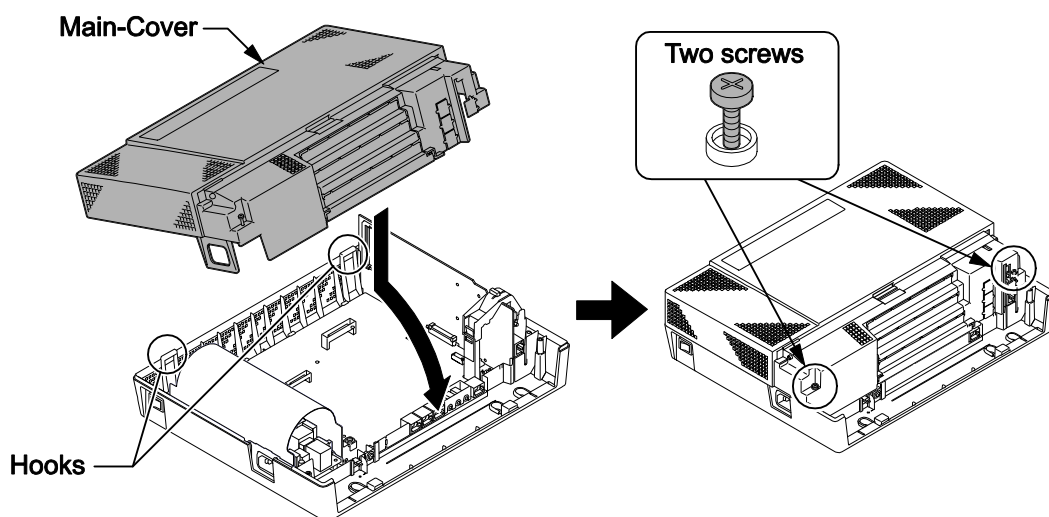

Figure 2-94 Replacing the Main-Cover

4.4 Installing the CF Card (CFVMS)



When installing a compact flash card onto the PZ-VM21 the system MUST be powered off. Never install or uninstall the compact flash card while the system is under power.

1. Turn off the system power and disconnect AC cord.
2. Remove the CPU card and insert the compact flash card into the CF slot (CN2).

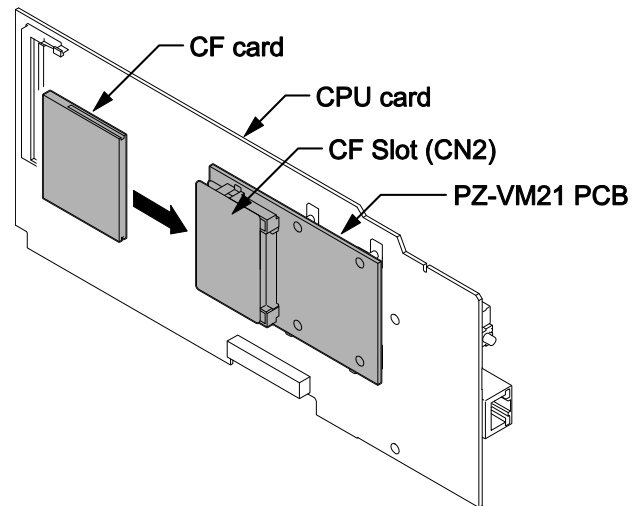

Figure 2-95 Installing the CF Card

3. Reinstall the CPU card into the 084M-B1 mother board, and close the CPU Support making sure tab A locks into place.

SECTION 5 INSTALLING THE MULTILINE TELEPHONES AND OPTIONAL TERMINALS

5.1 Installing the Multiline Telephones

There are three types of Multiline Telephones available in the SL1100 system.

- IP4WW-12TXH-B-TEL
- IP4WW-24TXH-B-TEL
- IP4WW-24TIXH-C-TEL (IP)

5.1.1 Location of Controls

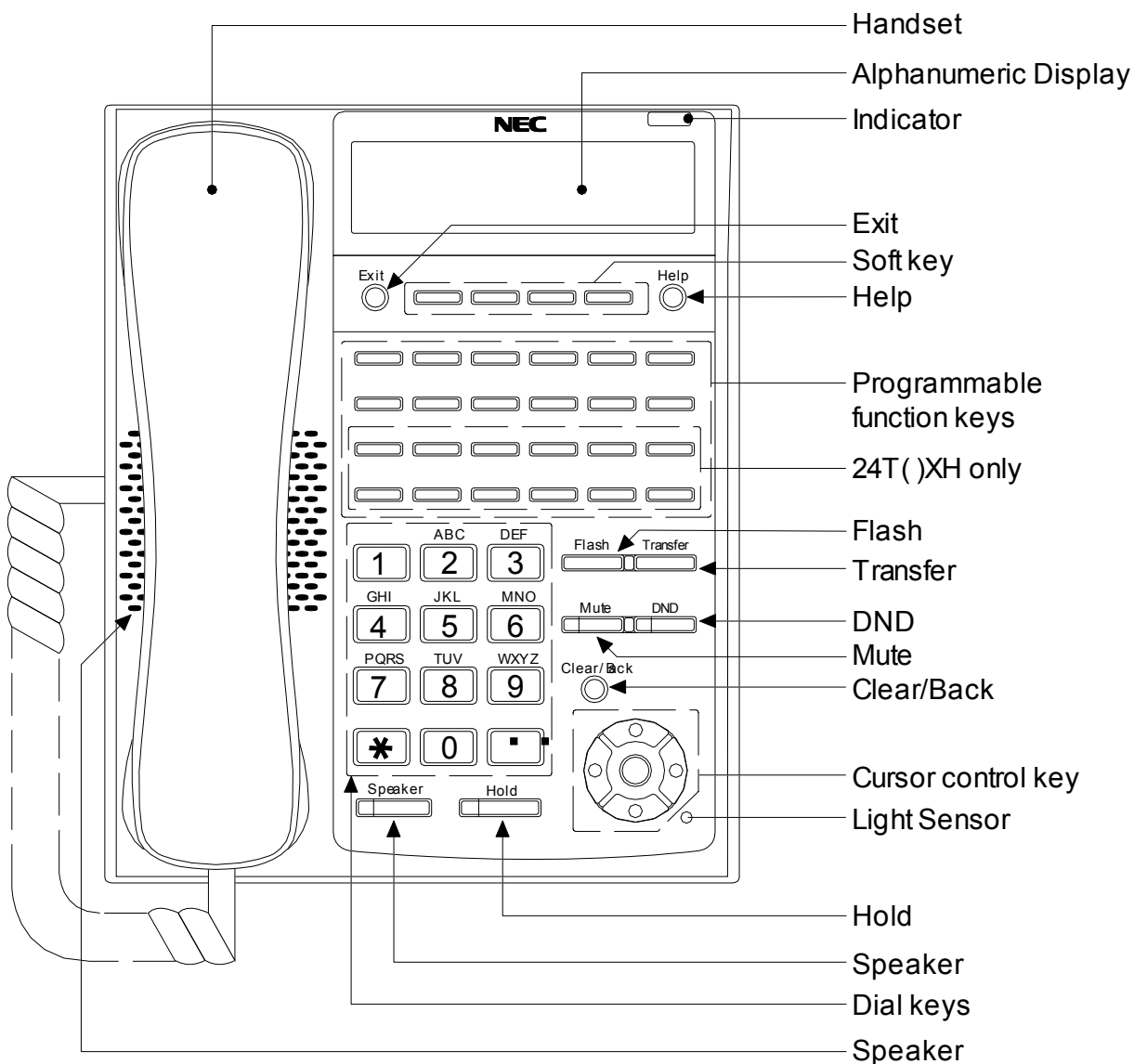

Figure 2-96 Multiline Telephone (12TXH/24TXH/24TIXH (IP))

Table 2-22 Multiline Telephone Functions (12TXH/24TXH/24TIXH (IP))

Functions	12TXH	24TXH	24TIXH
Programming Keys	12 (Busy lamp field: Red-Green)	24 (Busy lamp field: Red-Green)	24 (Busy lamp field: Red-Green)
Display	24-digit x 3 lines with Backlit		
Handsfree	Full-duplex		
Wall-Mount Kit	Yes (Built-in)		Yes (Optional)
SoftKeys	Yes		
Backlit Dial Pad	Yes		
Incoming LED	2 colors (Red/Green)		
Connected to	Digital Extension Port		Ethernet Port on the Network
Headset Port	Yes		
Power Feeding	-	-	AC Adapter (DC27 V,1 A) or PoE (IEEE802.3af)

5.1.2 Multiline Telephone Legs Adjustment

The Multiline Telephone provides adjustable legs for angling the phone to best suit each user. The leg can be set for two different heights (Low/High).

5.1.2.1 Low Position Setting

1. Turn telephone over (button side down).
2. Adjust the legs to desired height.

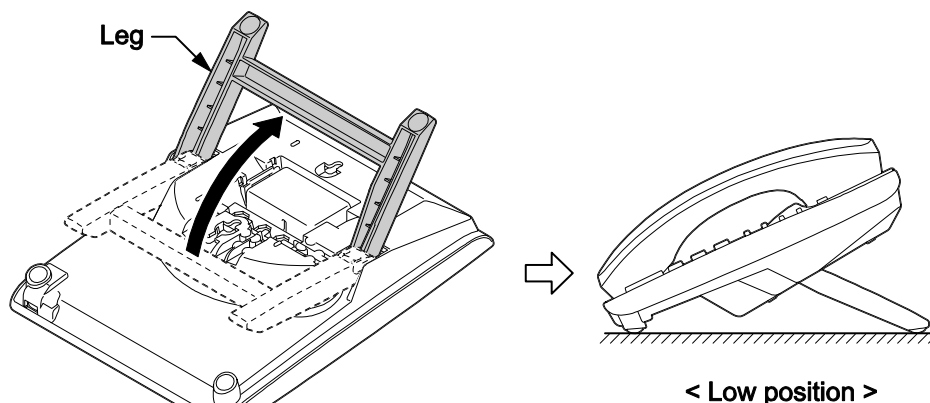

Figure 2-97 Leg Setting for Low Position

3. Lead the Line and Handset cords through the applicable grooves.

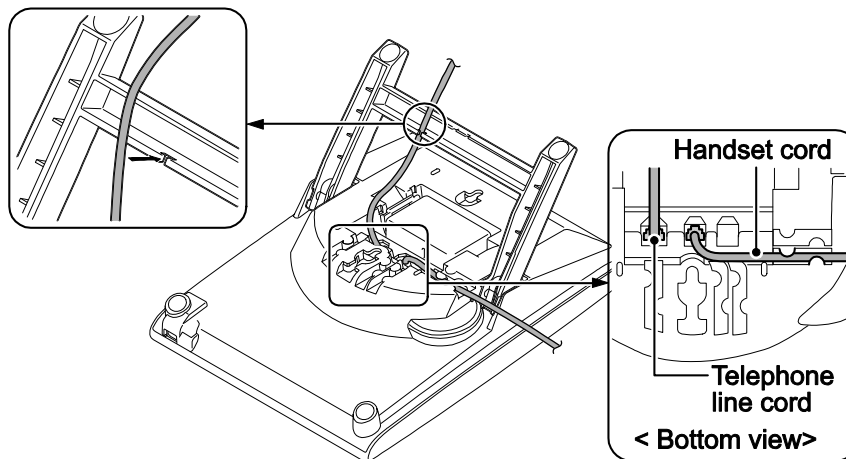

Figure 2-98 Cabling of Multiline Telephone

4. Turn telephone over (button side up).

5.1.2.2 High position setting

1. Turn telephone over (button side down).
2. Pull up the Leg Stoppers.

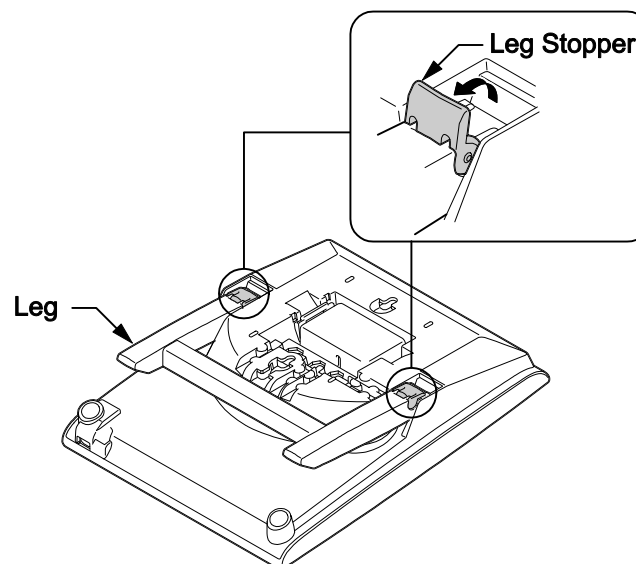

Figure 2-99 Setting for High Position

3. Adjust the leg to desired height.

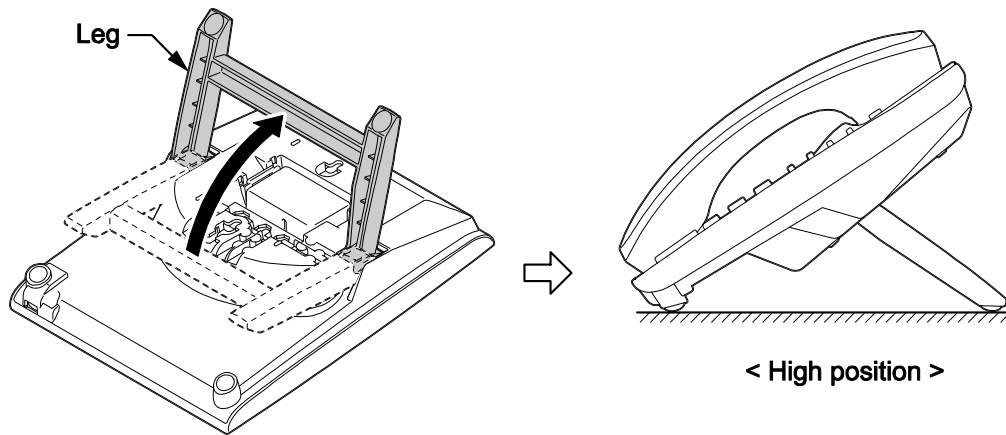

Figure 2-100 Leg Setting for High Position

4. Lead the Line and Handset cords through the applicable grooves.
(Refer to Cabling of Multiline Telephone)

5.1.3 Wall-Mounting the Multiline Telephone

1. Arrange the cables and put down the leg as shown below.

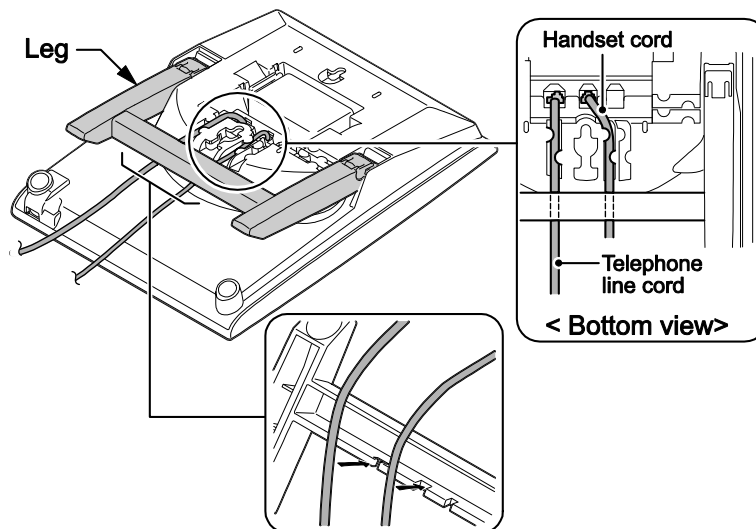

Figure 2-101 Cabling for Wall-Mount



For IP4WW-24TIXH-C only:

When wall-mounting the IP4WW-24TIXH-C, attach the IP4WW-WALL MOUNT UNIT to the bottom panel as shown.

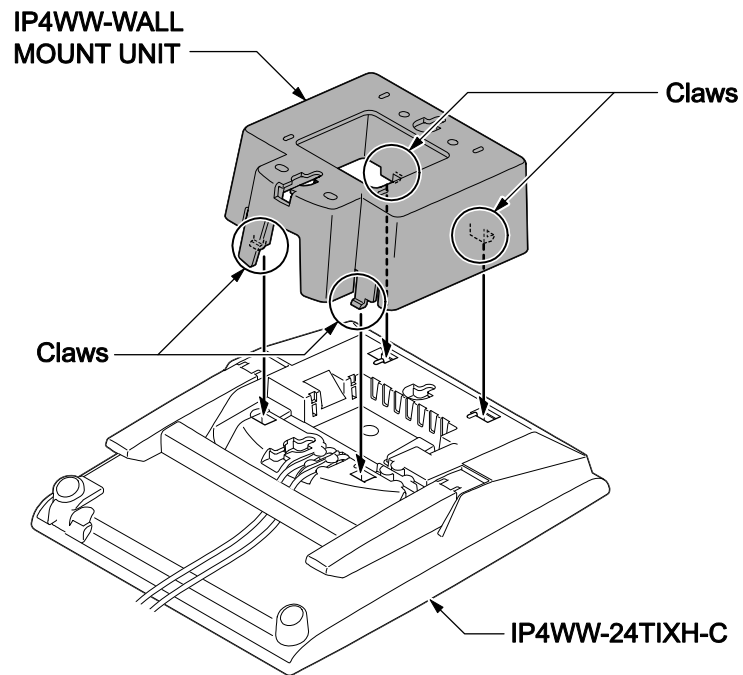

Figure 2-102 Wall-Mount Unit - 24TIXH-C

2. Remove the switch-hook from the unit. Turn the tab toward the top. Then slide the hook-switch into position. Refer to Hook-Switch Hanger.

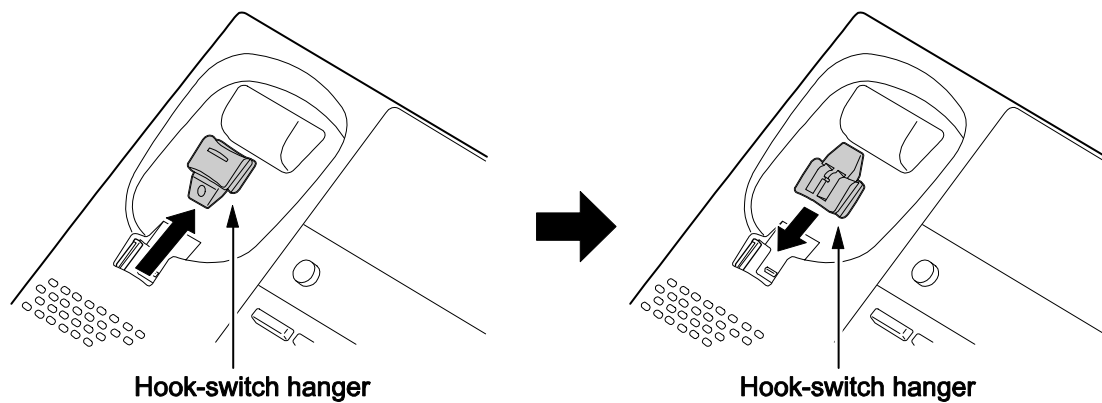

Figure 2-103 Hook-Switch Hanger

3. Install two screws into a wall. The screw heads must be remained about 3 mm (0.12").

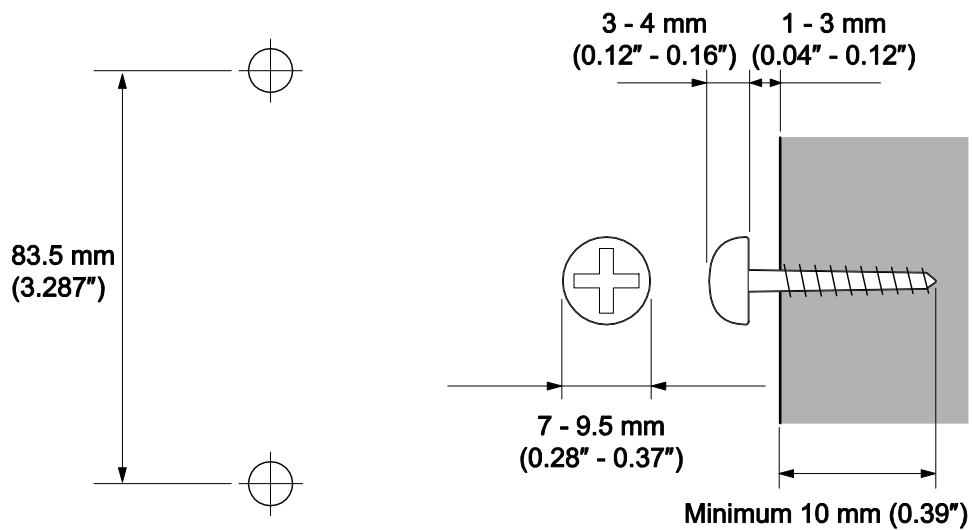

Figure 2-104 Wall-Mount Screw Guide

4. Mount the telephone on the wall.

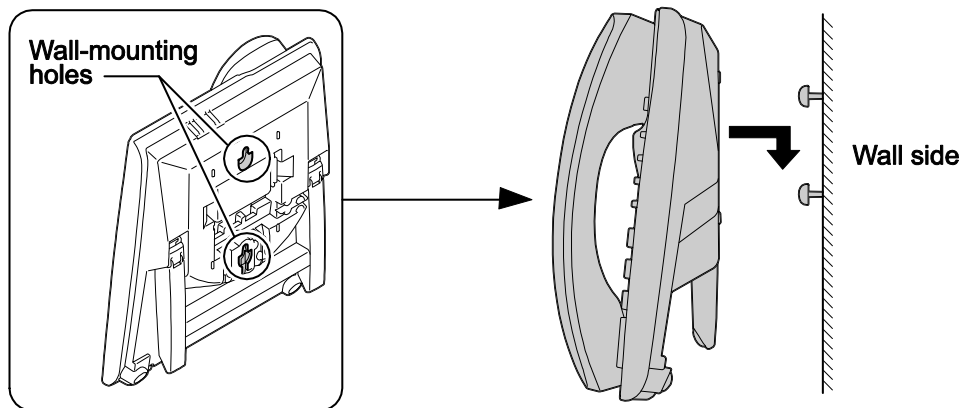

Figure 2-105 Mounting the Multiline Telephone

5.2 Install the IP Multiline Telephone (IP4WW-24TIXH-C1 TEL)

5.2.1 System Connection

The IP Multiline Telephone is connected via HUB.

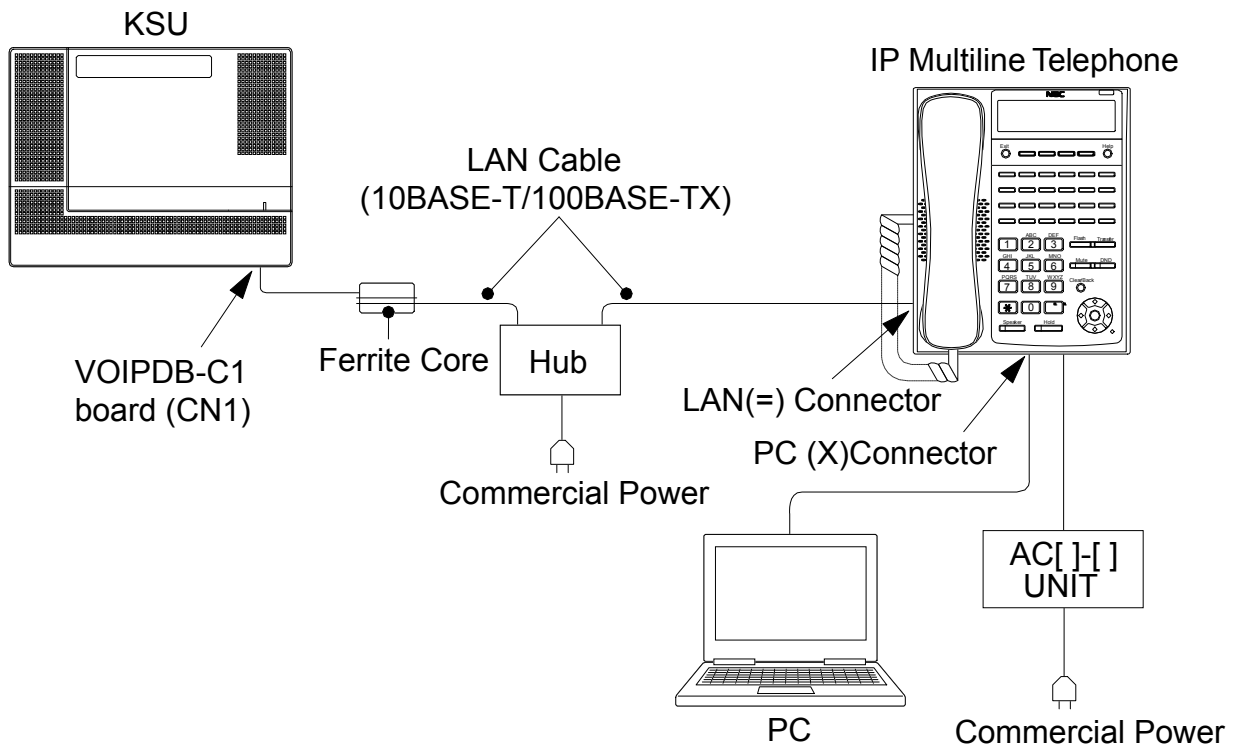

Figure 2-106 IP Multiline Telephone Connection

5.2.2 Installing the IP Multiline Telephone

1. Connect the LAN Network 10Base-T/100Base-TX cable to the **LAN(=)** connector.
2. If the Power feeding is used by AC []-[] UNIT, plug the AC []-[] UNIT cable to the DC input jack on the IP Multiline Telephone Base.
3. The IP Multiline Telephone has a Switching HUB to connect a PC to the LAN Network. Connect the 10Base-T/100Base-TX straight cable used for connection to the PC to the **PC(X)** connector and to the PC.

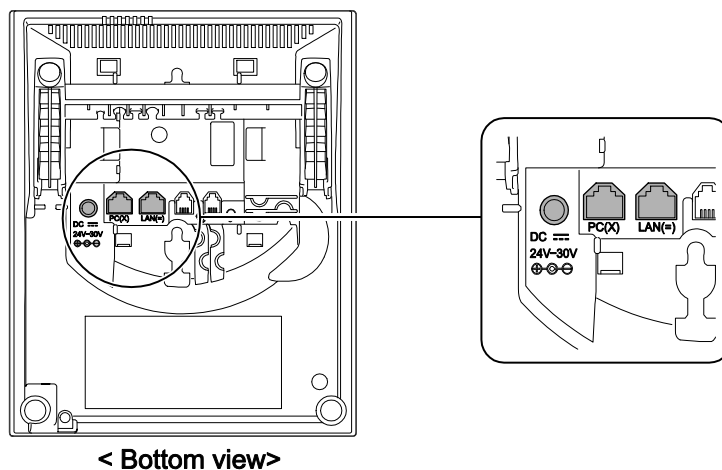

Figure 2-107 IP Multiline Telephone Connectors

5.2.3 Applying Power to the IP Multiline Telephone

IP Multiline Telephone (IP4WW-24TIXH-C1) supports two different power sources for the Telephone.

- ACA-UA/ AC-LE UNIT
Plug the Optional AC []-[] AC adapter input jack in the telephone base unit, and plug the 2-prong wall plug of the AC adapter in AC outlet.

- PoE(IEEE802.3af)
PoE (Power Over Ethernet) is a LAN technology that allows standard 10Base-T/100Base-TX data cables to pass electrical current from a power source to a requesting end device.

5.3 Installing the DSS Console

The 60D DSS-B Console can be installed on any digital extension port of 084M-B1/080E-B1 card directly. The pair extension for the DSS Console is assigned using system programming.

5.3.1 DSS Console Leg Adjustment

The DSS Console provides the leg for angling the console to best suit each user. The leg can be set for two different heights (Low/High).

5.3.1.1 Low Position Setting

1. Turn DSS Console over (button side down).
2. Adjust the legs to desired height.

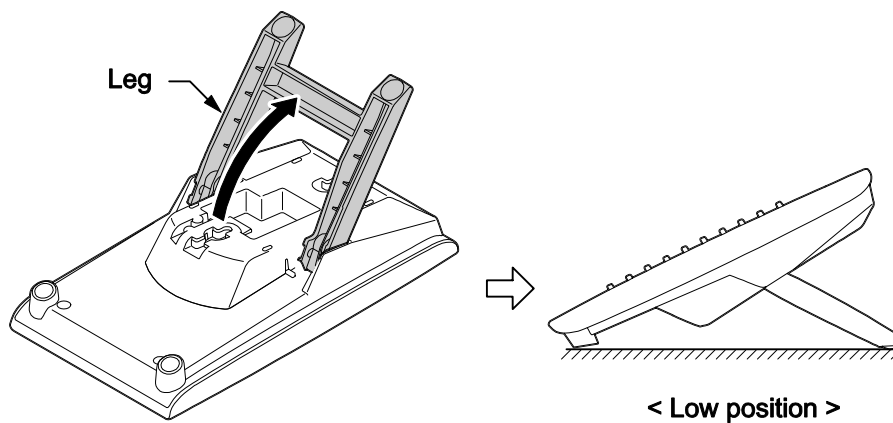

Figure 2-108 Low Position Setting

3. Lead the Line cord through the applicable grooves.

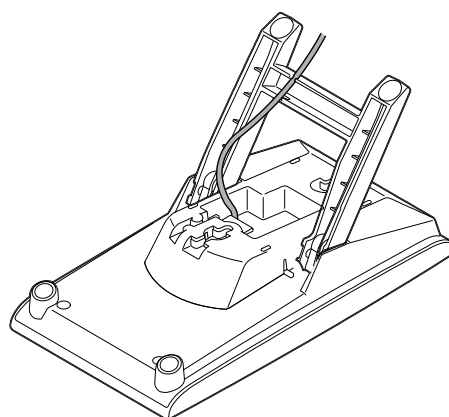

Figure 2-109 Cabling of DSS

5.3.1.2 High position setting

1. Turn DSS Console over (button side down).
2. Pull up the Leg Stoppers.

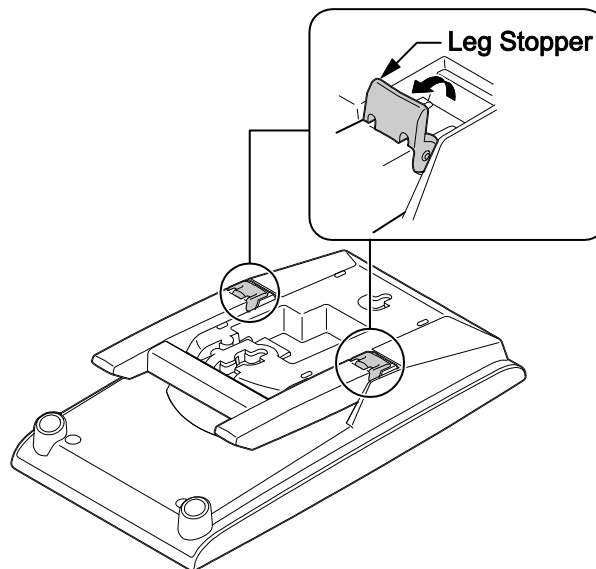

Figure 2-110 Leg Stopper of DSS Console

3. Adjust the leg to desired height.

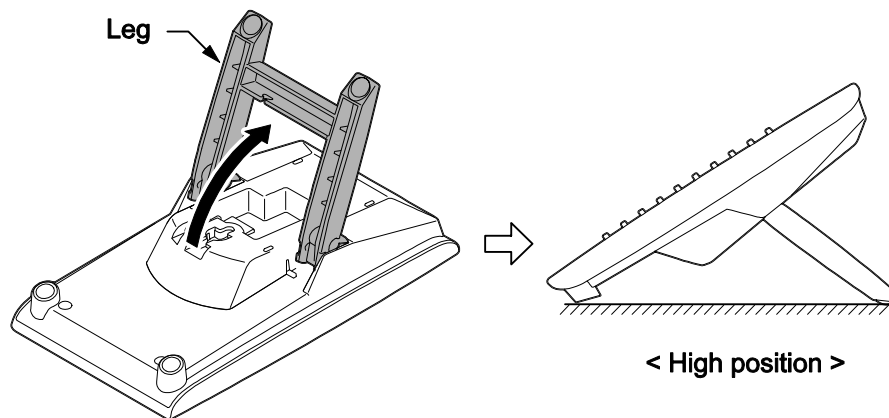

Figure 2-111 High Position Setting

4. Lead the Line cord through the applicable grooves.
(Refer to Cabling of DSS)

5.3.2 Wall-Mounting the DSS Console

1. Lift the leg and lead the cable through the applicable grooves. Refer to Cabling for Wall-Mount.
Lower leg to stowed position.

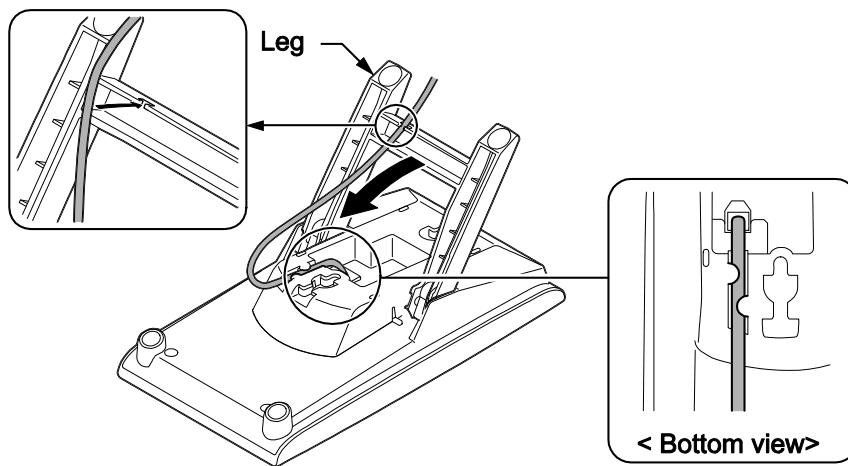

Figure 2-112 Cabling for Wall-Mount

2. Install two screws into a wall. The screw heads must be remained about 3 mm (0.12").

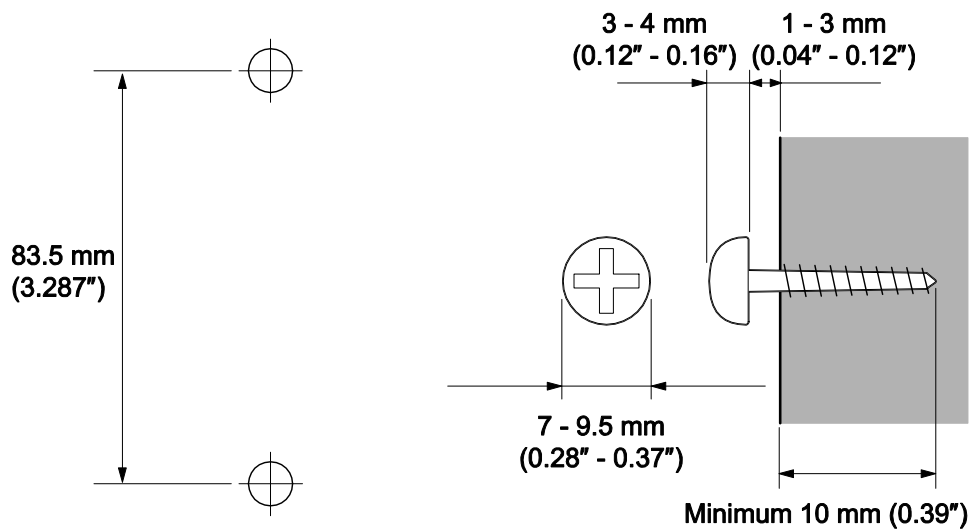

Figure 2-113 Wall-Mount Screw Guide

3. Mount the DSS Console to the wall.

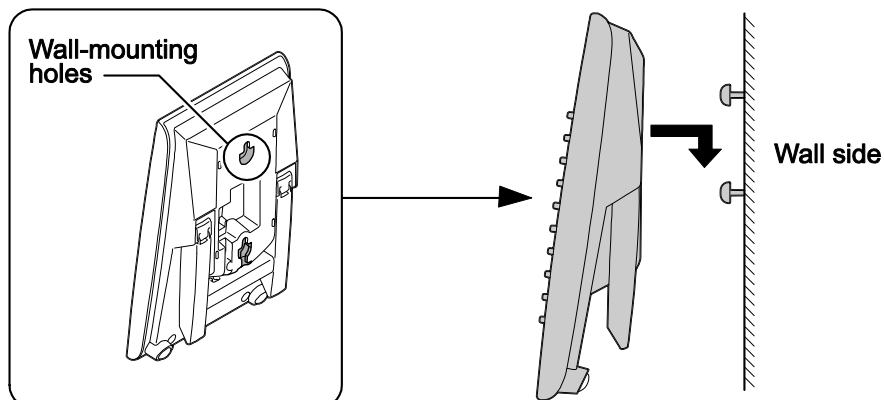

Figure 2-114 Mounting the DSS

5.4 Installing the Headset

The Multiline Telephone user can utilize a customer-provided headset in place of the handset. Like using Handsfree, using the headset frees up the user's hands for other work. However, Headset

Operation provides privacy not available from Handsfree.

1. Connect the Headset cord into the Headset socket.

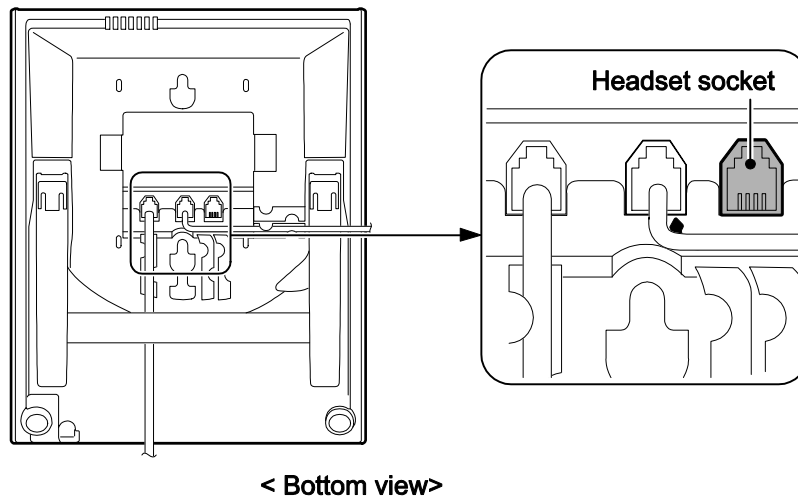

Figure 2-115 Headset Socket (2-wire Multiline Telephone)

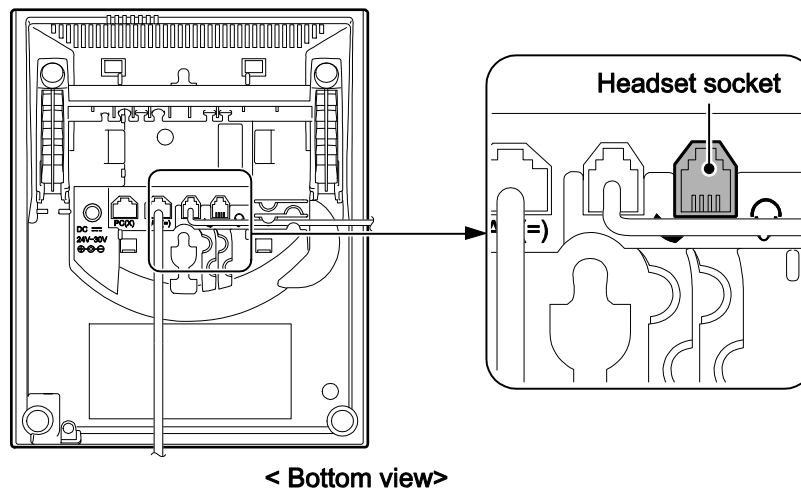

Figure 2-116 Headset Socket (IP Multiline Telephone)



The headset configuration is assigned using system programming.

5.5 Installing the Doorphone Box

5.5.1 Wall-Mounting the Doorphone

1. Remove the screw on the front of the Doorphone Box.
2. Remove the Wall-Mount bracket from the Doorphone Box.
3. Connect the cable to the screw terminals on the Doorphone box. (No polarity sensitive)

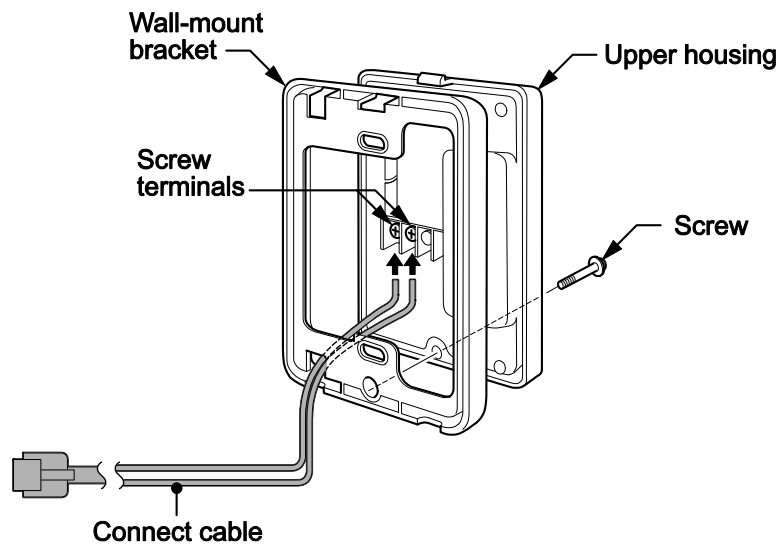

Figure 2-117 Doorphone Box and Bracket

4. Mount the Wall-Mount bracket on the wall using supplied screws.
5. Replace the Upper housing and tighten the screw.

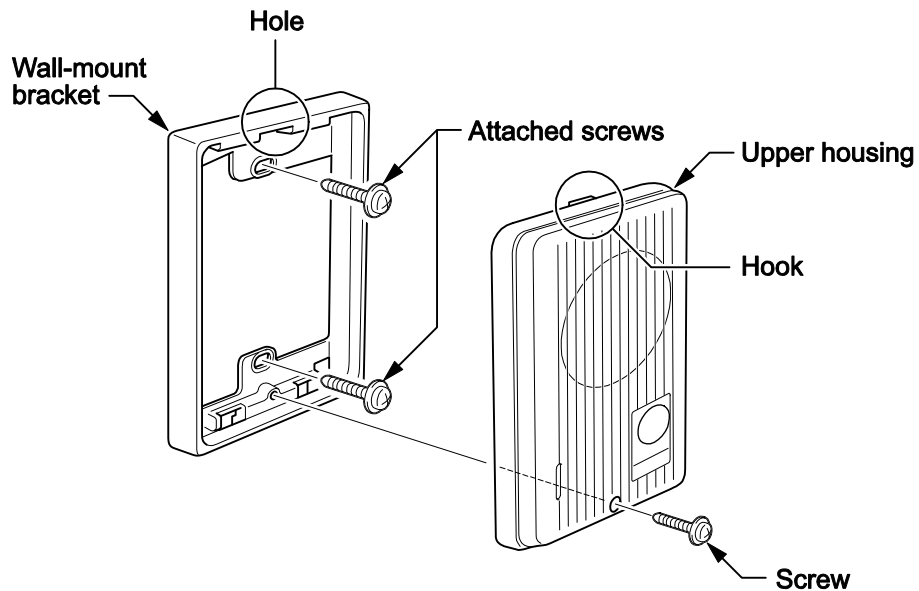

Figure 2-118 Doorphone

5.5.2 Connecting the Doorphone

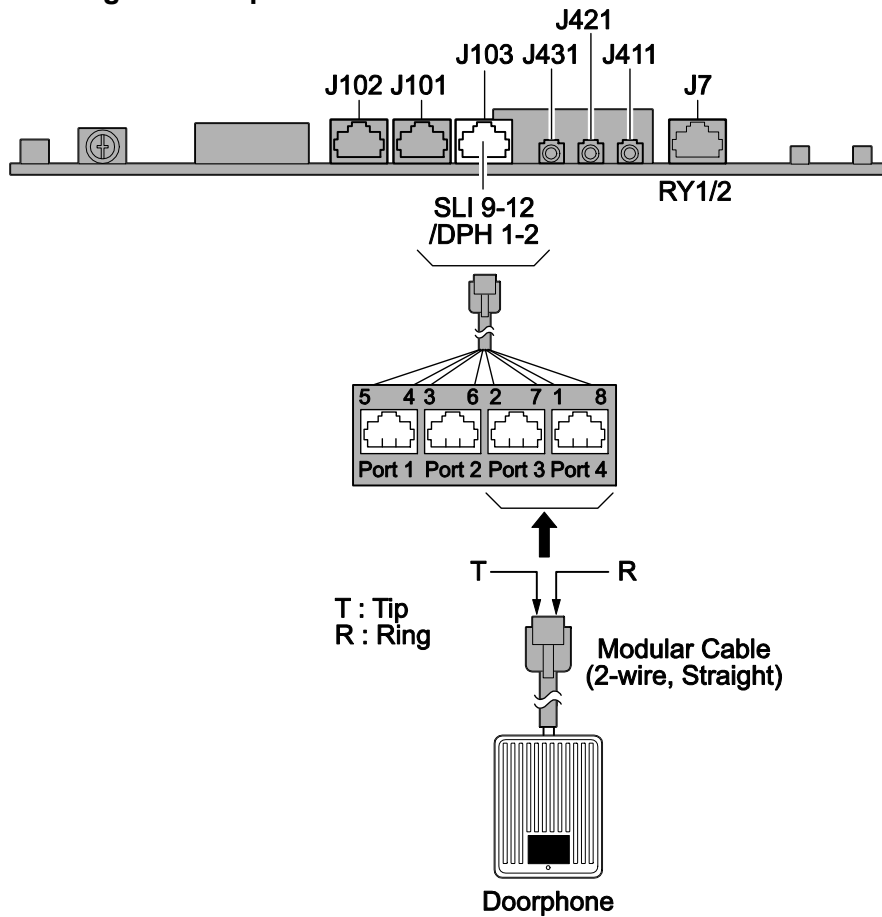

Figure 2-119 Connecting the Doorphone



The Doorphone configuration is assigned using system programming.



The 3rd party Doorphone Boxes cannot be connected to the port.

5.5.3 Doorphone Interface Specifications

Table 2-23 Doorphone Interface Specifications

Item	Specification
Output Impedance	600 Ω
Output Level	Nominal 250 mV (-10 dBm)
Maximum Output	400 mV RMS

5.6 Installing the Door Unlock Devices

A maximum of two door unlock devices can be connected to the KSU.

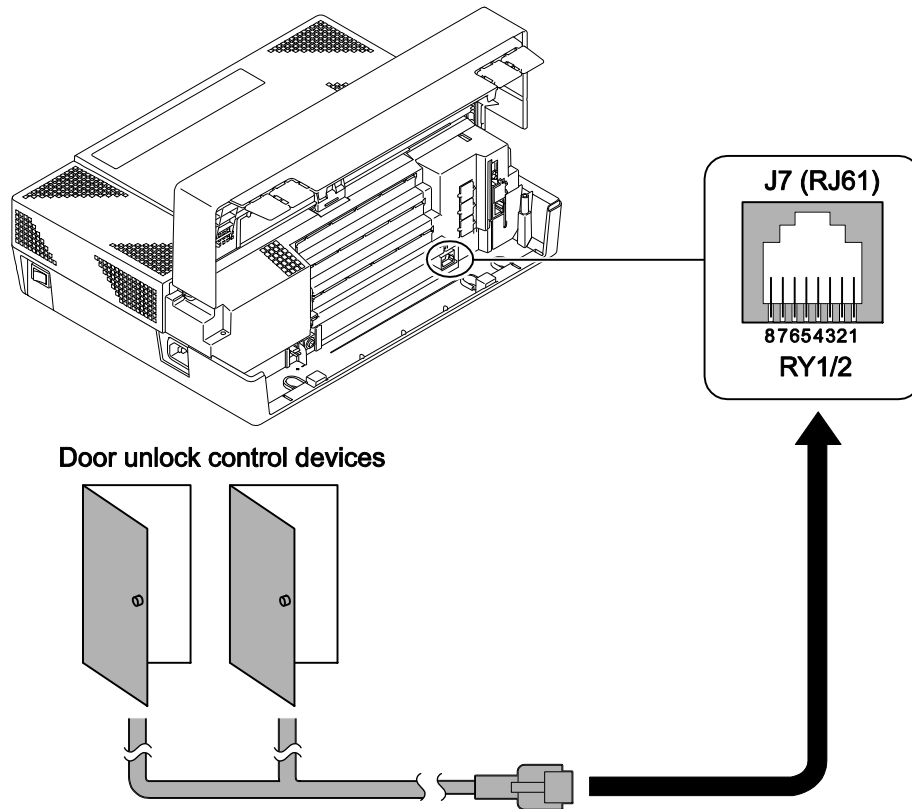

Figure 2-120 Connecting the Door Unlock Device

The following table shows the pin-outs for the RJ-61 cable connector.

Table 2-24 RJ-61 General Purpose/Door Unlock Relay Control Connector (J7)

	Pin No.	Connection
 <p>87654321 RY1/2 (J7)</p>	1	-
	2	-
	3	Relay 2
	4	Relay 1
	5	Relay 1
	6	Relay 2
	7	-
	8	-

Table 2-25 General Purpose/Door Unlock Relay Specifications

Item	Specification
Rated Voltage	DC 48 V Maximum
Rated Current	DC 320 mA Maximum
Contact	Normally Open

5.7 Installing the External Paging Speaker/External MOH/BGM Sources

5.7.1 Connecting the Audio Equipment

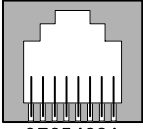

The audio jack labeled PAGE, MOH, BGM can be used for audio port (External paging, External MOH, BGM)



Audio port configuration is assigned using system programming.

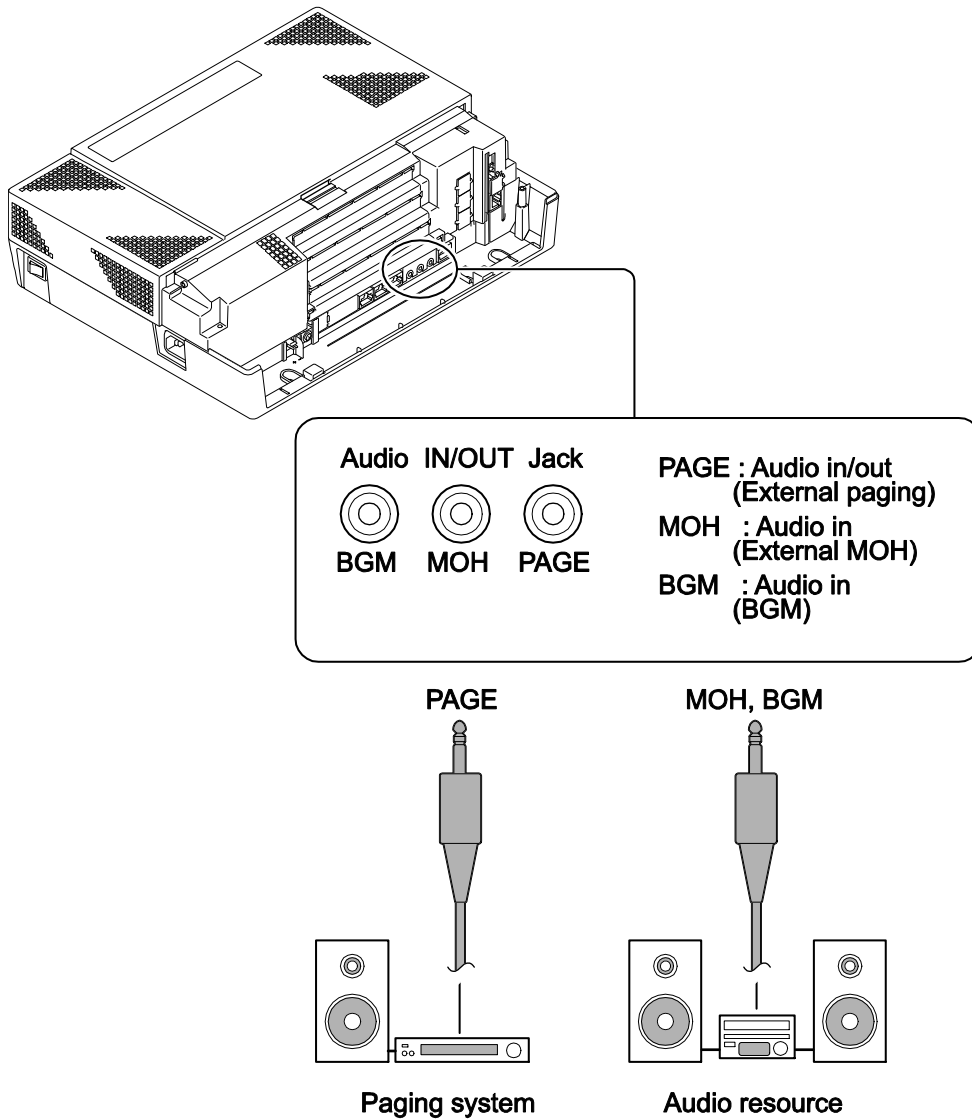

Figure 2-121 Connecting Audio Equipment

5.7.2 External Paging Output Specifications

Table 2-26 External Paging Output Specifications

Item	Specification
Output Impedance	600 Ω @ 1kHz
Output Level	Nominal 250 mV (-10 dBm)
Maximum Output	400 mV RMS

5.7.3 BGM/External MOH Source Input Specifications

Table 2-27 BGM/External MOH Source Input Specifications

Item	Specification
Input Impedance	600 Ω @ 1 kHz
Input Level	Nominal 250 mV (-10 dBm)
Maximum Input	1 V RMS

5.8 SMDR (Station Message Detail Recording)

5.8.1 General

SMDR (Station Message Detail Recording) provides a record of the system's outside calls. Typically, the record outputs to a customer-provided SMDR device such as PC via LAN port (J3) on the CPU card.

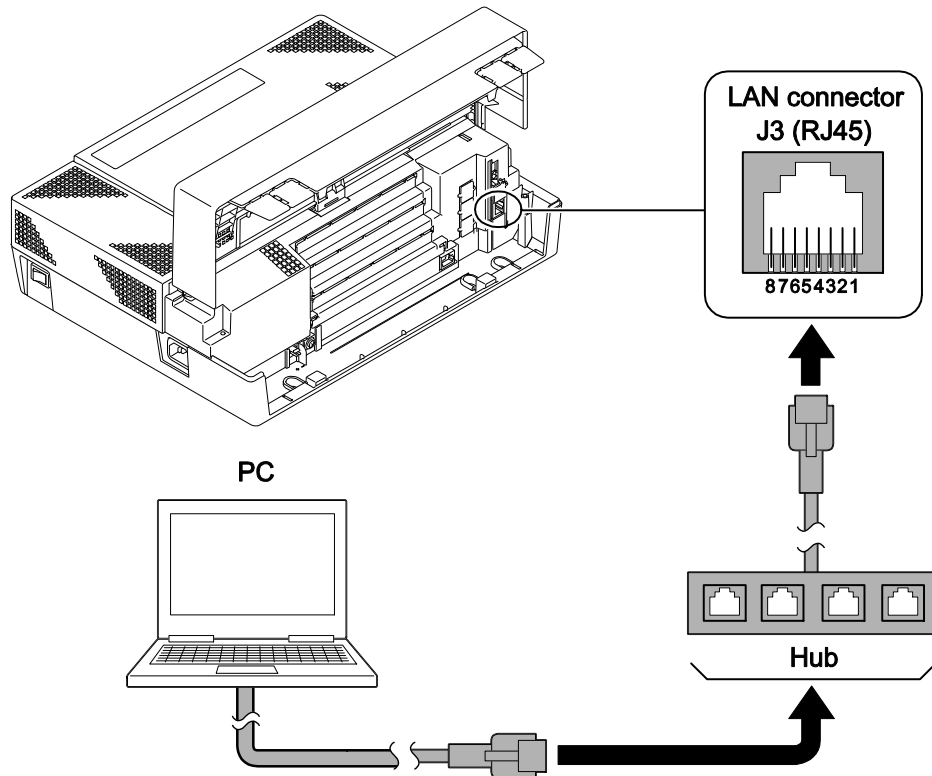

Figure 2-122 Connecting a PC for SMDR

1. Connect the straight type Ethernet cable (CAT5) between the system and In-house LAN.



The SMDR feature is assigned using system programming.

System Start Up

SECTION 1 SYSTEM START UP

1.1 Before Starting Up the System

Before starting up the system, make sure:

- KSU is installed correctly.
- All extensions are cabled correctly.
- Earth ground and PSTN Trunks are cabled correctly.
- All PCBs are configured, equipped, and secured correctly.
- AC power cord is cabled correctly.
- At least one display type Multiline Telephone is connected to the system. (for Programming)
- Pull out the Lithium battery protection sheet, before starting up the system.

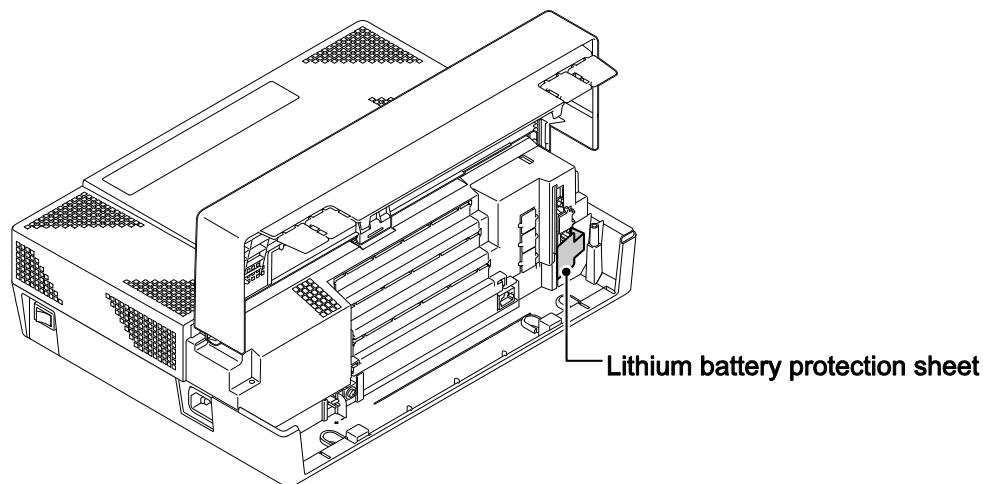

Figure 3-1 Lithium Battery Protection Sheet

1.2 Starting Up the System

There are two methods for startup (COLD Start and HOT Start).

Table 3-1 Start Up Method

Start Up Method	Description	Purpose
COLD Start	The factory setting data is loaded.	<ul style="list-style-type: none"> • First time start up • System Initialization
HOT Start	The customer setting data is loaded.	<ul style="list-style-type: none"> • System Reboot

1.2.1 Perform a Cold Start

This section describes the process for starting the system for the first time or starting a system that requires the customer data be deleted.



System software is loaded from flash memory, and the customer data is deleted from RAM memory.

To perform a Cold Start;

1. Set the power switch to off position.

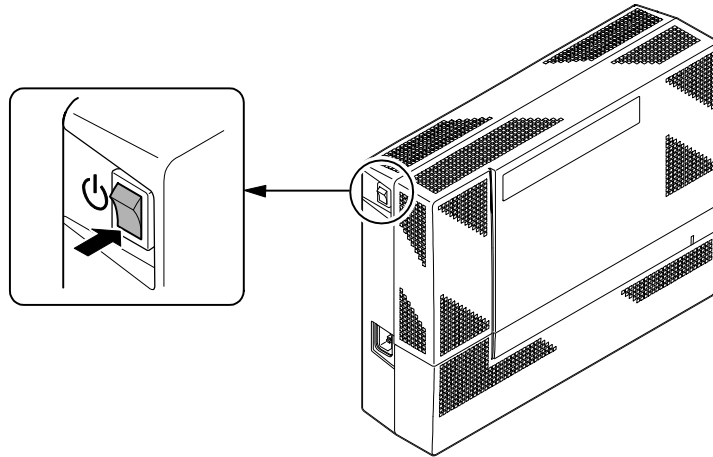

Figure 3-2 Power Switch Location

2. Open the Sub-Cover on the Main KSU and identify the **LOAD** button (S1) location on the CPU card.

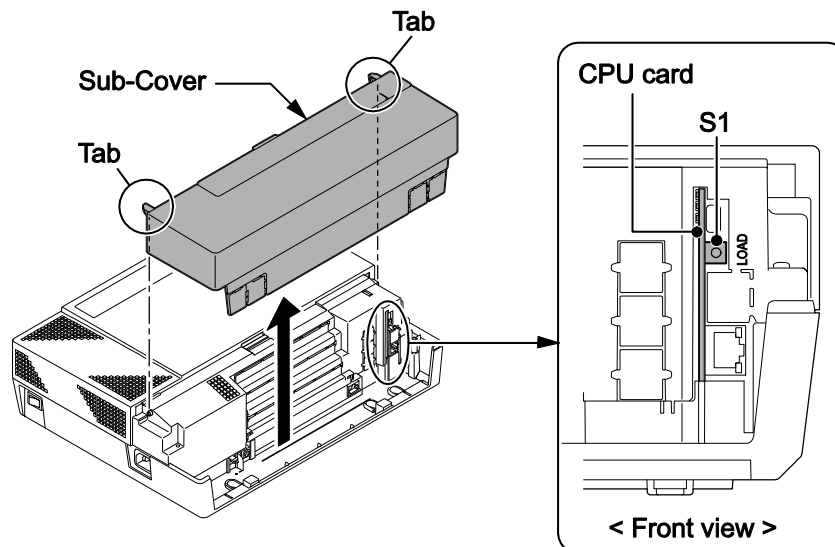

Figure 3-3 Load Button (S1) Location

3. Once the system has powered off, push in and hold the **LOAD** button (S1).
4. Turn the power switch ON at the Main KSU.
5. Continue holding the **LOAD** button (S1) for approximately three seconds or until Status LED (D5) starts flashing red.

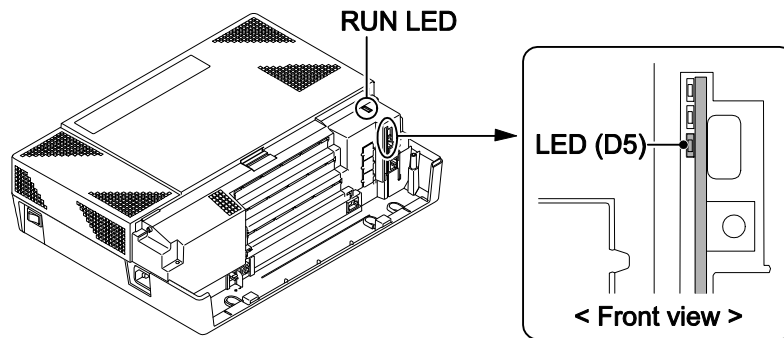

Figure 3-4 Status LED (D5) and RUN LED Location

6. Release the **LOAD** button.
7. When the system has completed reloading the software (about two minutes), the RUN LED is flashing blue on the CPU card and the connected Multiline Telephone's display will show the Time & Date and Extension Number.

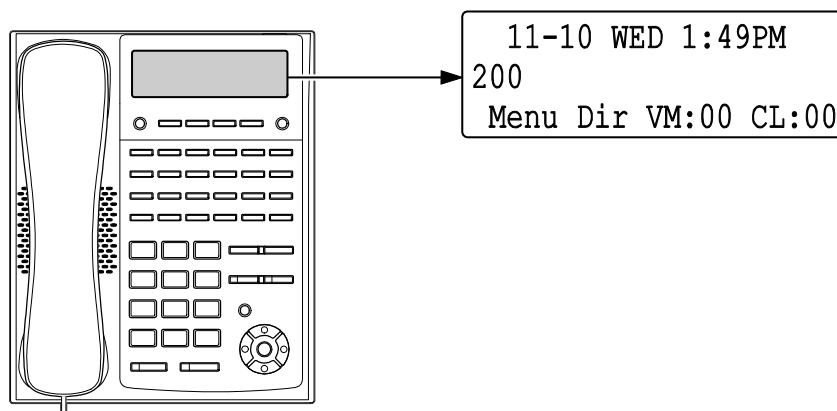

Figure 3-5 Display Indication (Idle)

1.2.2 Perform a Hot Start

This section describes how to load system software from flash memory, and the customer data from RAM memory.



System software is loaded from flash memory, and the customer data is loaded from RAM memory.

To perform a Hot Start;

1. Turn the system power off.
2. After it has powered off, turn the power switch back to ON. Wait approximately two minutes.
3. When the system has completed reloading the software, the RUN LED is flashing blue on the CPU card, and the connected Multiline Telephone's display will show the Time & Date and Extension Number as Display Indication (Idle).

SECTION 2 PROGRAMMING MODE

2.1 Entering the Programming Mode

The installer/system administrator can enter to the system programming mode from the Display Type Multiline Telephone. (A maximum of two users can enter mode at the same time)



In a newly installed system, use extension port 1.

1. Press **Speaker** key. (Do not lift the handset)
2. Dial # * # *.

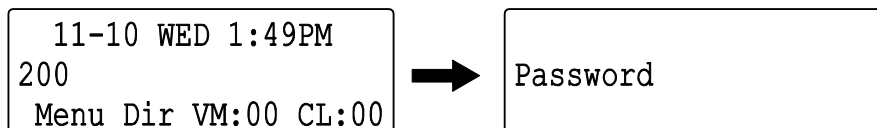

Figure 3-6 Entering Programming Mode Display 1

3. Dial the system password, then press **Hold** key to enter the Program Mode.

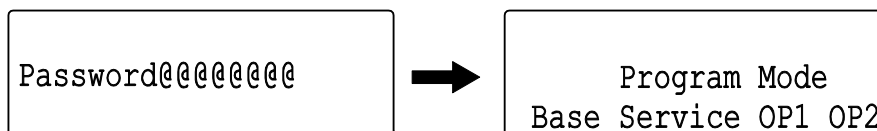

Figure 3-7 Entering Programming Mode Display 2



For the details of programming, refer to the SL1100 Programming Manual. (separate issue)

2.2 Exiting the Programming Mode

1. Press **Mute** key several times to return to the "Program Mode" Screen.

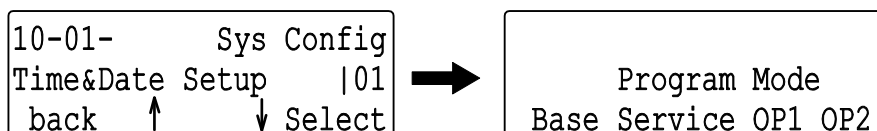

Figure 3-8 Exiting the Programming Mode Display 1

2. Press **Speaker** key to exit.

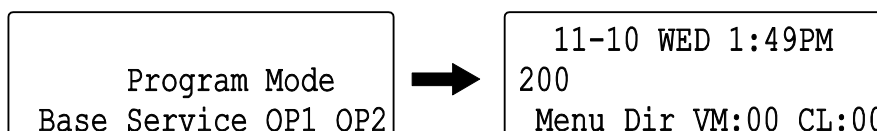

Figure 3-9 Exiting Programming Mode Display 2



The system automatically saves the customer data to the memory which is backed up by lithium battery.

2.3 Saving (Backup) the Customer Data

When the installer/system administrator exits from the programming mode, the system will automatically save the customer data to the on-board memory which is backed up by lithium battery. Additionally, the customer data can be saved to a CF Card for backup purpose. The PZ-VM21 daughter board must be installed to the CPU card with a **BLANK** CF card inserted.



For the details of PZ-VM21 daughter board installation, refer to Installing the PZ-VM21 PCB.

1. Turn the system power off, insert the blank CF card (32 MB or larger) to the CF slot on PZ-VM21.

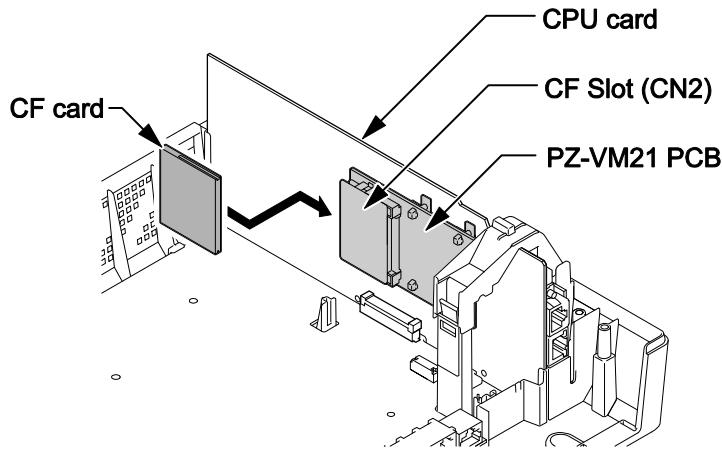

Figure 3-10 Inserting the CF card

2. Turn the power on, enter the Program Mode then PRG90-03.

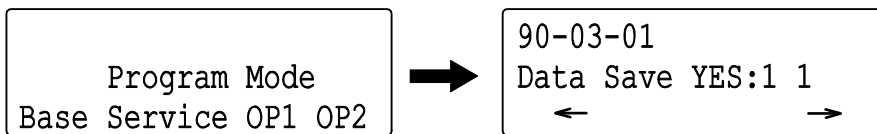

Figure 3-11 PRG90-03 Display

3. Dial 1 and press **Hold** key.
4. When the data backup to the CF card is completed, the display will be changed to the next PRG.

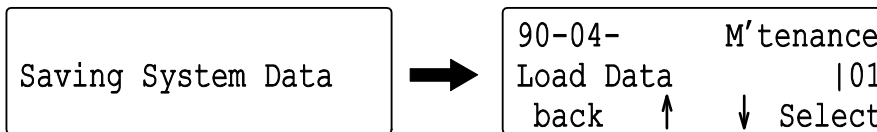

Figure 3-12 PRG90-04 Display

5. Remove the CF Card and exit from the Programming Mode.



The saved data on CF Card cannot be edited by the PC.

2.4 Loading the Customer Data

The backed up customer data can be loaded to the system by CF Card. The PZ-VM21 daughter board must be installed to the CPU card with a CF card inserted that the saved customer data loaded.



For the details of PZ-VM21 daughter board installation, refer to *Installing the PZ-VM21 PCB*.

1. Turn the power off, insert the Customer Data CF card into the CF Slot on PZ-VM21.

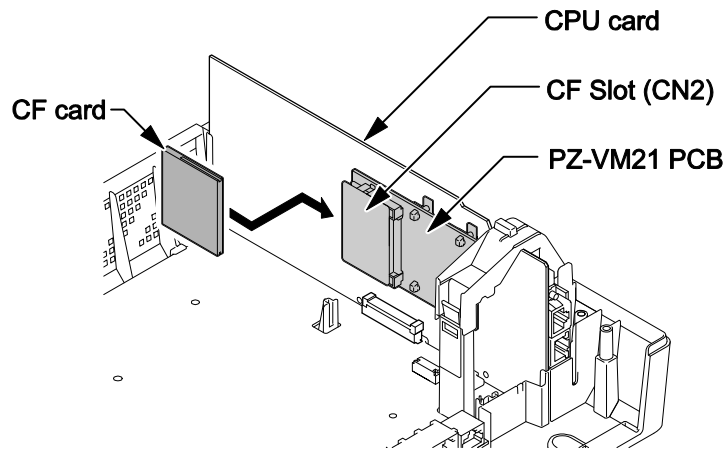

Figure 3-13 Inserting the CF card

2. Turn the power on, enter the Program Mode then PRG90-04.

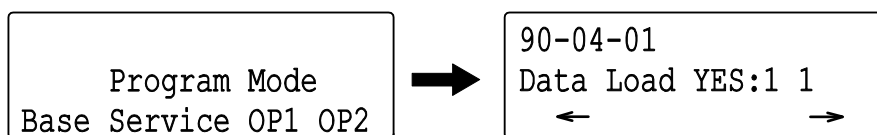

Figure 3-14 PRG90-04 Display

3. Dial **1** and press **Hold** key.
4. When the data backup to the CF card is completed, the display changes to the next PRG.

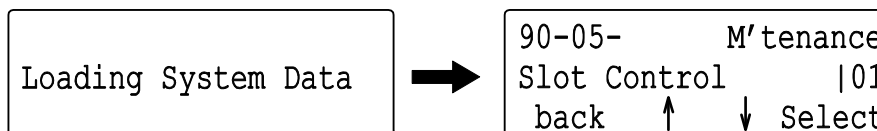

Figure 3-15 Next PRG Display

5. Remove the CF card and exit from the Program Mode.

SECTION 3 SYSTEM SHUT DOWN

3.1 Powering Off the System

1. Turn the KSU power off using the power switch.

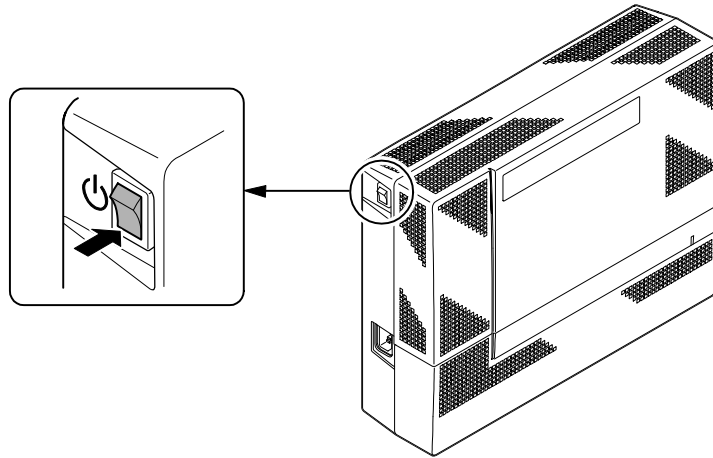

Figure 3-16 Power Switch Location

! *DO NOT power off by disconnecting the AC (or DC for battery backup) power. Always use the Power Switch on the Main KSU.*

! *All calls in progress will be cut off when the system is powered off, and if the Power Failure is set, the applicable extension will become operational.*

! *All user's setting (such as Call Forward, Camp-On, etc) will be kept.*

3.2 Resetting the System

The system reset is carried out using the "Power OFF and ON" operation.

MEMO

Maintenance

SECTION 1 FUSE REPLACEMENT

1.1 Replacing the Fuse



This fuse is only for external battery box connection, it is not used for AC power to the system.

1. Turn off the system power and disconnect AC cord.
2. Open and remove the Sub-Cover.

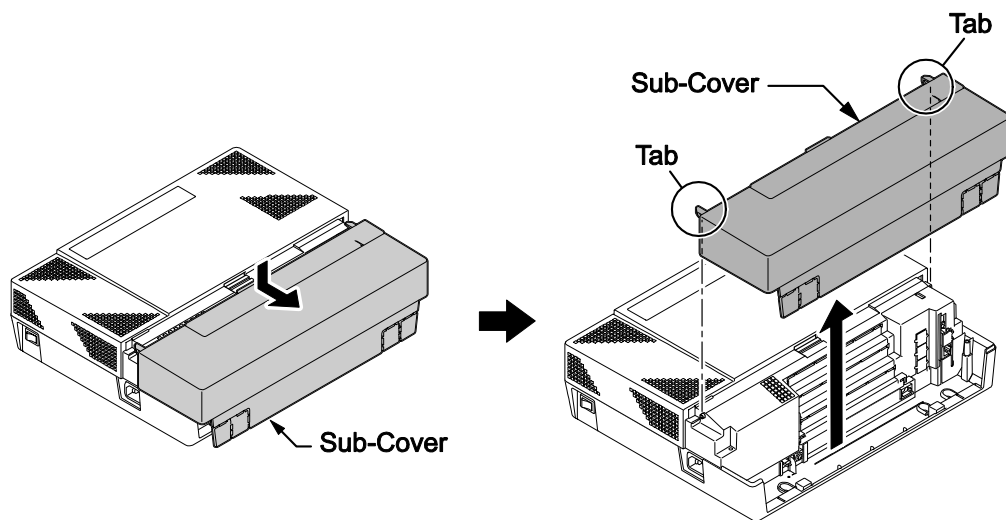

Figure 4-1 Removing the Sub-Cover

3. Loosen two screws and remove the Main-Cover.

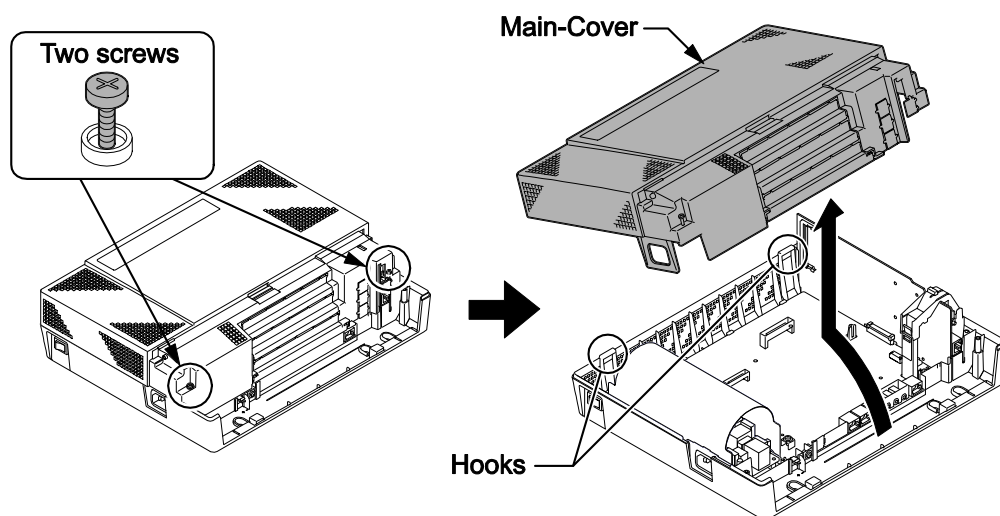

Figure 4-2 Removing the Main-Cover

4. Exchange the fuse (250 V/8 A) on 084M-B1 PCB.

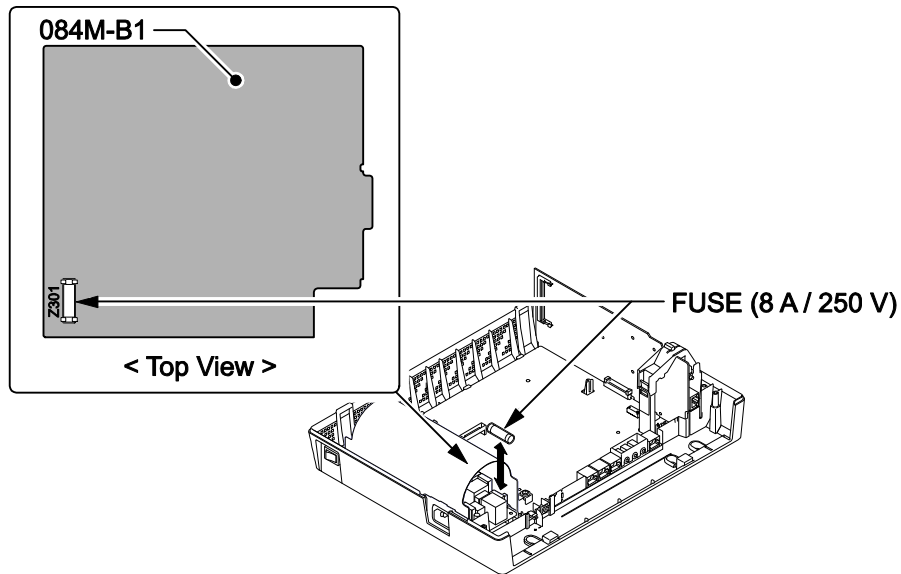

Figure 4-3 Exchanging the Fuse

5. Replace the Main-Cover and fasten two screws.

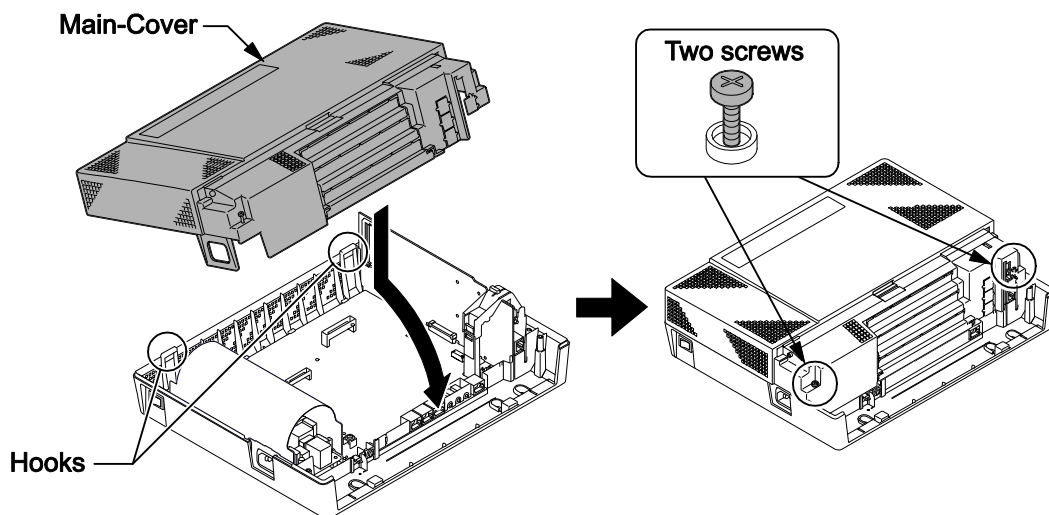

Figure 4-4 Replacing the Main-Cover

SECTION 2 LITHIUM BATTERY REPLACEMENT

2.1 General

The Lithium Battery (CR2032) is installed on the CPU Card in Main KSU. It provides the battery-backup of the RAM memory for approximately 36 months. When the battery power becomes low, the system will display a "Warning Message" to the assigned Display Multiline Telephone as below.

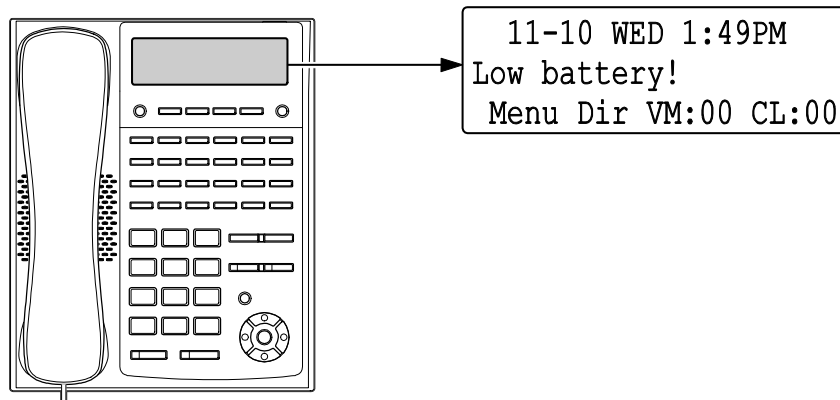

Figure 4-5 Warning of Low Battery

2.2 Lithium Battery Specification

Before replacing the Lithium battery, make sure which type of Lithium battery is required and prepare the new Lithium battery. (CR2032)



NEC recommends that a backup of the customer data is performed before powering off the system (either PCPro file or CF card backup) in order to replace the backup battery.



Risk of explosion if the battery is replaced by an incorrect type.



Dispose of used batteries as instructed by the manufacturer of the battery.

2.3 Replacing the Lithium Battery

1. Remove the Sub-Cover at the Main KSU.

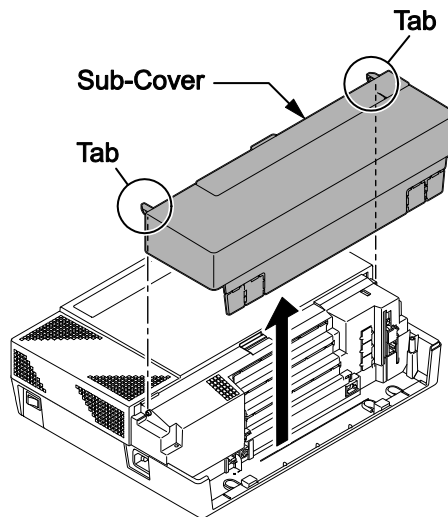

Figure 4-6 Removing the Sub-Cover

2. Power off the system, and remove the AC plug from the AC outlet.
3. Disconnect the AC power cord from the KSU.



AC power cord must be disconnected, otherwise the Main-Cover cannot be opened.

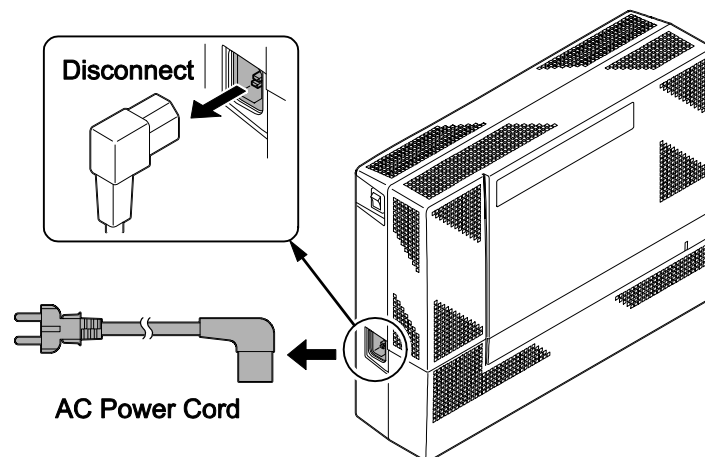

Figure 4-7 Disconnecting the AC Power Cord

4. Loosen two screws and remove the Main-Cover.

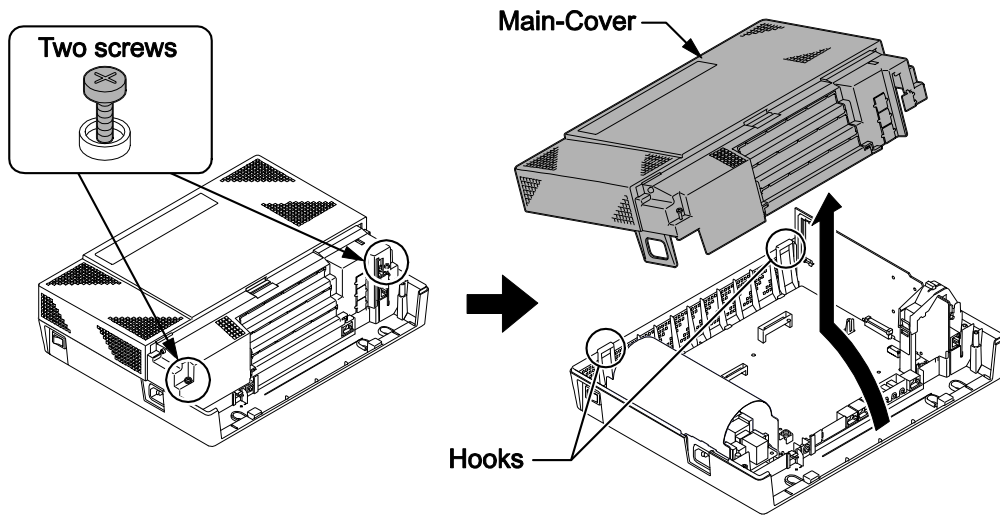

Figure 4-8 Removing the Main-Cover

5. Press tab A and lift the CPU support bracket.
6. Remove CPU card from the Main KSU.

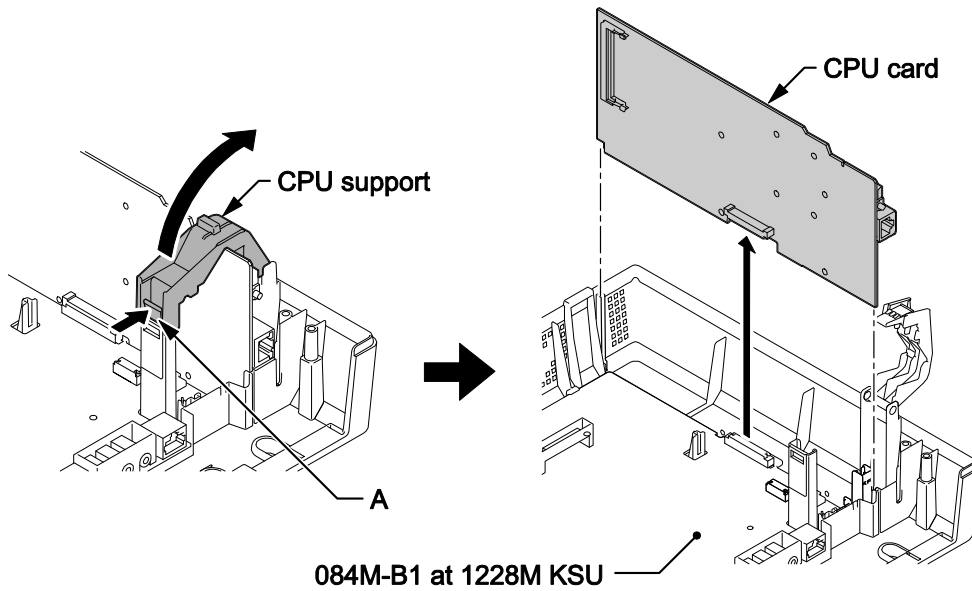

Figure 4-9 Removing the CPU Card

7. Refer to following figure for the Lithium battery location on the CPU card.

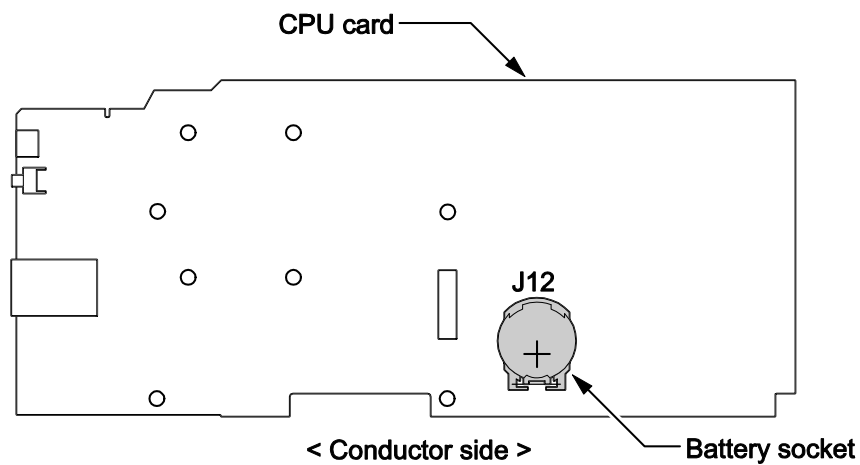

Figure 4-10 Location of Lithium Battery Socket

8. Remove the old Lithium battery and insert the new one into the socket.



The polarity “+” symbol must be on top as illustrated in following figure.

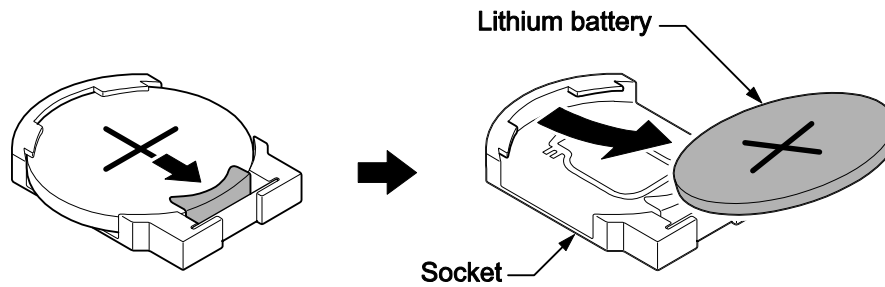

Figure 4-11 Removing the Lithium Battery

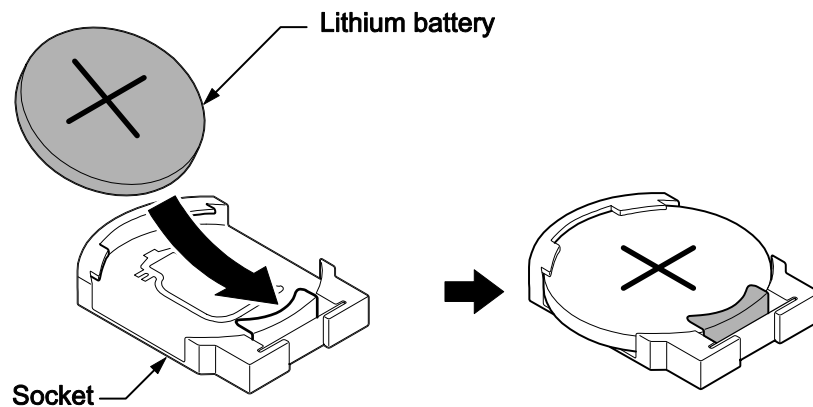

Figure 4-12 Inserting the Lithium Battery

9. Reinstall the CPU card into the 084M-B1 mother board and close the CPU support bracket.

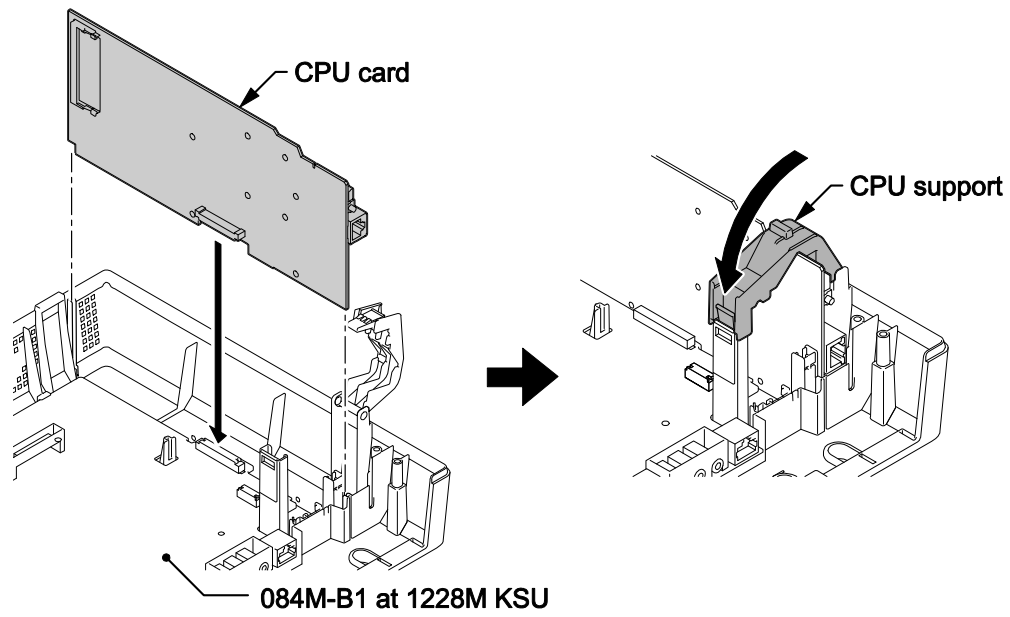

Figure 4-13 Installing the CPU Card

10. Replace the Main-Cover and Sub-Cover.

SECTION 3 MAIN SOFTWARE UPGRADING

3.1 General

The main system software is initially stored in the Flash memory located on the CPU card of the Main KSU. It can be upgraded by the new software on the CF (Compact Flash) card.

3.2 Before Upgrading the Main Software



NEC recommends that a backup of the customer data is performed before upgrading the main software (either PCPro file or CF card backup).

Before upgrading the main system software, the following preparations are necessary.

- Prepare the CF Card (32MB, or upwards and formatting by FAT(16)), and store the new main software on the CF card by PC. (New main system software is supplied by NEC.)
- Install the PZ-VM21 PCB. (if the system does not have it.)

3.3 Main Software Version Confirmation

The main system software version is confirmed by the following operation at the display type Multiline Telephone.



The following steps assume that program 15-02-60 is set to Advanced 1 or Advanced 2. If set to Standard the operation is as follows:

1. On-hook Condition.
2. Press Enter Key (Navigation Key).
3. Press "3" On Keypad to show the Main System Software version and Hardware Key Code.

1. On-hook Condition.

```
11-10 WED 1:49PM
200
Menu Dir VM:00 CL:00
```

Figure 4-14 Display of Multiline Telephone

2. Press Enter Key (Navigation Key).

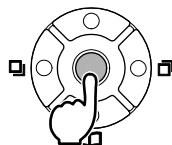

```
100:Operation List 1/8
>Call History: 00
Contacts
```

3. Dial **820**.

```
820:Properties      2/2
>System
Phone
```

4. Press Enter Key (**Navigation** Key) to show the main system software version and Hardware Key Code.

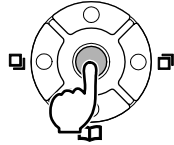

```
VERSION:          01.00
MAC: 00-60-B9-D8-DF-8E
HKEY: 2810-0000-0000
```

5. Off-Hook and return to Time & Date mode.

```
11-10 WED 1:49PM
200
Menu Dir VM:00 CL:00
```

3.4 Upgrading the Main Software

1. Power off the system and disconnect the AC cord from the KSU.
2. Remove the Sub-Cover.

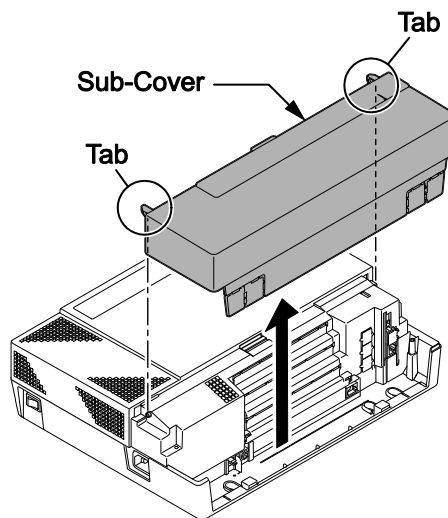

Figure 4-15 Removing the Sub-Cover

3. Loosen two screws and remove the Main-Cover.

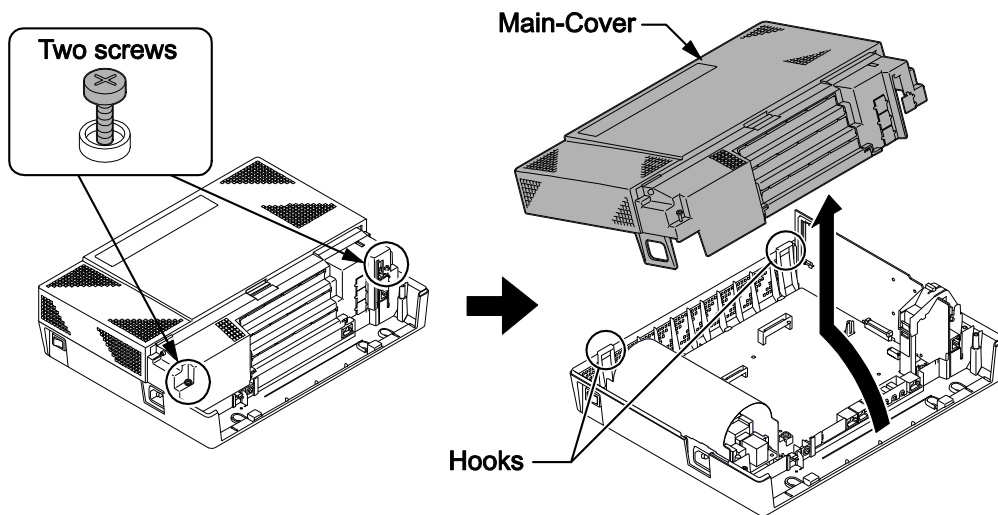

Figure 4-16 Removing the Main-Cover

4. Insert the CF card (with the new main system software loaded) to the CF slot on PZ-VM21 daughter board. (PZ-VM21 should be temporary installed if not already fitted.)

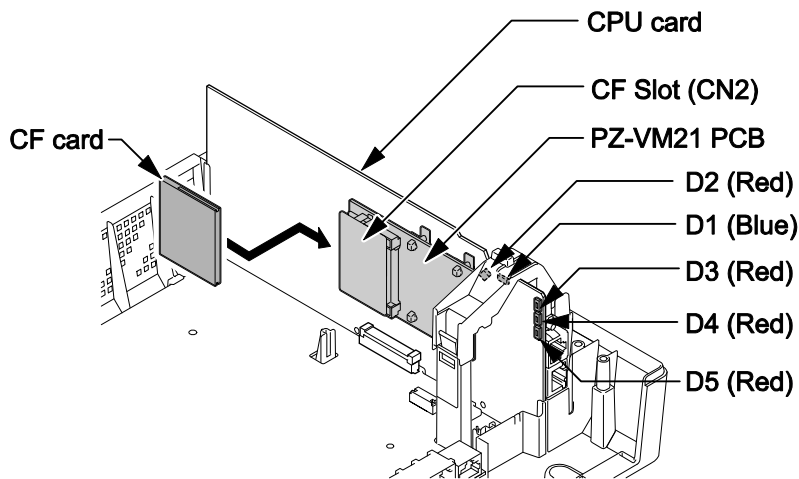

Figure 4-17 Inserting the CF card

5. Push in and hold the **LOAD** button (S1 on the CPU card).

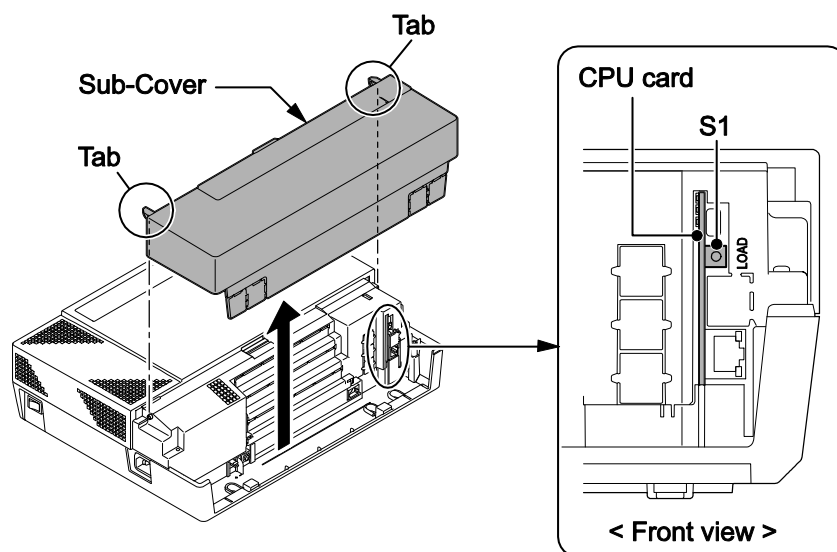

Figure 4-18 LOAD Button (S1) Location

6. Turn the system power on.
7. Continue holding the **LOAD** button (S1) for approximately 10 seconds or until Status LED (D5) starts flashing red.
8. Release the **LOAD** button (S1).
9. Wait until the Status LEDs (D2 to D5) on the CPU card has the following indications (approximately two minutes).

Table 4-1 Status LEDs

LED No.	Indication	Remarks
D2	Flashing Red	
D3	Flashing Red	
D4	Flashing Red	
D5	Off	

10. Turn the power off and remove the CF card from the CF slot on PZ-VM21.

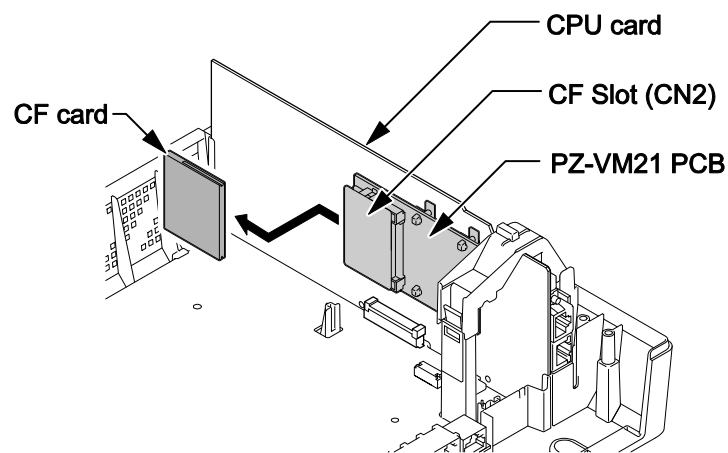

Figure 4-19 Removing the CF card

11. Replace the Main-Cover and Sub-Cover.
12. Turn the system power back on.
13. When the system has completed reloading the software, the RUN LED (D1) will flash blue.



To confirm the new software version number, press the Navigation key on any display telephone to view the system version number see Main Software Version Confirmation.



The existing system data in the flash memory is replaced, but the customer data (stored in the RAM) is saved.

SECTION 4 LED INDICATIONS

The LEDs on the CPU indicate the following:

- RUN (D1) = The CPU is operating (Blue)
- D2, and D3 = Alarms (Red)
- D4 = Flash access indication (Red)
- D5 = Boot status (Red)
- Refer to Program 90-10: System Alarm Setup for details on assigning alarm LEDs.

CPU LED Indications provides a list of each LED and associated operation and status indications. Refer to Inserting the CF card for the location of the LEDs on the CPU.

Table 4-2 CPU LED Indications

Status	LED Indication				
	RUN (D1)	D2	D3	D4	D5
System Operating Normally	Blinking	Off	Off	Off	Off
System Operate Normal + File accessing	Blinking	Off	Off	Access Blinking	Off
System Starting Up	On	Off	Off	Off	Off
Boot is starting	On	Off	Off	Off	Blinking
Initializing the disk or formatting	Blinking	Off	Off	Off	Off
Reading System Program	Blinking	Off	On	Access Blinking	Off
Reading Error of System Program	Off	On	Off	Off	Off
System Initializing + DSP loading process	On	Off	On	Access Blinking	Off
Initializing System Program	Blinking	Off	On	Access Blinking	Off
Upgrading System Program (in the Flash Memory)	Off	Blinking	Off	Access Blinking	Off
Batch file Error	Off	On	On	Off	Off
Completed the System Program Upgrade	Off	Blinking	Blinking	Blinking	Off
Security Tip Error	Off	Blinking	Off	Off	Off
Error alarm (Major) occurred	Blinking	Blinking	Off	Off	Off
Error alarm (Minor) occurred	Blinking	Blinking	Off	Off	Off
Shutting Down	Blinking	Off	Off	Off	Off
Power Off	Off	Off	Off	Off	Off

Specifications

SECTION 1 SYSTEM CAPACITY

Table 5-1 System Capacity

Items		1 KSU (1228)	Description	Note
Expansion Slot		2		
System Maximum Port		58	1KSU: 084M+PRI+080E+4COIDBx2	
Trunk Port Max.		38	1KSU: PRIx1+4COIDB/BR1x2	
Trunk Port	Analogue Trunks (COT)	12	1KSU: 4COIDBx3 on 084M/080E/008E/000E	
	BRI (T-Point)	12	1KSU: 2BR1x3 on 084M/080E/008E/000E	
	PRI (30B)	30	Max. one PRI/KSU	
	IP Trunk (SIP)	16	When MEMDB is Installed	
Station Port Max.		40	1KSU: 084M+080Ex2+BR1x3	
Station Port	2W Key Set	24	Max. 24/KSU 084M+080Ex2	
	SLT (-28V)	20	1KSU: 084M+008Ex2	
	BRI (S-Point)	12	1KSU: BR1x3 on 084M/080E/008E/000E	
	2W DSS Console	12	Connect to digital extension Port at 084M/080E	
	Doorphone	2	2DPH I/F on 084M (analogue extension port 3, 4) Alternative use with SLT	
	SIP-MLT/ SIP Std. terminal	16	When MEMDB is Installed	
	VM/VRS Channels	2 VM ports/ 4 VRS ports (default) (Total Max.8 w/o MEMDB or 16 w/MEMDB)	CFVMS-C1 Port increased by license.	
Virtual Extension		50		
Relay		2	2 circuits on 084M	
Power Failure Transfer		3	1 PFT circuit on 4COIDB (COI port 1 and PF port)	
External Paging (Audio Out)		1	1 audio-In/Out and 2 audio-In circuits on 084M.	
External MOH (Audio In)		1	Select one of 084M for MOH/BGM.	
External BGM (Audio In)		1		
Ethernet Port		1	1 circuit on CPU	
VoIP Channels		16	When MEMDB is Installed	
V.34 Modem		1	1 circuit on PZ-VM21	
Conference Circuits		32 (Max. 16 parties per Conference)		
DSP Resource ³		16	For 1228M KSU (DSP on CPU)	
		16	When PZ-VM21 is installed	
DSP Sender ⁴		128		

³ Service Tone receiver, DTMF receiver, Caller ID sender / receiver, MF receiver, MFC receiver

⁴ Service Tone sender, DTMF sender, MF sender, MFC sender

SECTION 2 SYSTEM SPECIFICATIONS

2.1 General Precautions

- Never attempt to insert wires, pins, etc. into the vents or other holes of the equipment.
- Do not use benzene, thinner, or the like, or any abrasive powder to clean the equipment. Wipe it with a soft cloth.

2.2 Environmental Requirements

Meeting established environmental standards maximizes the life of the system. Be sure that the site is not:

- In direct sunlight or in hot, cold or humid places.
- In dusty areas or in areas where sulfuric gases are produced.
- In places where shocks or vibrations are frequent or strong.
- In places where water or other fluids comes in contact with the equipment.
- In areas near high-frequency machines or electric welders.
- Near computers, telexes, microwaves, air conditioners, etc.
- Near radio antennas (including shortwave)

2.3 Operating Conditions

Table 5-2 Operating Conditions

Unit	Operating Conditions
KSU, PCBs and Multiline Telephones	Temperature: 0 to +40 degree C (32 to 104 degree F) Humidity: 10 to 90% (non-condensing)
Doorphone Box	Temperature: -20 to +60 degree C (-4 to 140 degree F) Humidity: 20 to 80% (non-condensing)

2.4 Site Requirements

A KSU can only be wall-mounted, it can only be floor-mounted if the optional External Backup Battery Box is installed.

2.5 AC Power Requirement

A dedicated 100V-120V/220V/230V/240V 50/60Hz circuit located within 2 meters of the KSU is required. A separate dedicated AC outlet is necessary for the KSU.



Double Pole/Neutral Fusing

(Power supply fuses are located at both the L and N side.)

Table 5-3 Power Requirement

	110VAC	120VAC	220VAC	230VAC	240VAC
Power Requirement	110 VAC@15 A	120 VAC@15 A	220 VAC@15 A	230 VAC@15 A	240 VAC@15 A
Power Consumption	Main KSU = 128 VA	Main KSU = 130VA	Main KSU = 154 VA	Main KSU = 154 VA	Main KSU = 156 VA
Input Voltage (Rated Voltage)	90 VAC to 264 VAC (100VAC/120VAC/220VAC/230VAC/240VAC)				
Frequency	47 Hz - 63 Hz (Rated Frequency: 50/60 Hz)				
Phase and Wire	Single Phase, 2 Line + PE Type				
Ground Requirement	No.14 AWG Copper Wire				
Feeding Voltage	SLT: 20 mA/-27 V				

	110VAC	120VAC	220VAC	230VAC	240VAC
AC Input I	Main KSU = 1.16 A	Main KSU = 1.08 A	Main KSU = 0.70 A	Main KSU = 0.67 A	Main KSU = 0.65 A
KWh	Main KSU = 0.128 KWh	Main KSU = 0.130 KWh	Main KSU = 0.154 KWh	Main KSU = 0.154 KWh	Main KSU = 0.156 KWh
BTU(KWh x 3413)	Main KSU = 437 BTU	Main KSU = 444 BTU	Main KSU = 526 BTU	Main KSU = 526 BTU	Main KSU = 532 BTU

2.6 Electrical Specifications <Power Supply> (KSU)

Table 5-4 Electrical Specifications of KSU

Item	Specification
Output Voltage	-27 V (81 W)
Related Voltage	-27 V
Load Fluctuation	-25.92 V to -28 V (-27.0 V ±4%)
Output Current	3.0 A
Ripple/Noise	200 mVp-p or less
Noise	-65 dBm or less
Over Voltage Protection	-31.2 V to -36.9 V
Over Current Protection	3.3 A to 3.9 A
Load Capacity	5000 µF

2.7 CPU

SL1100		
CONTROL SYSTEM		Digital
MPU	Manufacturer/ Name	Freescale Semiconductor PowerQUICC II Family MPC8248VRMIBA
	MPU Architecture	RISC (Reduced Instruction Set Computer), 32 Bit
	Core Frequency	262.144 MHz
PROGRAM STORAGE	Nor Flash	16 MB
DATA STORAGE	SDRAM	32 MB x 2
	SRAM	512 KB
SWITCHING (Time Division Matrix)		392 x 392 (Non-Blocking)

2.8 Traffic Capacity

Traffic Capacity	Basic System Package	Expanded System Package
Traffic Capacity	2540 BHCA	2540 BHCA



2540 Busy-Hour Call Attempts (BHCA) is based on a Full Capacity.

2.9 IP Terminal Power Chart

Table 5-5 IP Terminal Power Chart

IP Terminal	IEEE 802.3af Class	Label Indication (Maximum Current with All Options)			
		48 VDC		27 VDC	
IP4WW-24TIXH-C TEL	Class 2	130 mA	6.2 W	235 mA	6.3 W

2.10 IEEE802.af Class Specification

Table 5-6 IEEE802.af Class Specification

IEEE802.af	Minimum	Maximum
Class 2	3.84 W	6.49 W

2.11 Mechanical Specifications

Table 5-7 Mechanical Specifications

Equipment	Width	Depth	Height	Weight	Note
1228M-B KSU	375 mm (14.76 in)	115 mm (4.53 in)	290 mm (11.42 in)	Approx. 2 kg (70.55 oz)	
External Backup Battery	500 mm (19.69 in)	230 mm (90.55 in)	340 mm (13.39 in)	10.3 kg (excluding battery) (363.32 oz) 15.6 kg (including battery) (550.27 oz)	
Multiline Telephone	180 mm (7.09 in)	221 mm (8.70 in)	136 mm (5.35 in)	0.90 kg (31.75 oz)	
DSS Console	122 mm (4.80 in)	221 mm (8.70 in)	113 mm (4.45 in)	0.45 kg (15.87 oz)	
Doorphone	98 mm (3.89 in)	28.5 mm (1.12 in)	130 mm (5.12 in)	0.2 kg (7.05 oz)	

2.12 Optional Unit Mechanical Specifications

Table 5-8 Optional Unit Mechanical Specifications

Unit	Width	Depth	Height	Weight	Note
IP4[]-MEMDB-C1	67.5 mm (2.66 in)	32 mm (1.26 in)	2 mm (0.08 in)	0.01 kg (0.3 oz)	
IP4WW-VOIPDB-C1	66 mm (2.60 in)	138 mm (5.43 in)	18 mm (0.71 in)	0.05 kg (1.76 oz)	
PZ-VM21	53 mm (2.09 in)	85 mm (3.35 in)	13 mm (0.51 in)	0.03 kg (1.06 oz)	
IP4WW-080E-B1	160 mm (6.30 in)	198 mm (7.80 in)	32 mm (1.26 in)	0.17 kg (6.00 oz)	
IP4[]-008E-B1	160 mm (6.30 in)	198 mm (7.80 in)	32 mm (1.26 in)	0.16 kg (5.64 oz)	
IP4WW-000E-B1	160 mm (6.30 in)	198 mm (7.80 in)	32 mm (1.26 in)	0.12 kg (4.23 oz)	
IP4WW-4COIDB-B1	75 mm (2.95 in)	170 mm (6.69 in)	18 mm (0.71 in)	0.08 kg (2.82 oz)	
IP4WW-1PRIU-C1	160 mm (6.30 in)	198 mm (7.80 in)	32 mm (1.26 in)	0.15 kg (5.29 oz)	
IP4WW-2BRIDB-C1	122 mm (4.80 in)	168 mm (6.61 in)	25 mm (0.98 in)	0.09 kg (3.17 oz)	
IP4WW-CFVMS-C1	43 mm (1.69 in)	37 mm (1.46 in)	3.5 mm (0.14 in)	0.01 kg (0.35 oz)	

2.13 Doorphone Interface Specifications

Table 5-9 Doorphone Interface Specifications

Item	Specification
Output Impedance	600 Ω
Output Level	Nominal 250 mV (-10 dBm)
Maximum Output	400 mV RMS

2.14 General Purpose/Door Unlock Relay Specifications

Table 5-10 General Purpose/Door Unlock Relay Specifications

Item	Specification
Rated Voltage	DC 48 V Maximum
Rated Current	DC 320 mA Maximum
Contact	Normally Open

2.15 External Paging Output Specifications

Table 5-11 External Paging Output Specifications

Item	Specification
Output Impedance	600 Ω @ 1 kHz
Output Level	Nominal 250 mV (-10 dBm)
Maximum Output	400 mV RMS

2.16 BGM/ExMOH Source Input Specifications

Table 5-12 BGM/External MOH Source Input Specifications

Item	Specification
Output Impedance	600 Ω @ 1 kHz
Input Level	Nominal 250 mV (-10 dBm)
Maximum Input	1 V RMS

2.17 External Sensor Device Interface Specifications

Table 5-13 External Sensor Device Interface Specifications

Applied Voltage during Sensor Off	Loop Current during Sensor On	Port Assignment
24 V	40 mA	Program10-03-05: 0
5 V		Program10-03-05: 1

The External Sensor device configuration shall be assigned by system program and the programming is different with a Sensor Type.

2.18 CPU Card LAN Port Specifications

Table 5-14 CPU Card LAN Port Specifications

Item	Specification
Standard	IEEE802.3 10Base-T and 100Base-TX Compliant
Access	CSMA/CD
I/F (Layer 1)	Speed: 10 Mbps/100 Mbps Auto Negotiation Cable: CAT5 or better, Straight/Cross Auto Crossover

2.19 Cabling Requirements

- Do not run extension cable in parallel with the AC source, telex or computer etc. If the cables are near cable runs to those devices, use shielded cable with grounded shields or install the cable in conduit.
- When cables must be run on the floor, cable protectors must be used.
- Cable runs for Multiline Telephones, DSS Consoles, Single Line Telephones, and Doorphone Boxes must be a dedicated, isolated cable pair.
- Aerial distribution cabling is not allowed.
- Trunk Lines must be installed with lightning protectors.
- Do not use 4-wire cabling for SLT connections.

2.20 Cable Requirements

Table 5-15 Cable Requirements

Device	Cable Type	Cable Run Length
Multiline Telephone	24 AWG (Φ0.5 mm)	300 m (984.3 ft)
Multiline IP Telephone	CAT5 Straight Cable	100 m (328.1 ft)
DSS Console	24 AWG (Φ0.5 mm)	300 m (984.3 ft)
Single Line Telephone Analogue Terminals (20mA)	24 AWG (Φ0.5 mm)	1,125 m (3,691ft)
Doorphone Box	24 AWG (Φ0.5 mm)	150 m (492.1 ft)
CPU LAN Port to External Device	Ethernet Cross Cable	100 m (328.1 ft)
CPU LAN Port to Switching Hub	Ethernet Straight Cable	100 m (328.1 ft)
ISDN Terminal	4-wire, 24 AWG (Φ0.5 mm)	100 m (328.1 ft) (P-MP Short -passive) 300 m (984.3 ft) (P-MP Long -passive) 500 m (1,640.4 ft) (P-P)

MEMO

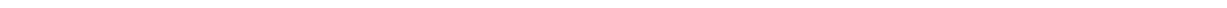

SL1100
Hardware Manual

NEC Corporation

ISSUE 1.0 (R2.0)